

INSTALLATION, OPERATION, AND MAINTENANCE MANUAL

Optima 72

Direct Vent Fireplace Heater



Models: 72-DVTE30P-2
72-DVTE30N-2
72-DVTE30P-2-ERG
72-DVTE30N-2-ERG

Serial Numbers 701261 and higher

WARNING: If the information in this manual is not followed exactly, fire or explosion may result causing property damage, personal injury or loss of life.

Do not store or use gasoline or other flammable vapors and liquids in the vicinity of this or any other appliance.

WHAT TO DO IF YOU SMELL GAS:

- * Do not try to light any appliance.
- * Do not touch any electrical switch; do not use any phone in your building.
- * Immediately call your gas supplier from a neighbor's phone. Follow the gas supplier's instructions.
- * If you cannot reach your gas supplier, call the fire department.

Installation and service must be performed by a qualified installer, service agency or the gas supplier.

For use with natural gas or propane
(Conversion kit required to change fuel)

INSTALLER:
LEAVE THIS MANUAL WITH THE
APPLIANCE.

CONSUMER:
RETAIN THIS MANUAL FOR FUTURE
REFERENCE.

Archgard Fireplace Products
300 Railway Avenue
Raymond, AB T0K 2S0
Canada

This appliance may be installed in an aftermarket permanently located, manufactured home (USA only) or mobile home where not prohibited by local codes.

This appliance is only for use with the type of gas indicated on the rating plate. This appliance is not convertible for use with other gases, unless a certified kit is used.

! DANGER



**HOT GLASS WILL
CAUSE BURNS.
DO NOT TOUCH GLASS
UNTIL COOLED.
NEVER ALLOW CHILDREN
TO TOUCH GLASS.**

A barrier designed to reduce the risk of burns from the hot viewing glass is provided with this appliance and must be installed for the protection of children and other at-risk individuals.



We recommend that our gas hearth products be installed and serviced by professionals who are certified in the U.S. by the National Fireplace Institute® (NFI) as NFI Gas Specialists.

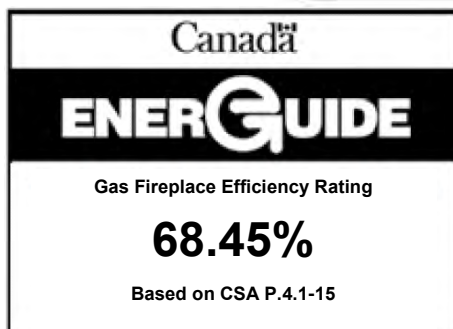

200-1917-16
April 06, 2026

TABLE OF CONTENTS

Caution and Safety Instructions	6
Appliance Certification, Installation Codes and Specifications, High Altitude Installation	7
Gas Connections	8
Appliance Dimensions and Clearance to Combustibles	9
Mantle Clearances	10
Heat Sensitive Flooring Materials	11
Framing Dimensions, Termination	12
Locating Gas Fireplace and Vent Termination Locations	13
Allowable Termination Locations	14
Approved Vent Components and Venting Connection	15
Venting	15-25
Electrical Connections (Fan System) and Wiring Diagram	26
Log Placement (Fiber Log Set)	27-31
Brick panel set installation	32-34
Eternal Flame Reflective Ceramic Glass panel set installation	35-36
First Fire and Lighting Instructions (CAUTION)	37
Final Installation Check and Initial Operation	38
Lighting Instructions on Rating Plate	39
Glass Door Removal and If your Glass Breaks	40
Louver (grill) instructions	41
Safety Barrier Installation	42
Eclipse Front	43-45
Dynamic Start Advantage	46
Remote Control Set-up and Operation	47-52
Maintenance and Cleaning the Appliance	53
Servicing Under Warranty & Adjusting Primary Air Shutter	54
Adjusting Primary Air Shutter (Continued) Changing Main Burner Orifice	55
Checking Inlet/Outlet gas pressures, Adjusting Pilot and Convertible Pilot Orifice	56
Replacing Convection Blower (Fan)	57
Valve Tray Assembly and Parts List	58
Log and Pan Burner Parts List	59
Replacement Parts List	60-61
Warranty	62
Frequently Asked Questions	63
Warranty Registration	64

INTRODUCTION

Congratulations on choosing an Archgard fireplace!

The Optima 72-DVTE30-2 is one of the most advanced direct vent fireplace heaters available. It is solidly designed using the latest technology and manufactured to the highest quality. It is our aim to provide you with an appliance for many trouble-free years of reliable service.

The following are just some of the many features of your new gas fireplace:

- **Heater Classification** The 72-DVTE30-2 is classified as a heating appliance. In conjunction with an optional thermostat, the Optima 72 can be operated continuously for zone heating.
- **High Efficiency** The 72-DVTE30-2 has one of the highest efficiencies of any fireplace, which means that it is less expensive to operate.
- **Adjustable Fan Speed** Heat circulation fan is fully adjustable. The fan can be adjusted through 6 speeds to suit your comfort level.
- **Adjustable Flame** The flame aesthetics and heat output can be adjusted to suit your heating needs.
- **Solid Construction** The 72-DVTE30-2 is constructed mainly of 14 and 18 gauge galvanized and aluminized steel for long life and durability.
- **Electronic Control System** This fireplace comes standard with the Dynamic Start Advantage. This new electronic ignition system is the latest in fireplace technology. It helps to create a better draft, better flame appearance, less condensation on the glass, and years of care-free operation. See Page 40 for complete explanation of how the system works.
- **Multiple Electronic Pilot Settings** This fireplace uses a gas control valve that is operated by a Multifunction Remote Control. It can be set up as either an Intermittent Pilot Ignition (IPI) system, or Continuous Pilot on Demand Ignition (CPI) system (also known as a Pilot on Demand (POD)).

Please read the manual carefully prior to installation and operation of the appliance. Proper installation, operation and maintenance of the appliance will provide you with many years of enjoyment.

Model Number Definition (72-DVTE30P-2 / 72-DVTE30N-2) (-ERG)

72	Number assigned to identify the fireplace
DV	Direct Vent
T	Top Vent
E	Electronic Ignition
30	Natural Gas Input Rating in BTU
N or P	Natural Gas or Propane
-2	Revision Number
-ERG	Includes Eclipse faceplate and Eternal Flame reflective ceramic glass panel set

CPI vs IPI:

Continuous Pilot on Demand Ignition (CPI): In this mode the pilot runs continuously even when the main burner is off. The Continuous Pilot on Demand Ignition operates on a seven day cycle. If the main burner is not turned on for seven continuous days, the pilot will turn itself off. When the main burner is lit again the cycle repeats. The pilot will remain lit for seven days, even after the main burner is turned off. If the main burner is lit during a seven day timing cycle, the seven day timer will reset.

Intermittent Pilot Ignition (IPI): A fuel saving mode in which the pilot is only used when the main burner is on. This appliance is shipped in IPI mode. IPI mode is often the preferred method, however, there are some situations where it may be preferable to switch the fireplace into CPI mode. For example, in colder climates the glass door or the front of the fireplace could become very cold to the touch. Dynamic Start Advantage will solve most problems experienced by older IPI operated fireplaces.

**Please complete and submit the warranty registration card included in the back of this manual or by visiting us at:
www.archgard.com/warranty-registration**

RATING PLATE SAMPLE



DO NOT REMOVE THIS LABEL

MODEL: 72-DVTE30P-2 (SIT 885 Proflame)
Manufactured as Propane.

LISTED VENTED GAS FIREPLACE HEATER and GAS-FIRED APPLIANCES FOR USE AT HIGH ALTITUDES. Tested to: ANSI Z21.88-2019 / CSA 2.33-2019, CAN/CGA-2.17-M91, CSA - P.4.1-15, CSA C22.2 No.3 - M1998(R.2014).
This vented gas fireplace heater is not for use with air filters. Certified for use in both CANADA and USA.
VENTED GAS FIREPLACE HEATER-NOT FOR USE WITH SOLID FUEL.

	NG	LPG
Input rating	20,100 - 30,000 BTU/hr (5.9 - 8.8 kW)	23,000 - 30,000 BTU/hr (6.7 - 8.8 kW)
Manifold Pressure	1.6 - 3.5 in. W.C. (0.4 - 0.9 kPa)	6.0 - 10.0 in. W.C. (1.6 - 2.5 kPa)
Orifice size	#37 DMS (2.65 mm dia.)	#57 DMS (1.62 mm dia.)
Supply pressure (Min - Max)	5.0 - 14.0 in. W.C. (1.2 - 3.5 kPa)	11.0 - 14.0 in. W.C. (2.74 - 3.5 kPa)
Burner Primary Air Setting	1/4" (6 mm) Open	1/2" (13mm) Open
Altitude	0 - 4500 ft (0 - 1372 m)	0 - 4500 ft (0 - 1372 m)
Gas Control	SIT 885 Proflame II Dynamic Start with Continuous POD	
Electrical rating	120 VAC, 60 Hz, less than 2 A.	
Fireplace Efficiency (FE) Rating	68.45%	
Replacement fan	Part no. RF-305-0024 fan or blower assembly must be used	
Keep burner and control cover clean. See Instructions accompanying the heater. Optional fuel conversion kit : See Manual	Minimum clearances to Combustibles: Sides, back & top from standoffs: 0" (0 mm). Sides from Faceplate: 1" (25 mm) Max 6" (150 mm) mantle at min 45" (1143 mm) from bottom of appliance. Venting: Sides & Bottom: 1" (25 mm), Top: 2" (50 mm). Ceiling: 84" from bottom of appliance. See Manual for additional dimensions and clearances	

This appliance must be installed in accordance with local codes, if any; if none, follow the National Fuel Gas Code, ANSI Z223.1/NFPA 54, or Natural Gas and Propane Installation Codes, CSA B149.1. Electrical connections and grounding must be in accordance with local codes, if any; if none, follow the current CAN/CSA C22.1 in Canada and ANSI/NFPA 70 in the US. This appliance is certified for installation in a bedroom or a bed sitting room. This appliance is only for use with the gas indicated on the rating plate and may be installed in an aftermarket, permanently located, manufactured (mobile) home where not prohibited by local codes. See owner's manual for details. This appliance is not convertible with other gases, unless a certified kit is used.

WARNING: Improper installation, adjustment, alteration, service, or maintenance can cause injury or property damage. Refer to the owner's information manual provided with this appliance. For assistance or additional information consult a qualified installer, service agency, or the gas supplier. This appliance must be properly connected to a Direct Vent venting system in accordance with the manufacturer's installation instructions.

WARNING: Failure to install this appliance per the manufacturer's instructions or failure to use only parts specifically approved with this appliance may result in property damage or personal injury.

WARNING: Do not operate the appliance until all sections have been assembled and installed in accordance with the manufacturer's instructions.

WARNING: Operation of this appliance when not connected to a properly installed and maintained venting system can result in carbon monoxide (CO) poisoning and possible death.

ONLY DOORS CERTIFIED WITH THE APPLIANCE SHALL BE USED.
For use only with barrier part # 72-BS. Follow installation instructions.

Made in Canada by:
Archgard Industries Ltd.
300 Railway Avenue, Raymond, AB

October 03, 2024 303-6800-05

MANUFACTURE DATE:



Installation Checklist

This standard installation checklist is to be used by the installer in conjunction with, not instead of, the instructions contained within this installation manual.

Customer: _____	Date Installed: _____	
Install Address: _____	Location of Fireplace: _____	
	Installer: _____	
Appliance Install:	YES	IF NO, WHY NOT?
Standoffs and side nailing flanges are installed.		
Fireplace is leveled and secured.		
Venting:	YES	IF NO, WHY NOT?
Venting configuration complies with vent diagrams.		
Venting installed and secured in place maintaining proper clearances.		
Maintained 1/4" rise for every 1 ft. on horizontal run.		
Terminations installed and sealed in compliance with local building code.		
Direct vent termination is highest point in vent assembly.		
Wiring / Electrical:	YES	IF NO, WHY NOT?
Connected to household 110/120v per local codes.		
Unit is properly grounded.		
Gas:	YES	IF NO, WHY NOT?
Proper appliance for fuel type?		
Was a conversion performed?		
Leak check performed & inlet and manifold pressures verified?		
Verified proper air shutter setting?		
Finishing	YES	IF NO, WHY NOT?
Only noncombustible material installed in noncombustible areas.		
Clearances meet installation manual requirements.		
Mantels and/or projections comply with install manual.		
Appliance Setup:	YES	IF NO, WHY NOT?
Burner media / log set, glass door, and screen or Eclipse front installed according to manual		
Manual given to home owner.		
Did you check flame modulation?		
Comments: _____		

Safety Information

Caution

FOR YOUR SAFETY - Do not install or operate your **72-DVTE30-2** without reading and understanding this manual. Any installation or operational deviation from this instruction manual voids the warranty and may prove hazardous.

- This appliance must be installed by a qualified gas installer and the installation must conform to the installation codes
- Provide adequate clearance around air openings into combustion chamber
- Never obstruct front openings
- Provide adequate clearances for proper operation and servicing of the appliance
- This appliance must be properly connected to an approved venting system and must not be connected to a chimney flue serving a separate solid fuel burning appliance
- Flow of combustion and ventilation air must not be obstructed - always provide adequate combustion and ventilation air
- Always provide adequate clearance around the intake and exhaust openings

Safety

- Due to high temperatures, the appliance should be located out of traffic and away from furniture and draperies
- Children and adults should be alerted to the hazards of high surface temperature and stay away to avoid burns or clothing ignition
- If this appliance is installed directly on carpeting, tile, or other combustible material other than wood flooring, the appliance shall be installed on a metal or wood panel extending the full width and depth of the appliance
- Young children should be carefully supervised when they are in the same room as the appliance. Toddlers, young children and others may be susceptible to accidental contact burns. A physical barrier is recommended if there are at risk individuals in the house. To restrict access to a fireplace or stove, install an adjustable safety gate to keep toddlers, young children and other at risk individuals out of the room and away from hot surfaces
- Do not store or place combustibles, gasoline, and other flammable vapors and liquids near the appliance
- Clothing or other flammable material should not be placed on or near the appliance
- **WARNING:** Do not operate appliance with the glass front removed, cracked, or broken. Removal of the glass should be done by a licensed or qualified service person. Do not to strike or slam the glass
- Any safety screen or guard removed for servicing an appliance must be replaced prior to operating
- Installation and Repair should be done by a qualified service person. The appliance should be inspected before use and at least annually by a professional service person. More frequent cleaning may be required due to excessive lint from carpeting, bedding materials, etc. It is imperative that the control compartments, burners and circulating air passageways of the appliance are kept clean
- Under no circumstances should any solid fuel (wood, coal, paper or cardboard, etc.) be used in this appliance
- Keep burner and control compartment clean
- Do not use this appliance if any part has been under water. Immediately call a qualified service technician to inspect the appliance and to replace any part of the control system and any gas control which has been under water
- **California Proposition 65 Warning:** This product can expose you to chemicals including Carbon Monoxide, that is an externally vented by-product of fuel combustion, which is [are] known to the State of California to cause cancer, birth defects, or other reproductive harm. For more information, visit www.P65Warnings.ca.gov.

Each Archgard Gas Fireplace is checked and tested at the factory prior to being packaged and shipped to our dealers and finally installed in your home. Before leaving this unit with the customer, the installer must ensure that the appliance is firing correctly and that the electrical system is in working order. The Installation Checklist should be used to ensure the proper installation of this gas fireplace heater and to document any deviations from a typical install.

Any alteration to the product that causes carbon or soot deposits that results in any damage or requires cleaning is not the responsibility of the manufacturer.

APPLIANCE CERTIFICATION

This appliance is tested and safety approved under the following US and Canadian gas appliance standards:

- ANSI Z21.88-2019 / CSA 2.33-2019, Vented Gas Fireplace Heaters,
- CAN/CGA-2.17-M91(R2104), Gas-Fired Appliances for Use at High Altitudes,
- CSA – P.4.1-15 – Testing Method for Measuring Annual Fireplace Efficiency,
- CSA C22.2 No.3 - M1998(R.2014) - Electrical Features of Fuel-Burning Equipment

Commonwealth of Massachusetts: This appliance has been manufactured in accordance with Massachusetts code 248 CMR 5.00. **Approval Code: G1-0319-387** . (<http://license.reg.state.ma.us/public/licque.asp>).

Please contact Archgard Industries Ltd., if you have any questions regarding the certification of this appliance.

INSTALLATION CODES

This appliance must be installed by a qualified gas appliance installer. The installation must conform with the local codes or, in the absence of local codes, with the current National Fuel Gas Code, ANSI Z223.1/ NFPA 54, in the US or Installation Code, CAN/CGA-B149.1, in Canada. Electrical connections and grounding must conform with local codes, or current National Electrical code, ANSI/NFPA No. 70-1987, in the US and in Canada, the current Canadian Electrical Code, CSA C22.1.

We recommend that our gas hearth products be installed and serviced by professionals who are certified in the U.S. by the National Fireplace Institute® (NFI) as NFI Gas Specialists.

SPECIFICATIONS

	Natural Gas (NG)	Propane (LP)
Manifold Pressure	1.6 - 3.5 in. w.c. (0.4 - 0.9 kPa)	6.4 - 10.0 in. w.c. (1.6 - 2.5 kPa)
Min. Supply Pressure	5.0 in. w.c. (1.2 kPa)	11.0 in. w.c. (2.74 kPa)
Max Supply Pressure	14.0 in. w.c. (3.5 kPa)	14.0 in. w.c. (3.5 kPa)
Orifice Size	#37 DMS (2.65 mm dia.)	#52 DMS (1.62 mm dia.)
Nominal Input Rating	20,100 - 30,000 BTU/hr (5.9 - 8.8 kW)	23,000 - 30,000 BTU/hr (6.7 - 8.8 kW)
P.4 Fireplace Efficiency (FE)	68.45%	
P.4 Steady State Efficiency	68.49%	
Electrical Rating	120 VAC, 60 Hz less than 2 A.	
Gas Control	SIT 885 Proflame II Dynamic Start Advantage with Continuous Pilot on Demand	
Altitude	0-4500 ft (0 - 1372 M)	0 - 4500 ft (0 - 1372 M)
Primary Air Opening	¼" (6 mm) OPEN	½" (13 mm) OPEN

HIGH ALTITUDE INSTALLATION

When installing this appliance beyond 4500 ft. (1372m) above sea level, the appliance must be properly de-rated and installed according to local codes; in the absence of local codes, with the current National Fuel Gas Code, ANSI Z223.1/ NFPA 54 in the U.S., or Installation Code CAN/CGA-B149.1 in Canada.

GAS CONNECTIONS

Before connecting the appliance to the gas supply line, double check that the appliance you have purchased is designed for the gas type you are using. The gas type markings are located on the certification label and also on the appliance's gas valve.

Adequate clearance for proper installation and checking of the gas connections must be provided. **All gas connections must be checked for gas leaks.**

Have your gas supplier or a qualified gas fitter run a gas supply line into the fireplace. The line must be properly sized and fitted according to the installation codes. Immediately upstream of the supply connection, the fitter shall provide an accessible manual shut-off valve and a 1/8" (3mm) NPT plugged tapping accessible for connection to a test gauge. When connecting the supply line to the gas valve, the installer should brace the gas valve to ensure that it is not moved from its bracket. If the valve is not braced when the supply line is connected, the valve may be moved and cause a "break" in the main burner supply line. Such damage is not covered by the manufacturer's warranty.

CAUTION: The appliance and its individual shutoff valve must be disconnected from the gas supply piping system during any pressure-testing of that system at test pressures in excess of 1/2 psig (3.5 kPa). The appliance must be isolated from the gas supply piping system by closing its individual manual shutoff valve during any pressure-testing of the gas supply piping system at test pressures equal to or less than 1/2 psig (3.5 kPa). Failure to do so will damage the appliance's gas valve. Such damage is not covered by the manufacturer's warranty.

Natural Gas Pressure Settings:

The inlet supply or line pressure must be a minimum of 5.0" W.C. (1.2 kPa) and a maximum of 14.0" W.C. (3.5 kPa). The orifice is a #37 DMS (2.65 mm) drill size.

<u>ELEVATION</u>	<u>INPUT RATING</u>
0-4500 ft (0-1372 M)	30,000 BTU/hr (8.8 kW)
4500 ft (1372 M) and above	30,000 BTU/hr (8.8 kW) less 4% per 1000 ft. (305 M)

Please contact your local distributor for the appropriate orifice size you require.

Propane Pressure Settings:

The inlet supply or line pressure must be a minimum of 11.0" W.C. (2.8 kPa) and a maximum of 14.0" W.C. (3.5 kPa). The orifice is a #52 DMS (1.62 mm) drill size.

<u>ELEVATION</u>	<u>INPUT RATING</u>
0-4500 ft. (0-1372 M)	30,000 BTU/hr (8.8 kW)
4500 ft. (1372 M) and above	30,000 BTU/hr (8.8 kW) less 4% per 1000 ft. (305 M)

Please contact your local distributor for the appropriate orifice size you require

NOTE: THE INPUT RATING SHOULD ALWAYS BE CHECKED WHEN FIRST RUNNING THIS APPLIANCE. To do this, reduce the background flow rate, time the meter, light the fireplace and take another reading after 15 minutes of operation. Check with your gas supplier for the gas BTU content at your elevation. Input is the rate of flow multiplied by the heating value of the gas (cubic feet/hour x BTU per cubic feet). Adjust the manifold pressure so that the unit does not operate above the rated input.

APPLIANCE DIMENSIONS

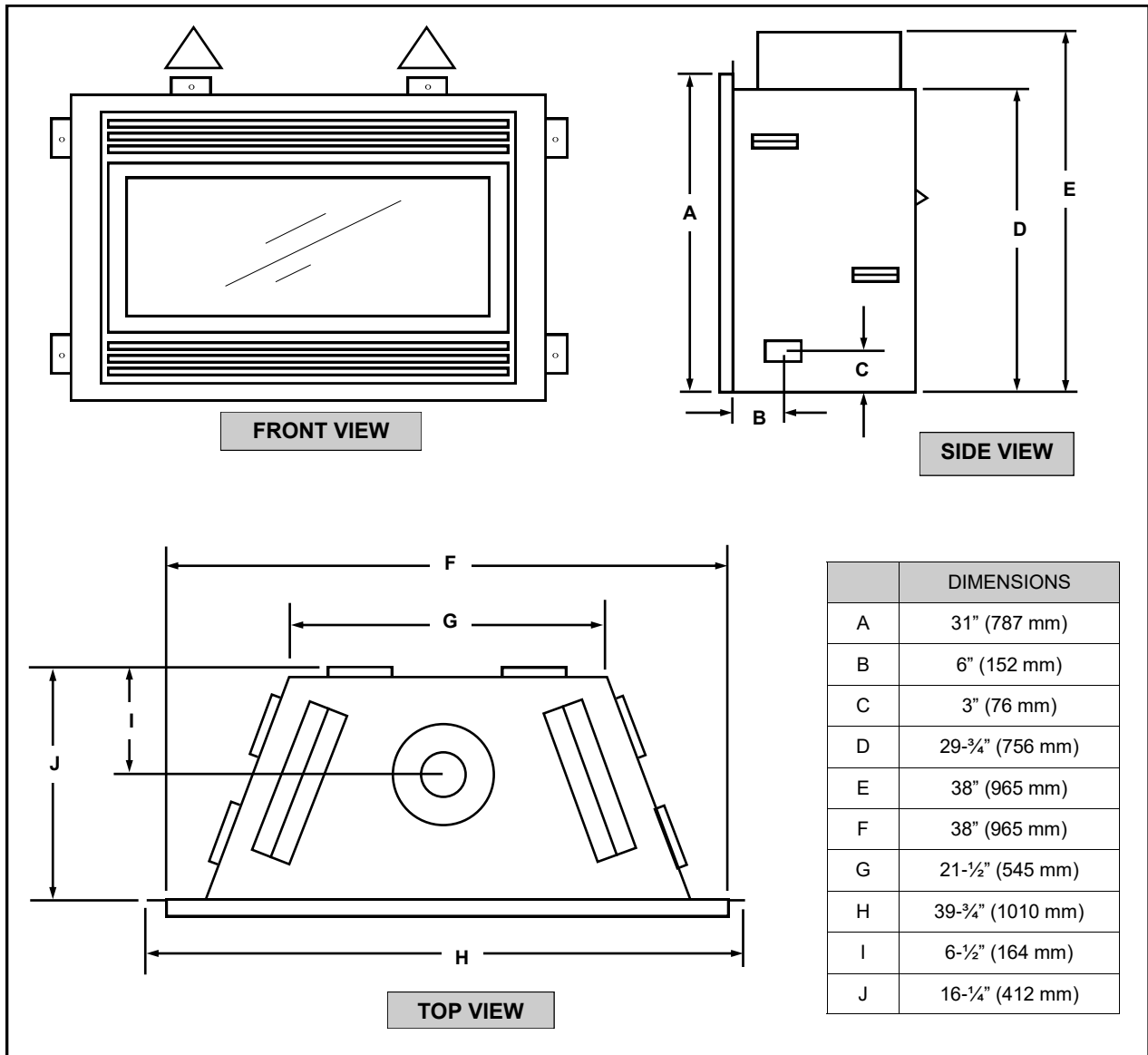

CLEARANCES TO COMBUSTIBLES

BACK	0" to stand-offs
SIDES	0" to stand-offs
TOP	0" to stand-offs
BOTTOM	0"
ADJACENT SIDE WALL	1" (25 mm) to side of faceplate
MANTLE	see diagram
VENT	1" (25 mm) to outside side and bottom surface, 2" (50 mm) to outside top surface.

MANTLE CLEARANCE

NOTE:

Low profile wooden crowns and moldings above the unit are not considered as mantles. I.E. 1" (25 mm) or less protrusions on the upper mantle facing are acceptable.

Combustible mantle allowed in shaded area. Mantle extension may be increased 1" (25 mm) for each additional 1" (25 mm) increase in clearance height.

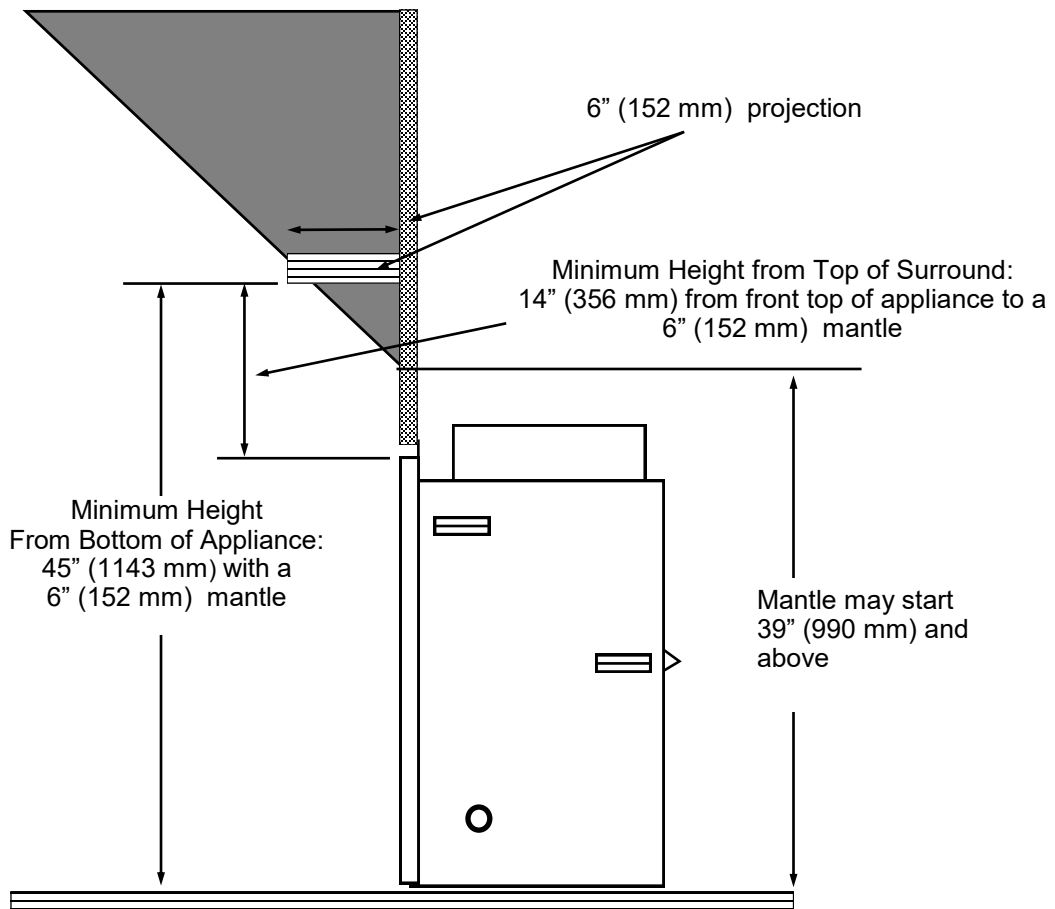

Heat Sensitive Flooring Materials

Archgard fireplaces are heating products, designed to produce a large amount of radiant and convective heat. The clearances specified above are intended to be minimum clearance distances to combustible materials, however, flooring directly adjacent to the minimum hearth clearances may reach temperatures of up to 180°F (82°C) or higher depending on the installation.

Please check with your flooring manufacturer for temperature tolerances as some materials, such as vinyl, tend to be more sensitive to temperatures above average room temperature and may be damaged or warped if exposed to heat.

We recommend testing any flooring material to ensure that it can withstand temperatures generated by this fireplace. If the tolerances of the flooring material are not known or are not capable of withstanding the temperatures generated by this fireplace, install a heat pad constructed of material that is not sensitive to heat, or adjust clearances to heat sensitive materials as shown below.

Note: clearances shown are the width of the fireplace door. The dimensions shown are guidelines only and cannot account for all flooring materials. The dimensions shown do not replace the hearth clearances for this product. Always maintain the clearances to combustible materials as shown on the previous page.

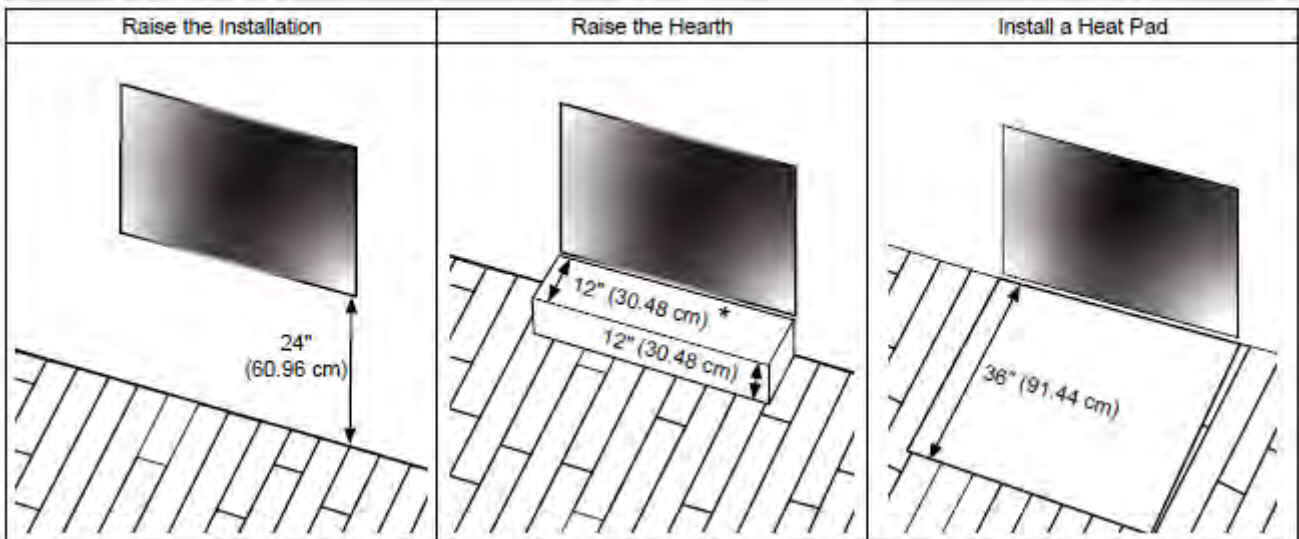

* Use whichever distance is greater when compared to the hearth clearances.

FRAMING DIMENSIONS

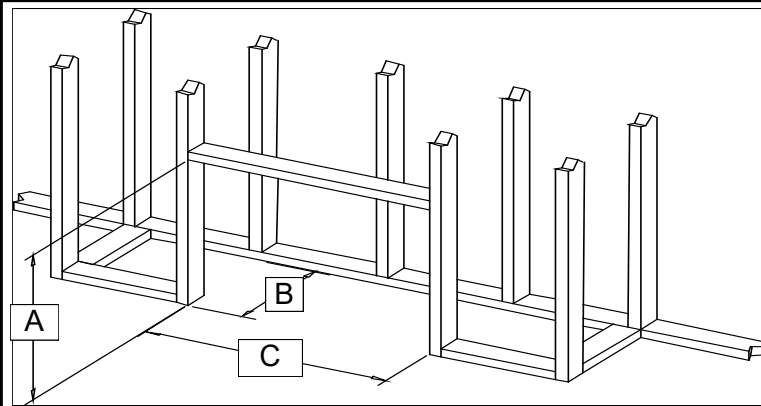

Dimensions	
A	* 38" (965 mm)
B	16-1/4" (412 mm)
C	38" (965 mm)

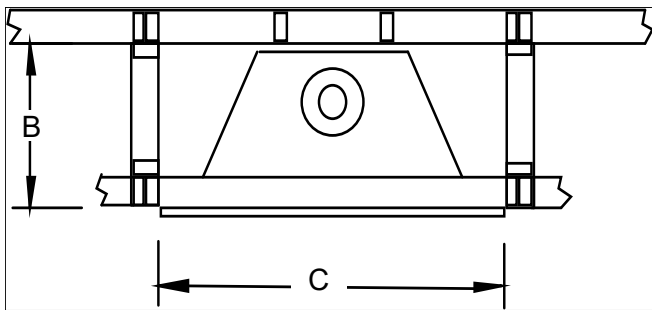

* This dimension allows the top of the fireplace to slide under. If more rigidity is required, a steel stud may be added to the back of the fireplace top nailing flange after the fireplace is installed.

CORNER FRAMING

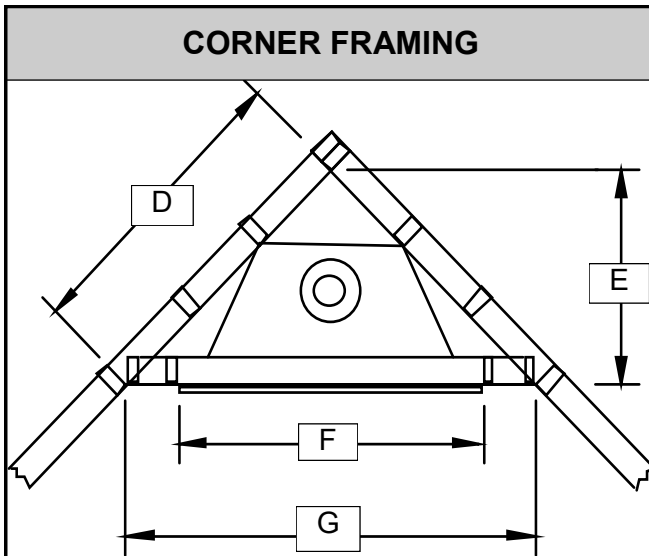

DIMENSIONS	
D	39-1/8" (994 mm)
E	27-5/8" (700 mm)
F	38" (965 mm)
G	55-1/4" (1403 mm)

TERMINATION FRAMING

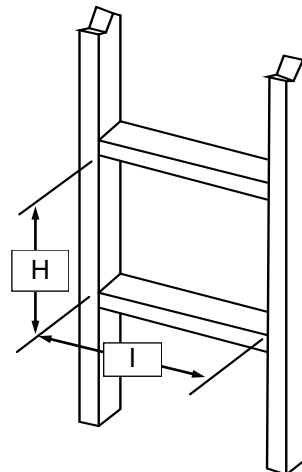

DIMENSIONS	
H	11" (279 mm)
I	10" (254 mm)

NOTE: Be sure to include 1/4" (6mm) rise per 12" (305 mm) of horizontal length

LOCATING GAS FIREPLACE

This appliance must be installed in any location that is free of plumbing, electrical wiring and heating or air conditioning ducts. Select a location that is accessible for venting.

See ALLOWABLE TERMINATION LOCATIONS listed in this manual. The fireplace may be installed in any location that maintains proper clearances to combustibles, air conditioning ducts, electrical wiring and plumbing. Select a location that is accessible for venting See section Allowable Termination Locations listed in this manual. When the appliance is installed directly on carpeting, vinyl tile or other combustible materials, other than wood flooring, the appliance must be installed on metal or wood panel extending the full width and depth of the appliance.

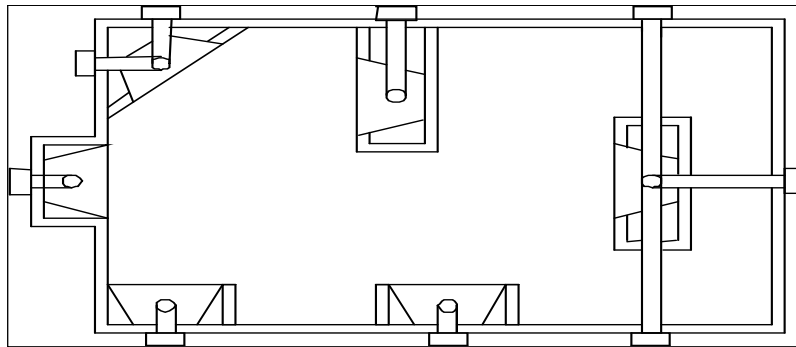

NOTE:

See venting chart for maximum and minimum vertical / horizontal venting configurations.

VENT TERMINATION LOCATIONS

ALLOWABLE TERMINATION LOCATIONS and establish a suitable vent termination location.

1. In heavy snowfall areas make sure the vent termination is located where it can not be blocked by snowfall and / or snow from snow-removal equipment.
2. Locate the vent termination away from plants, bushes or any other object near the vent termination that will interfere with or obstruct the airflow around it.
3. DO NOT recess vent termination into walls, sidings or planters.
4. Vent terminations located below 7ft (2.13 M) from grade level or anywhere that it can be a burn hazard to the public, such as patios and balconies, must be protected with an approved termination cage. If using Archgard Venting System, order Part # C-1.

ALLOWABLE TERMINATION LOCATIONS

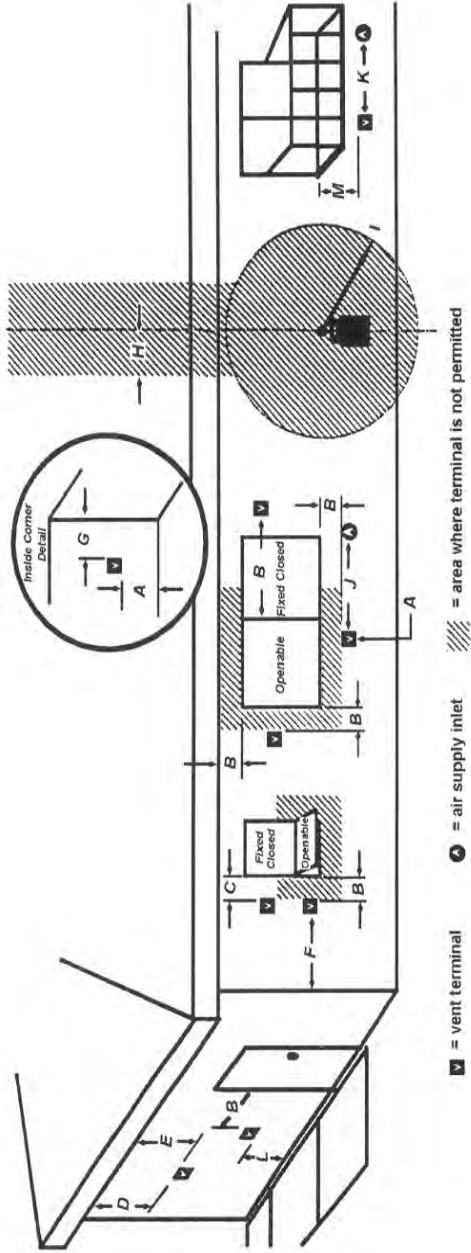

	Canadian Installations (1)	US Installations (2)	Canadian Installations (1)	US Installations (2)
A= Clearance above grade, veranda, porch, deck, or balcony	12 inches (30 cm)	12 inches (30 cm)	12 inches (30 cm)	9 inches (23 cm)
B= Clearance to window or door that may be opened	12 inches (30 cm)	12 inches (30 cm)	6 feet (1.83 m)	3 feet (91 cm) above if within 10 feet (3 m) horizontally
C= Clearance to permanently closed window	*	*	7 feet (2.13 m) +	*
D= Vertical clearance to ventilated soffit located above the terminal within a horizontal distance of 2 feet (61 cm) from the center line of the terminal	*	*	12 inches (30 cm) ++	*
E= Clearance to unventilated soffit	*	*		
F= Clearance to outside corner	*	*		
G= Clearance to inside corner	9" (22.5cm)	9" (22.5cm)		
H= Clearance to each side of center line extended above meter/regulator assembly	3 feet (91 cm) within a height 15 feet (4.5 m) above the meter/regulator assembly	*		
L= Clearance to service regulator vent outlet	3 feet (91 cm)	*		

(1) In accordance with the current CSA B149.1, *National Gas and Propane Installation Code*

(2) In accordance with the current ANSI Z223.1/NFPA 54, *National Fuel Gas Code*

(+) A vent shall not terminate directly above a side walk or paved driveway that is located between two single family dwellings and serves both dwellings

(++) Permitted only if veranda, porch, deck, or balcony is fully open on a minimum of two sides beneath the floor.

(*) For clearances not specified in ANSI Z223.1/NFPA 54 or CSA B149.1, "Clearances shall be in accordance with local installation codes and the requirements of the gas supplier."

APPROVED VENT COMPONENTS

The appliance will not function without being connected to a proper venting system. This appliance may only use direct vent system supplied by Archgard Industries or Simpson Dura-Vent direct vent systems with the appropriate adaptor dependent upon the venting guidelines within this manual.

NOTE: Only the venting components listed below are approved for the 72-DVTE30-2

PART #	DESCRIPTION
999-DV-TVK3	Archgard Flex Vent Kit with 36" (914 mm) vent length (includes 999-DV-HTC)
999-DV-TVK5	Archgard Flex Vent Kit with 60" (1.52 M) vent length (includes 999-DV-HTC)
999-DV-DV-HTC	Archgard Horizontal termination head only
999-DV-SC	Archgard Safety Cage for Horizontal termination head (999-DV-HTC)
999-DV-VSD	Archgard Vinyl siding deflector
999-DV-SDA	Universal Adapter, Simpson Dura-Vent / Flex
DV-GS	Simpson Dura-Vent venting system

VENTING CONNECTION

For best and safe venting performance, here are some general venting rules:

- Use only Archgard or Simpson Dura-Vent direct vent systems and components.
- **Maintain a minimum of 1" (25mm) clearance to combustibles from the outside surfaces of vertical vents and minimum of 1" (25mm) sides and bottom, and 2" (50mm) from top surfaces of horizontal vents.**
- Observe local code restrictions, if any, regarding the installation of this type of gas appliance.
- **Observe the venting charts given in this manual.**
- Use vent spacers between the inside 4" (101mm) and outside 7" (178mm) vents at 3 ft (915mm) intervals (Archgard Direct Vent System ONLY).
- **Never slope horizontal vents downwards towards the vent termination.**
- **Maintain a minimum ¼" rise (6mm) for every linear foot (305mm) of horizontal vent.**
- Terminate (Horizontally) the vent only with an approved vent termination supplied by Archgard Industries (Part # 999-DV-HTC) or Simpson Dura-Vent Termination Cap.
- Terminate (Vertically) the vent only with Simpson Dura-Vent Vertical Termination Cap.
- **Support horizontal vents every 3 ft (915mm) to prevent sagging.**

Please strictly follow the venting instructions for optimum performance from the appliance and to avoid sooting and/or service calls.

VENTING - RESTRICTOR PLACEMENT

RESTRICTOR PLACEMENT FOR ROOFTOP VENTED APPLICATIONS ONLY

WARNING: These restrictors are only to be installed in the vent system if the vent exceeds 10' in vertical height. Restrictor Number 1 below is required if the vent system is between 10'-18' and Restrictor Number 2 below is required if the vent system exceeds 18'. **Installing them under any other circumstances may cause hazardous venting conditions and may result in personal injury, property damage or death.**

NOT FOR USE IN SIDEWALL VENTED APPLICATIONS

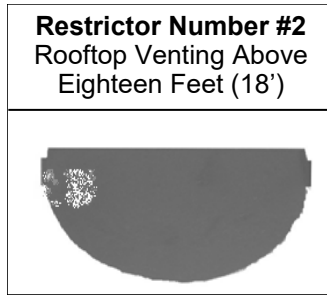
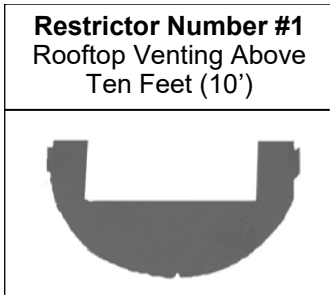

NOTE: Vent restrictors are designed to reduce vertical stack action for vent terminations which will reduce the velocity of incoming combustion air and not adversely affect the standing pilot or the efficiency of the appliance.



VENTING - VERTICAL TERMINATION CHART

The appliance will not function without being connected to a proper venting system. This appliance may only use direct vent system approved by Archgard, or Simpson Dura-Vent direct vent systems with Archgard 999-DV-SDA adapter.

VENTING CHART

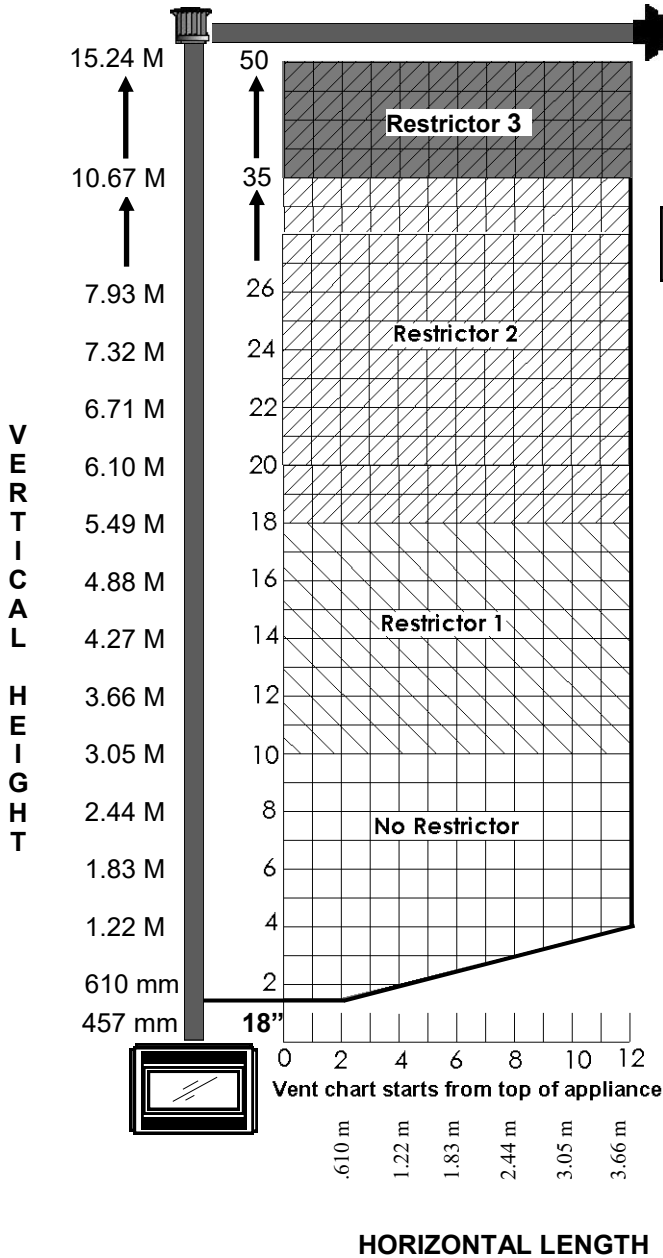

SEE PAGE 14 FOR RESTRICTOR SHAPE & PLACEMENT

NOTE: NO INSTALLATIONS ARE PERMITTED OUTSIDE OF THIS RANGE

- Minimum 18" rise vertical required
- Chart is for one 90° bend, with a 1/4" (6 mm) minimum vertical rise per running foot of horizontal length.
- For each additional 90° or two 45°, add one foot of vertical height.
- Maximum three 90° bends, or equivalent allowed in the system.
- Minimum 2 ft (610 mm) straight length between bends.

VENTING ABOVE ROOF OF THE HOUSE USING A VERTICAL TERMINATION

Use Simpson Dura-Vent listed direct vent system caps for all vertical vent termination applications (through the roof).

Please strictly follow the venting instructions for optimum performance from the appliance and to avoid sooting and/or service calls.

VENTING - VERTICAL TERMINATION USING SIMPSON DURA-VENT PIPE ONLY

The 72-DVTE30-2 can be vented vertically using Simpson Dura-Vent Direct Vent System. To vent using Simpson Dura-Vent exclusively, you must use the Archgard 999-DV-SDA Adapter and connect the adapter to the top of flue outlet on the Optima 72 gas fireplace.

1. Maintain 1" (25mm) clearance (air space) to combustibles when passing through ceilings, walls, roof, enclosures, attic rafter, or other nearby combustible surfaces. Do not pack air spaces with insulation. Check **Page 15** (Venting Chart) for the maximum vertical rise of the venting system.
2. Set the gas appliance in its desired location. Drop a plum bob down from the ceiling to the position of the appliance flue exit, and mark the location where the vent will penetrate the ceiling. Drill a small hole at this point. Next, drop a plumb bob from the roof to the hole previously drilled in the ceiling, and mark the spot where the vent will penetrate the roof.

NOTE: you may wish to relocate the appliance to avoid cutting load-bearing members.

3. A Firestop spacer must be installed in the floor or ceiling of every level. To install the Firestop spacer in a flat ceiling cut a 10" (254mm) square hole. Frame the hole as shown Fig. 1 and install the firestop.
4. Assemble the desired lengths of pipe and elbows as outlined in the Venting Chart, necessary to reach from the Appliance adaptor (999-DV-SDA). Ensure that all Simpson Dura-Vent and/or flexible gas liners are connected and sealed accordingly.
5. Cut a hole in the roof centered on the small drill hole placed in the roof as outlined in Step 2.
6. The hole should be of sufficient size to meet the minimum requirements for each combustibles of 1" (25mm). Slip the flashing under the shingles (shingles should overlap half of the flashing) as per Fig.2.
7. Continue to assemble pipe lengths and/or flexible gas venting.
8. Ensure vent is vertical and secure the base of the flashing to the roof with roofing nails; slide storm collar over the section and seal with a mastic.
9. Install the vertical termination cap by twist-locking it.

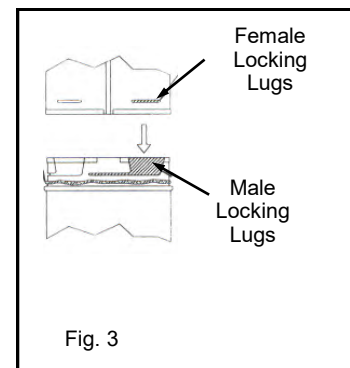
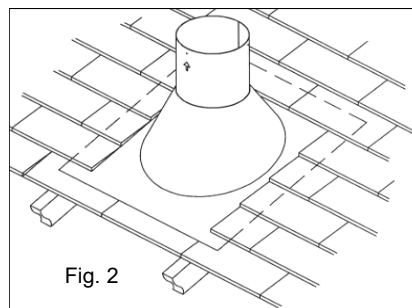
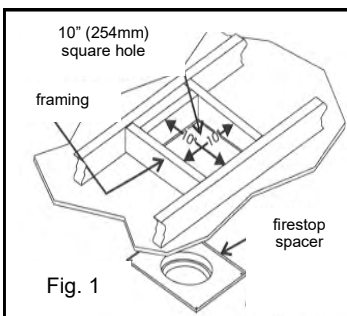

VENTING - VERTICAL TERMINATION USING SIMPSON DURA-VENT PIPE ONLY

NOTE:

- Galvanized pipe is desirable above the roofline due to its higher corrosion resistance. Continue to add pipe sections throughout the flashing until the height of the vent cap meets the minimum height requirements specified in Fig. 5. or local codes.
- For steep roof pitches, the vertical height must be increased. A poor draft, or down drafting can result in high wind conditions, trees or neighbor's roof lines. In these cases, increasing the height may solve a drafting problem. **REMEMBER** to check that you are within the maximum vertical height restrictions, and are placing the appropriate vent restrictors as outlined in the venting chart within this manual.
- Any storage spaces or closets which the vent must pass through must be enclosed.

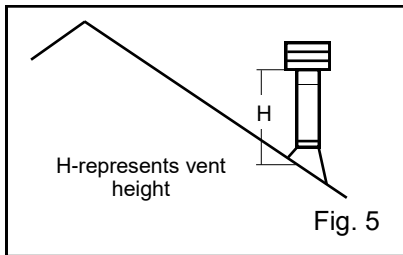

Roof Pitch	Minimum Vent Height	
Flat to 7/12	2 Feet	0.61 Meters
Over 7/12-8/12	2 Feet	0.61 Meters
Over 8/12-9/12	2 feet	0.61 Meters
Over 9/12-10/12	2.5 Feet	0.76 Meters
Over 10/12-11/12	3.25 Feet	1.00 Meters
Over 11/12-12/12	4 Feet	1.22 Meters
Over 12/12-14/12	5 Feet	1.52 Meters
Over 14/12-16/12	6 Feet	1.83 Meters
Over 16/12-18/12	7 Feet	2.13 Meters
Over 18/12-20/12	7.5 Feet	2.29 Meters
Over 20/12-21/12	8 Feet	2.44 Meters

Typical Vertical venting configuration using Simpson Dura-Vent Direct Vent System

Simpson Dura-Vent venting components are listed on page 22

VENTING - VERTICAL TERMINATION USING FLEX GAS LINER

The 72-DVTE30-2 can be used with Flexmaster Model GA 4" & 7" (101mm & 178mm) vent liners, and terminate through the roof using Simpson Dura-Vent by using an 999-DV-SDA (Adapter, Flex to Simpson Dura-Vent).

- Refer to the venting chart before considering vertical termination.
- Check the Allowable Termination Locations chart within this manual.

CONNECTING THE 999-DV-SDA ADAPTER TO FLEX & SIMPSON DURA-VENT

FLEXIBLE PIPE CONNECTIONS

1. The intake pipe must be securely fastened to the appliance and to the terminal and all joints must be secured using a minimum of 3 screws evenly spaced around the pipe.
2. Approximately 1" (25mm) from the end of the 4" (101mm) pipe outlet at the appliance and at the 4" (101mm) terminal inlet, apply a bead of high temperature non-silicone sealant approximately 1/4" (6mm) wide. Slide the 4" (101mm) pipe onto the appliance and secure with 3 screws evenly spaced to the outlet. Repeat the procedure at the terminal inlet.
3. Install a vent spacer between the outer and the inner liner to maintain clearances. Spacers should be installed at every change of direction and every 3 ft. (914mm).
4. See Fig. 1 & 2 to determine where to place the 999-DV-SDA adapter, and connect the 999-DV-SDA adaptor as shown in Fig. 3.
5. Follow all vertical venting directions as outlined in the Vertical termination sections.

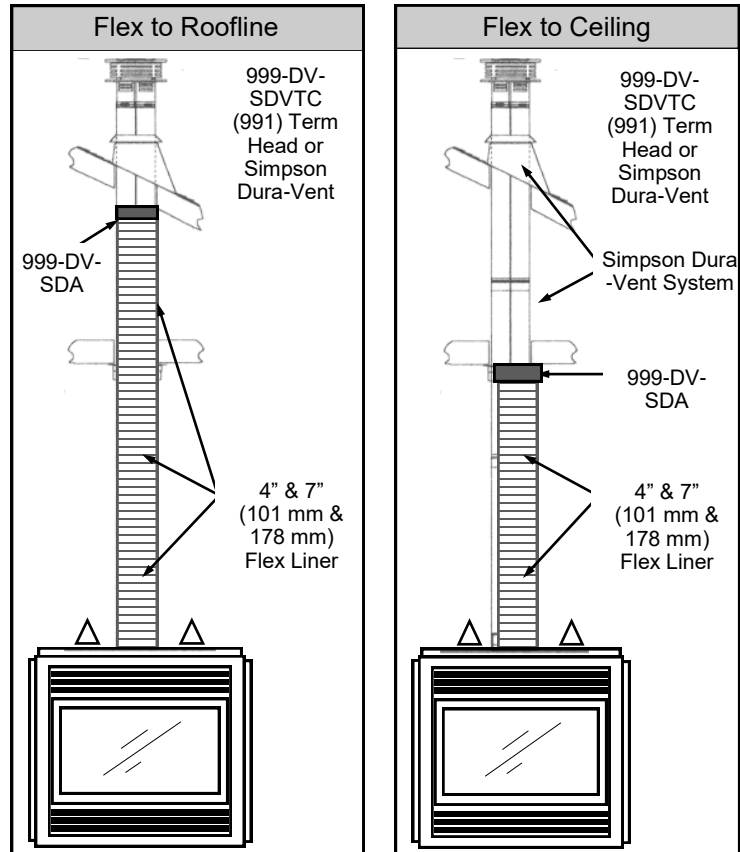

Connecting the SDA-U Adaptor

Slide the 4" (101mm) flex pipe over the 4" (101mm) section of the 999-DV-SDA adapter, and secure with a bead of mil-pac or other non-silicone sealant (**DO NOT use silicone**) and 3 screws. Repeat the process for the 7" (178mm) liner. Follow with Simpson Dura-Vent Pipe and guidelines for installation as outlined within this manual

Clearance to combustable material and fire-stops must be installed as required by local codes; in the absence of local codes, in accordance with the local enforcing authority.

VENTING - HORIZONTALLY USING FLEXIBLE DIRECT VENT SYSTEMS

The 72-DVTE30-2 can be vented Horizontally by using the Archgard Direct Vent System of flexible pipe.

PART #	DESCRIPTION
999-DV-TVK3	Flex Vent Kit with 36" (914 mm) vent length (includes 999-DV-HTC)
999-DV-TVK5	Flex Vent Kit with 60" (1.52 M) vent length (includes 999-DV-HTC)
999-DV-TVK10	Flex Vent Kit with 120" (3.05 M) vent length (includes 999-DV-HTC)
999-DV-HTC	Horizontal termination head only
999-DV-SC	Safety Cage for Horizontal termination head (999-DV-HTC)
999-DV-VSD	Vinyl siding deflector

VENT KIT COMPONENTS (TVK)

- 7" & 4" flexible liner (compressed)
- Telescoping Thimble
- Firestop
- Screws
- Sealant
- Horizontal Termination Cap
- Spring spacers

VENT ASSEMBLY

- 4" exhaust vent with spring spacers
- Fully Assembled Flexible Direct Vent System

NOTE: Pitch the flexible pipe up towards the Horizontal Termination Cap

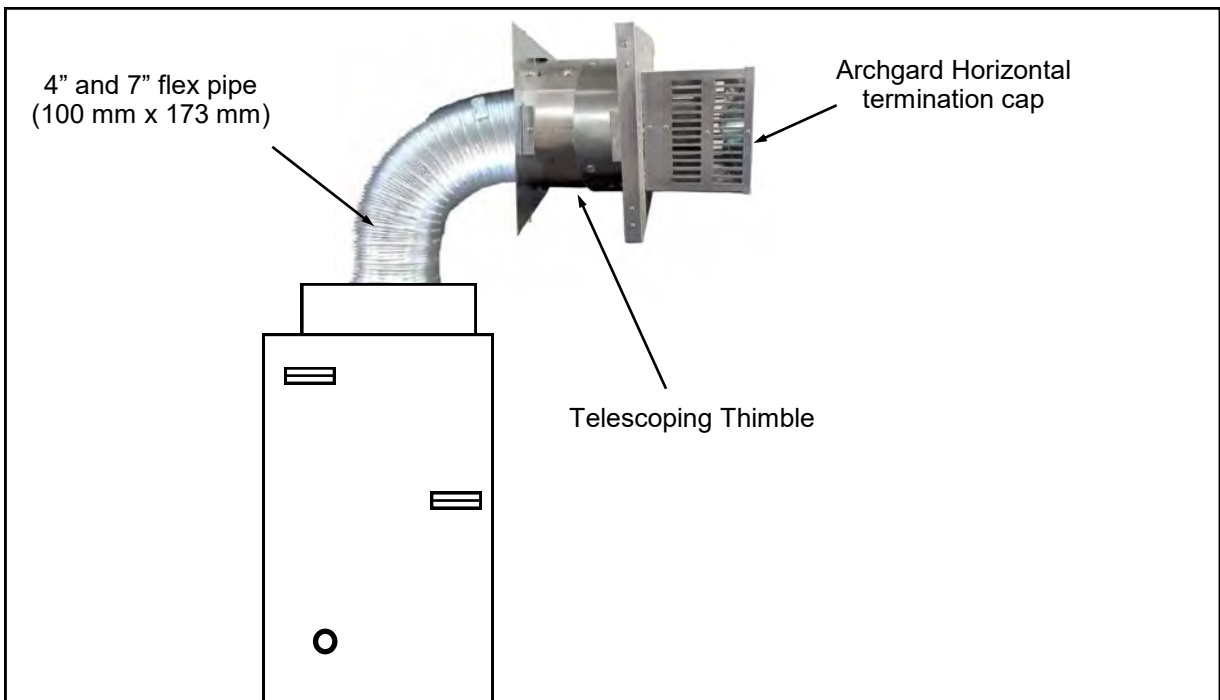

VENTING - HORIZONTALLY USING FLEXIBLE DIRECT VENT SYSTEMS**INSTALLATION PROCEDURES - ARCHGARD DIRECT VENT (FLEX) SYSTEM**

1. Place the 72-DVTE30-2 in the framing. Locate the centerline of the termination and mark the wall. Cut an 11" x 10" (279mm x 254mm) hole in the wall. NOTE: a 2" (50mm) x 1-1/2" (13mm) around the 7" (178mm) liner is required. See Fig.1 for termination framing.
2. Locate the Horizontal termination head and the 4" (101mm) flexible exhaust pipe, and "DRY" slip the exhaust pipe over the 4" (101mm) exhaust port on the termination head. Un-slip the "DRY" connection and apply high temperature non-silicone sealant to the 4" (101mm) flexible exhaust port and reattach to the 4" (101mm) exhaust connection on the termination head and fasten with three screws on the pre-drilled locations. Repeat this same process with the 7" (178mm) flexible liner.
3. Locate the wall sleeve and cut to the thickness of the wall and slip it through the wall.
4. Locate the Firestop and secure in place with 4 screws.
5. Pull / Straighten the inner 4" (101mm) exhaust pipe to its maximum capacity and "wrap" the spring spacers at every change of direction and every 3ft (914mm) if longer lengths of flexible liner is used. Next pull the 7" (178mm) intake liner over the 4" (101mm) exhaust liner.
NOTE: Take care when "pulling / stretching out the liners; inspect for "breaks" in the liners or in the termination head. Any "breaks" in the venting system will cause poor flame and improper combustion.
6. Slip the assembled liner and termination head through the wall sleeve and make sure the termination cap faces up and fasten the termination head to the wall with 4 screws provided with the kit.
NOTE: If installing the termination head to vinyl or wood siding a Vinyl Siding Deflector (999-DV-VSD) is required. The 999-DV-VSD must be set on top of the horizontal termination cap (fin side out) and then the two screws holding the termination cap are used to secure the termination head and 999-DV-VSD.
7. Apply high temperature non-silicone sealant over the fireplace's inner exhaust collar and slip the 4" (101mm) inner flexible exhaust liner down over it and attach the connection with three screws.
8. Repeat with the 7" (178mm) liner.
9. Apply a bead of all weather sealant (not provided) around the termination head & house to prevent water from entering in.

NOTES:

- If installing a Vinyl Siding Deflector (999-DV-VSD) attach the 999-DV-VSD to the front top of the horizontal termination head "fin side out" to ensure the termination head is not recessed into the siding.
- Horizontal sections of pipe **MUST** be supported every 3' (914mm).
- Spacers shall be installed at every change of direction and every 3' (914mm) if using additional flexible pipe.

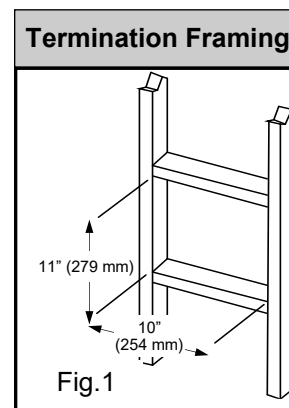

NOTE: Be sure to include 1/4" (6mm) rise per foot of horizontal length.

IMPORTANT: Do not locate termination head where excessive snow or ice buildup may occur. Check termination head area after every snow fall, and clear if necessary to prevent blockage. If using snow blowers, make sure snow is not directed at the termination head.

VENTING - HORIZONTALLY USING SIMPSON DURA-VENT DIRECT VENT SYSTEMS

The 72-DVTE30-2 can be vented horizontally using Simpson Dura-Vent Direct Vent System. To vent using Simpson Dura-Vent exclusively, you must use the Archgard 999-DV-SDA Adaptor and connect the 999-DV-SDA adaptor to the top of the Optima 72 as shown in Fig.1.

NOTE: Apply high temperature non-silicone sealant to the SDA-U adaptor and the flue connection on the Optima 72. Seal all pipe joints and follow all venting instructions within this manual.

NOTE: Call your local Authorized Archgard Dealer to purchase Simpson Dura-Vent Direct Vent Kits and/or venting components.

Minimum components required for horizontal termination using Simpson Dura-Vent:

1 999-DV-SDA (Appliance adaptor)	1 90 Deg. Elbow
1 Horizontal Termination Cap	1 Wall Thimble
1 Length of pipe for top of appliance	1 Length of pipe to suit wall thickness

Measure wall thickness from the back of the fireplace standoffs to the inside mounting surface of the termination cap. If a Vinyl siding standoff is required, measure to the outside surface of the wall without siding and add 2" (50mm).

NOTE: The Termination cap must NOT be recessed into siding. Measure wall thickness including finishing straps.

Flat Wall Installation			
Wall Thickness (inches)	Vent Length Required (inches)	Wall Thickness (mm)	Vent Length Required (mm)
4" - 5-1/2"	6"	101 mm - 140 mm	152 mm
7" - 8-1/2"	9"	178 mm - 216 mm	228 mm
10" - 11-1/2"	12"	254 mm - 292 mm	305 mm
9" - 14-1/2"	11" - 14-5/8" Adj. Pipe	228 mm - 368 mm	228 mm - 371 mm
15" - 23-1/2"	17" - 24" Adj. Pipe	381 mm - 597 mm	432 mm - 610 mm

Corner Installations			
Wall Thickness (inches)	Vent Length Required (inches)	Wall Thickness (mm)	Vent Length Required (mm)
3-1/4" - 6-3/4"	11" - 14-5/8" Adj. Pipe	82 mm - 171 mm	228 mm - 371 mm
7-3/4" - 16-1/4"	17" - 24" Adj. Pipe.	197 mm - 412 mm	432 mm - 610 mm
7-1/4" - 8-3/4"	6" + 12" Or 9" + 9"	184 mm - 222 mm	101 mm + 305 mm Or 228 mm + 228 mm
4-1/4" - 5-3/4"	6" + 9"	108 mm - 146 mm	152 mm - 228 mm

SIMPSON DURA-VENT DIRECT VENT PARTS LIST 6 5/8" x 4" (168mm x 101mm) See your Authorized Archgard Dealer for price and availability.

Part #	Description	Part #	Description	Part #	Description
971	Horiz. Term. Kit Includes; 90° Blk elbow, wall thimble cover, Horiz. square term. Cap, 24" (610 mm) blk pipe and 11"-14" (279 mm x 356 mm) adj. blk pipe.	902	48" (1.22 M) Pipe Length - Galv.	984	Horizontal (Square) Termination Cap
970	Basic Horiz. Term. Kit Includes; 90° blk elbow, wall thimble cover, Horiz. square term. cap.	902B	48" (1.22 M) Pipe Length - Black	985	Horiz. (SQ) Term. Cap. High Wind.
987	Vertical Termination Kit Includes; 0/12- 6/12 pitch adj. flashing, storm collar, low profile term. cap.	911B	11" - 14-5/8" (228 mm x 371 mm) Adj. Pipe Length - Black	982	Snorkel - 14" (356 mm) Rise Term. Cap
908B	6" (152 mm) Pipe Length - Black	917B	17" - 24" (432 mm) x (610mm) Adj. Pipe Length - Black	981	Snorkel - 36" (914 mm) Rise Term. Cap
907B	9" (228 mm) Pipe Length - Black	945	45° Elbow - Galv.	940	Wall Thimble - Support Box
906	12" (305 mm) Pipe Length - Galv.	945B	45° Elbow - Black	941	Cathedral/Ceiling - Support Box
906B	12" (305 mm) Pipe Length - Black	945G	45° Elbow - Swivel - Galv.	3951	Brass Trim for Wall Thimble/Ceiling Sup.
904	24" (610 mm) Pipe Length - Galv.	945BG	45° Elbow - Swivel - Black	963	Firestop Spacer
904B	24" (610 mm) Pipe Length - Black	990	90° Elbow - Galv.	943	Flashing 0/12 - 6/12
903	36" (914 mm) Pipe Length - Galv.	990B	90° Elbow - Black	943S	Flashing 7/12 - 12/12
903B	36" (914 mm) Pipe Length - Black	990G	90° Elbow - Swivel - Galv.	953	Storm Collar
		990BG	90° Elbow - Swivel - Black	950	Vinyl Siding Standoff
		991	Vertical Termination Cap High Wind	988	Wall Strap
		980	Vertical Termination Cap	942	Wall Thimble

VENTING - HORIZONTALLY USING SIMPSON DURA-VENT DIRECT VENT SYSTEMS

INSTALLATION PROCEDURES FOR SIMPSON DURA-VENT DIRECT VENT SYSTEM

1. Set the 72-DVTE30-2 in its desired location. Determine if wall studs or roof rafters are in the way when venting system is attached. You may want to adjust the location of the unit to compensate.
2. Simpson Dura-Vent Venting System is designed with special twist-lock connections to connect to the appliance. An Archgard adaptor (999-DV-SDA) is required. The adaptor will allow Simpson Dura-Vent System to be used.
3. Apply a bead of sealant inside the outer section of the 999-DV-SDA adaptor. Slip the adaptor over the existing inner and outer flue collar and fasten it to the outer collar only with 3 screws (drill pilot holes first). Level the appliance and fasten it to the framing using nails or screws through the nailing strips.
4. Assemble the desired combination of pipe and elbows to the appliance adaptor and twist lock the pipe.

NOTE: Twist-lock procedure: Four indentations, located on the female ends of the pipes and fittings, are designed to slide straight onto the male ends of adjacent pipes and fittings by orientating the four pipe indentations so they match and slide in to the four entry slots on the male ends (Fig. 2.). Push the pipe sections completely together, then twist-lock one section clockwise approximately one quarter turn, until the two sections are fully locked. The female locking lugs will not be visible from the outside, on the pipe or fittings. They may be located by examining the inside of the female ends. Horizontal vent runs **MUST** be supported every three feet (76 mm). Wall straps are available for this purpose.

NOTE: Follow venting horizontal venting chart and Allowable Termination locations guidelines.

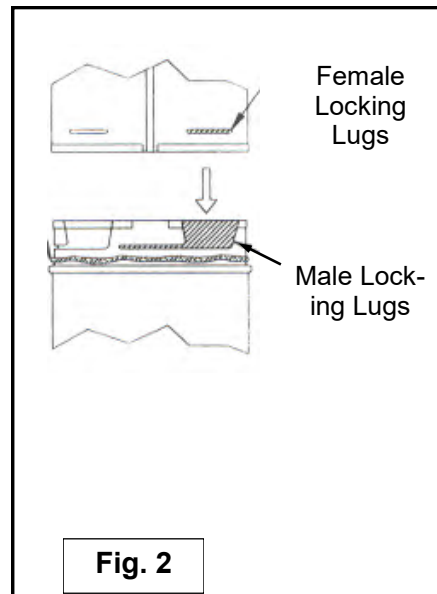
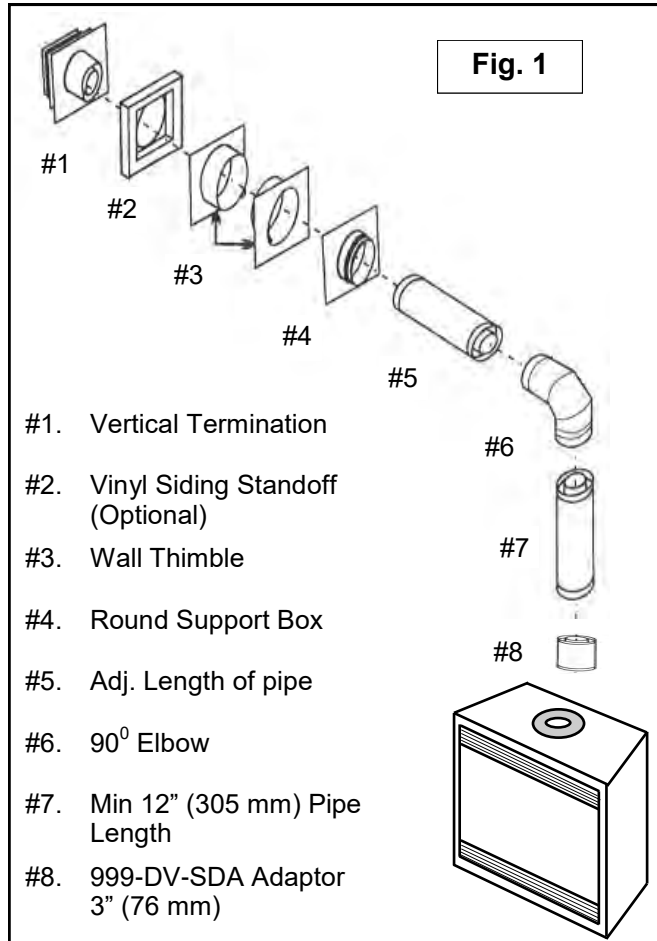

VENTING - HORIZONTALLY USING SIMPSON DURA-VENT DIRECT VENT SYSTEMS

INSTALLATION PROCEDURES FOR SIMPSON DURA-VENT DIRECT VENT SYSTEM

5. Mark the wall with an 11" (279mm) x 10" (254mm) hole. See termination framing on page 20. The center of the hole should line up with the centerline of the horizontal pipe. Cut and frame the 11" (279mm) x 10" (254mm) hole in the exterior wall where the vent will be terminated. If the wall being penetrated is constructed of non-combustible material, (i.e. a masonry block, or concrete) a hole with zero clearance is acceptable. NOTES: The horizontal run of vent must be level, or have a 1/4" (6 mm) rise for every 12" (305 mm) of run towards the termination. Never allow the vent to run downward. This could cause high temperatures and may present the possibility of a fire. ALSO: The location of the horizontal vent termination on an exterior wall must meet local and national building codes, and must not be blocked or obstructed. For Allowable Termination Locations see page 12 in this manual.

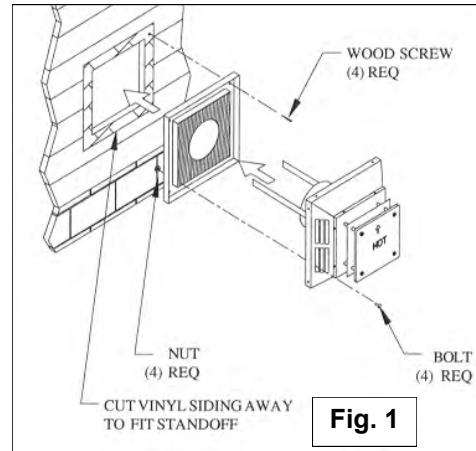

6. Position the Horizontal Vent Termination in the center of the square hole (arrow on the vent cap should be facing UP), and run a bead of non-hardening sealant around the outside edges of the termination, so as to make a seal between the termination and the wall. Finish attaching the termination cap to the wall with the four wood screws provided with the termination cap. NOTE: The four wood screws provided should be replaced with the appropriate fasteners for stucco, brick, concrete or other types of siding. For buildings with VINYL SIDING, a Vinyl Siding Standoff should be installed between the vent cap and the exterior wall. Attach the Vinyl Siding Standoff to the Horizontal Termination Cap by bolting the flat portion of the Vinyl Siding Standoff (Fig.1.) so that an air space will exist between the wall and the Vent Termination.

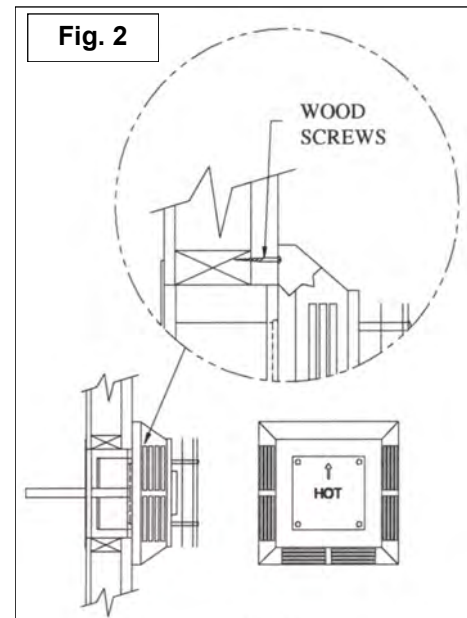

7. Locate and slide the Wall Thimble Cover over the vent pipe.
8. Slide the appliance and vent assembly towards the wall, carefully inserting the vent pipe into the vent cap assembly. It is important that the vent pipe extend into the vent cap sufficient distance so as to result in a minimum pipe overlap of 1-1/4" (31 mm). Secure the connection between the vent pipe and the vent cap by attaching the two sheet metal strips extending from the vent cap assembly into the outer wall of the vent pipe. Use the two sheet metal screws provided to connect the strips to the pipe section. Bend any remaining portion of the sheet metal strip back towards the vent cap, so it will be concealed by the Wall Thimble Cover. (Fig. 2.)

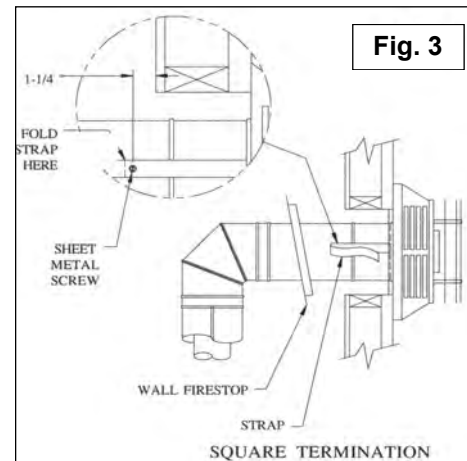

9. Slide the Wall Thimble Cover up to the wall surface and attach to the wall with wood screws. (Fig. 3.)

ELECTRICAL CONNECTIONS, FAN SYSTEM

WARNING: Before starting, make certain the power supply is turned OFF.

Have a qualified electrician run a 120VAC supply line to the lower left side of the fireplace before installing the appliance. There should be 18" (460mm) of the supply line free for ease of connection to the appliance. Connect the electrical supply line to the appliance at the same time the gas line is being connected to the appliance.

NOTE: This appliance, when installed, must be electrically grounded in accordance with local codes or, in the absence of local codes, with the **National Electrical Code, ANSI/NFPA 70**, or the **Canadian Electrical code, CSA C22.1**.

Open the bottom (louver) grill and undo the 2 screws holding the control panel. Run the line into the left side of the appliance through the hole in the rear of the junction box and hold with a standard 7/8" (22 mm) clamp. Connect the (black) supply conductor to the free black conductor from the speed controller with a marrette type wire connector. Connect the 'neutral' white supply conductor to the free white conductor from the fan with a marrette-type wire connector. Connect the 'ground' (green or bare) conductor to the ground screw in the junction box. Replace the junction box cover the control panel and fasten with the 2 screws. A BX connector or other suitable approved wiring strain relief must be installed on the junction box.

The fan may be operated by the remote control or by having a qualified electrician wire the fireplace to a thermostat. In thermostat mode the fan will start approximately 5 minutes after the fireplace is turned on and stop approximately 12 minutes after the burner shuts off.

WIRING DIAGRAM

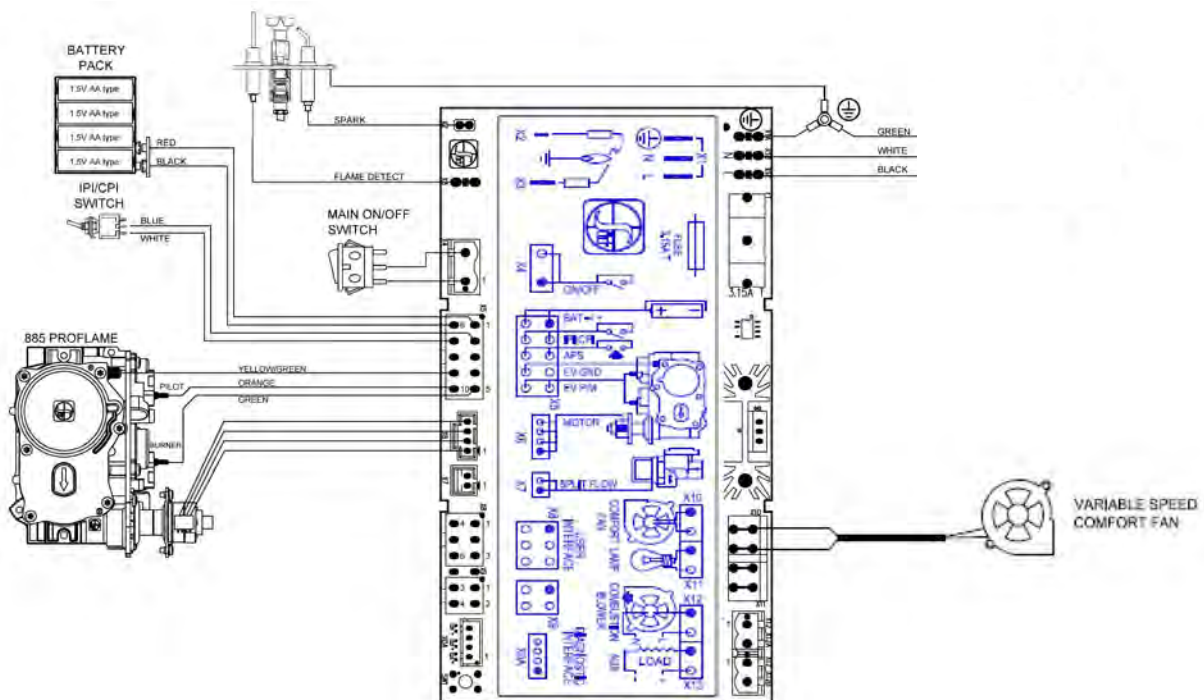

LOG PLACEMENT

The Archgard pan burner and fiber logs are designed to give a realistic fire package, and are created to look the same as the day they were originally installed. Care must be given when first installing the logs, and if removed for servicing, as they can be damaged or broken if not handled properly.

After opening the log set package, inspect the logs to ensure that no damage has occurred inside the package. Please report any damage immediately to your Authorized Archgard Dealer.

Gas and vent connections must be made before installing the logs and embers on the pan burner.

NOTE: Improper placement of logs and/or embers may cause sooting on the internal parts and glass, and will not be covered under warranty. Do not use broken or damaged logs.

WARNING: Failure to position the parts in accordance with these diagrams or failure to use only parts specifically approved with this appliance may result in property damage or personal injury.

The pan burner has pins and rests to accept the logs. Locate the grate and embers and place them on the pan burner as shown. Refer to the pictured instructions on the following pages that will show how to place the logs. The bottom of each log has a 1 or 4 digit code that can be used as a reference to help locate the correct log.

IMPORTANT: Pins & holes must be aligned with logs & burner.

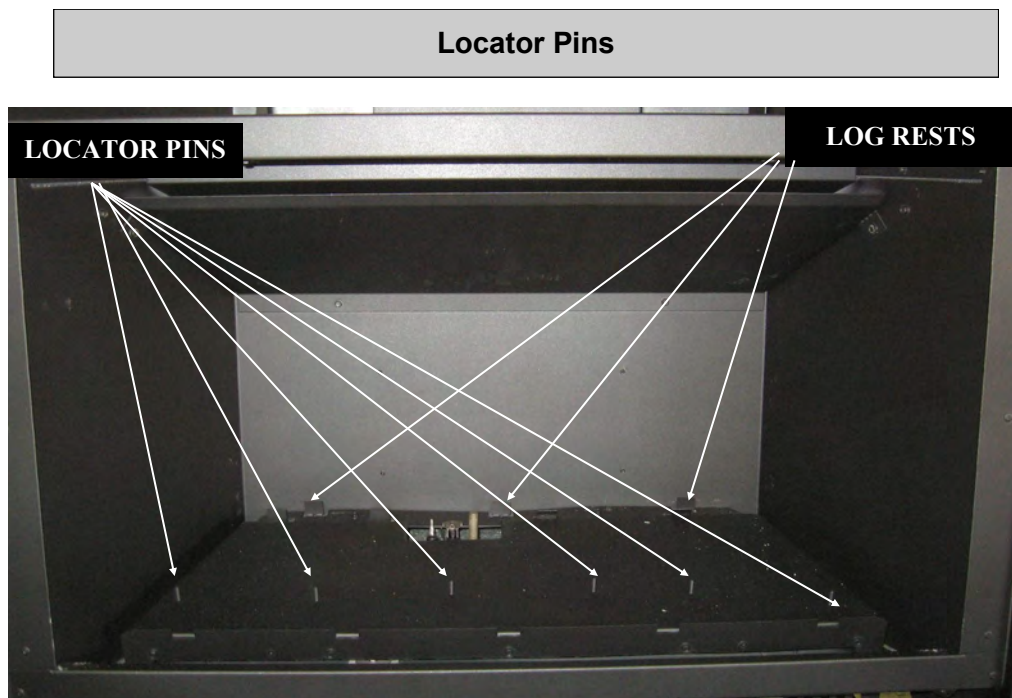

NOTE: Installing the fiber logs in any other position other than shown will result in flame impingement causing sooting of the logs, brick liner and ceramic glass viewing area.

LOG PLACEMENT... Continued

Step 1. Locate Log with 7207 stamped on the bottom and place it as shown.

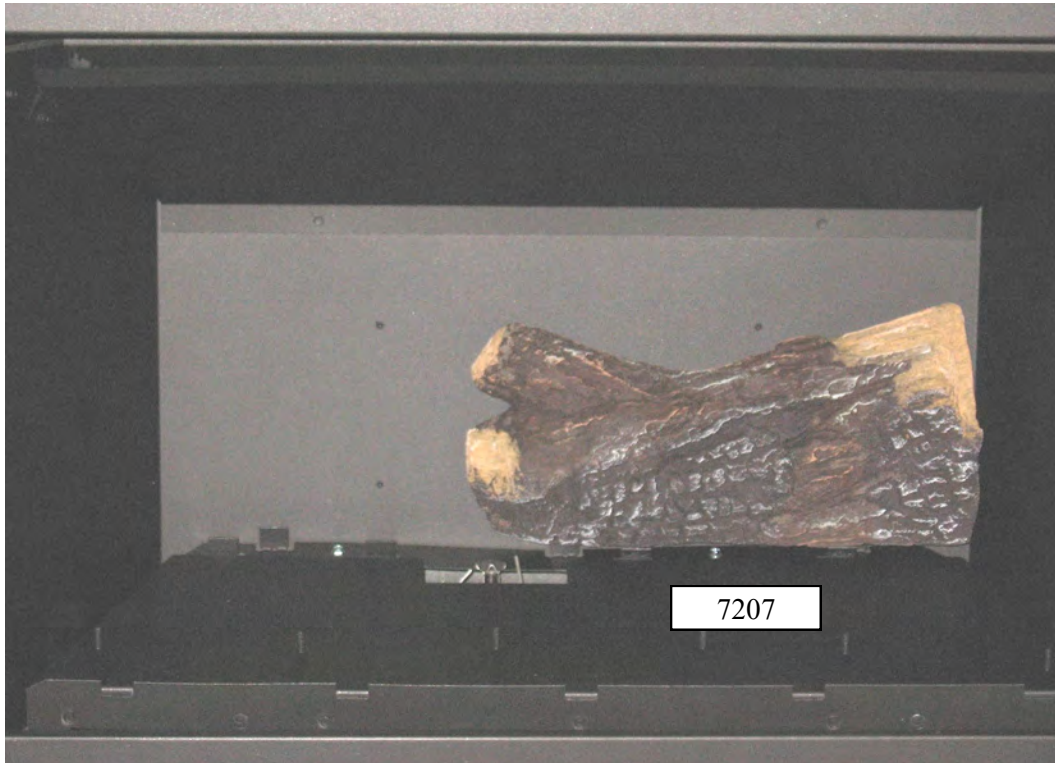

Step 2. Locate Log with 7201 stamped on the bottom and place it as shown.

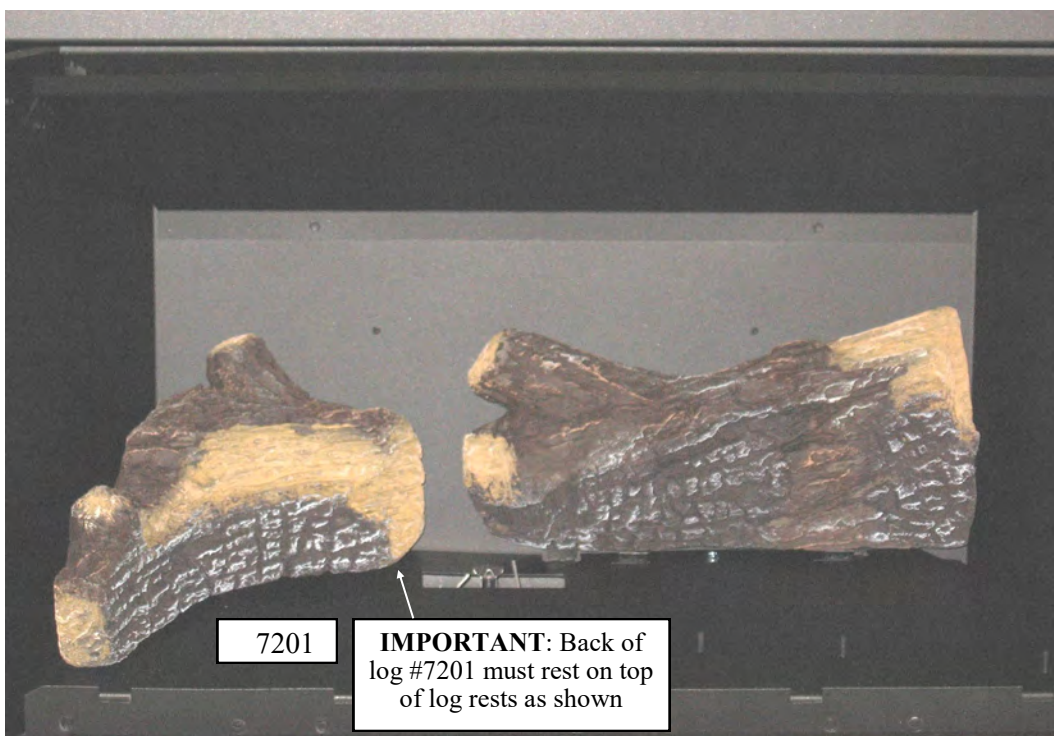

LOG PLACEMENT... Continued

Step 3. Locate Log with 7203 stamped on the bottom and place it at the rear as shown.



Step 4. Locate Log with 7202 stamped on the bottom and place it on the burner as shown.



LOG PLACEMENT... Continued

Step 5. Locate Log with 6 stamped on the bottom and place it on the front pins as shown.



Step 6. Locate Log with no number stamped on the bottom and place it as shown.

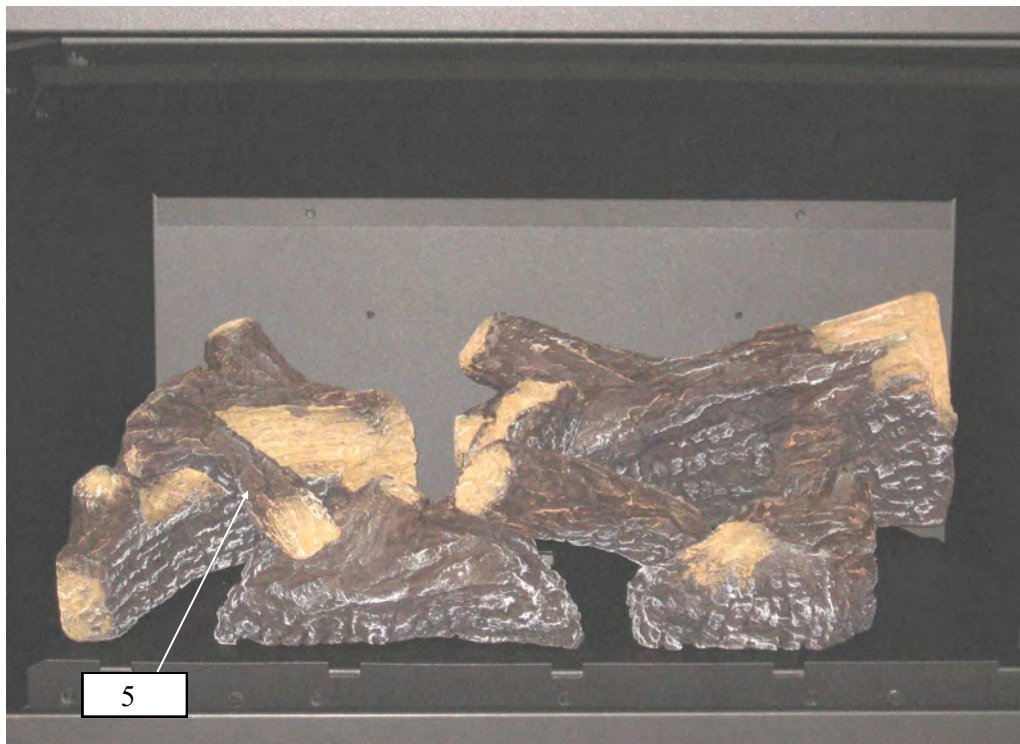

LOG PLACEMENT... Continued

Step 6. Locate Log with 7205 stamped on the bottom and place it on the front pins as shown.



Step 7. Place black embers around logs as shown , do not cover the holes in the burner.

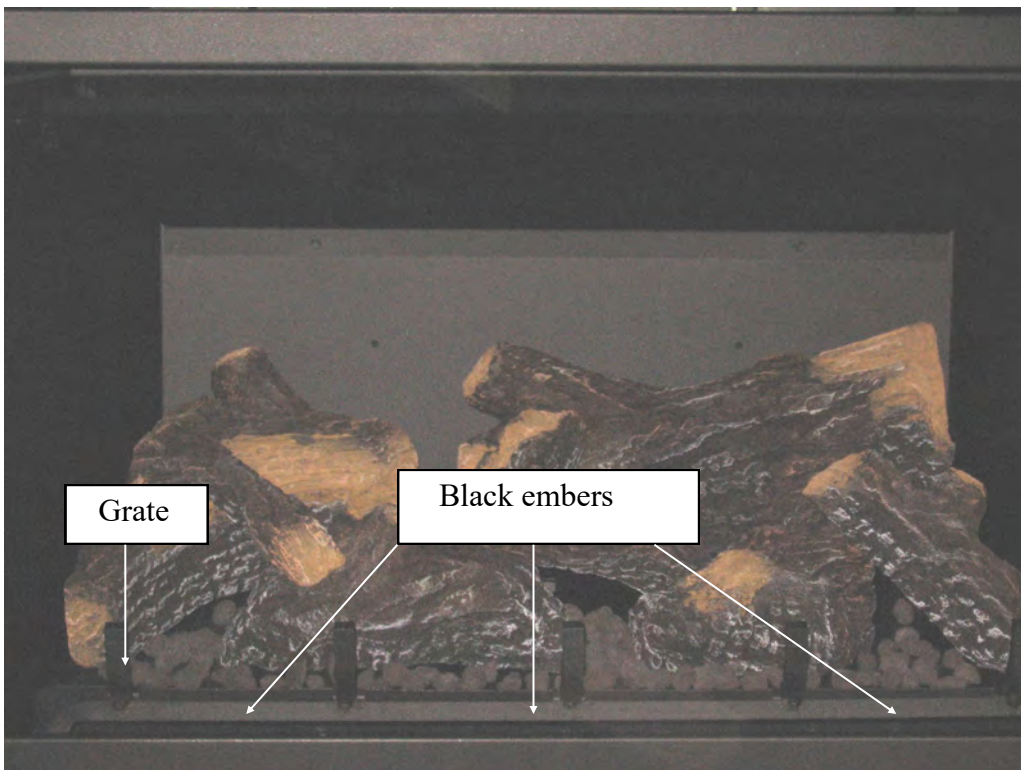

Step 8. Locate the grate and place it as shown.

OPTIONAL BRICK PLACEMENT

The Archgard brick panels offer a variety of looks to customize your fireplace and are purchased separately. Care must be given when first installing the bricks, and if removed for servicing, as they can be damaged or broken if not handled properly.

Gas and vent connections must be made before installing the brick and reflective panels.

NOTE: Improper placement of panels may cause sooting on the internal parts and glass, and will not be covered under warranty. Do not use broken or damaged logs.

The 72-DVTE30-2 has two different brick panel options, Quebec City Red and Quebec City Grey. The brick panel options come separate from the unit and must be installed inside of the unit once you have chosen your color option. If you find any damage to the Ceramic Brick Panels, please contact the Authorized Archgard Dealer where you purchased the unit to order replacements.

WARNING: Failure to position the parts in accordance with these diagrams or failure to use only parts specifically approved with this appliance may result in property damage or personal injury.

The fireplace has panel mounting brackets already in place. Remove the brackets before installing the panels. Locate the brick or reflective panels and place them in the firebox as shown. Refer to the pictured instructions on the following pages that will show how to place the panels.

Rear Brick Panel Placement as Shown

1st Panel



NOTE: Installing the panels in any other position other than shown will result in flame impingement causing sooting of the logs, brick liner and ceramic glass viewing area.

Right Brick Panel Placement as Shown

2nd Panel



3rd Panel

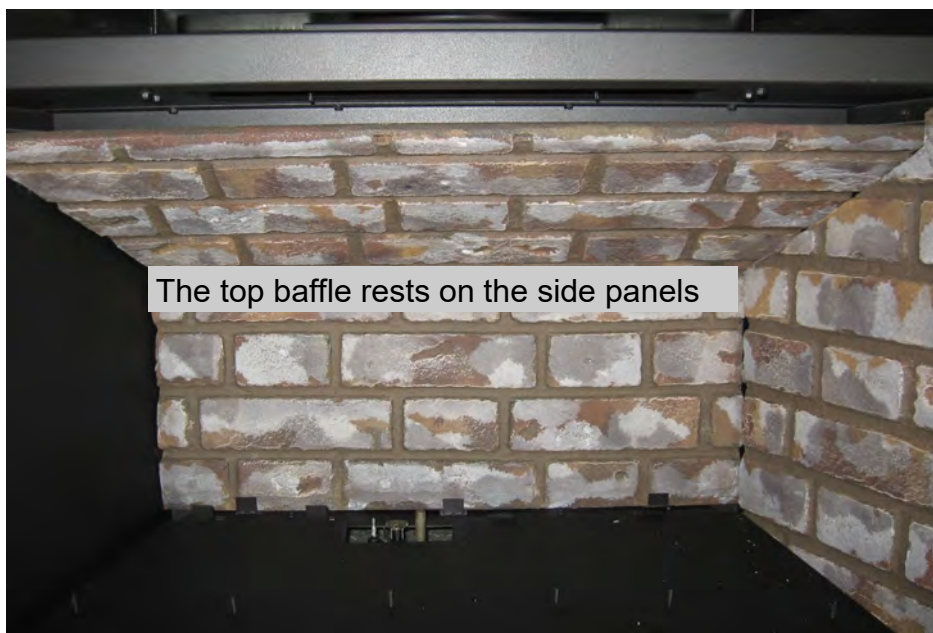

NOTE: Installing the panels in any other position other than shown will result in flame impingement causing sooting of the logs, brick liner and ceramic glass viewing area.

Left Brick Panel Placement as Shown

4th Panel



NOTE: Installing the panels in any other position other than shown will result in flame impingement causing sooting of the logs, brick liner and ceramic glass viewing area.

The following steps highlight the procedure for installing Reflective Ceramic Glass liner. This kit comes standard on the Optima 72 Eclipse edition and is available as an option for other models.

Gas and vent connections must be made before installing the brick and reflective panels.

We recommend using clean cotton gloves when handling panels. Handle the panels with care. Inspect the panels to ensure that no damage has occurred inside the package. Please report any damage immediately to your Authorized Archgard Dealer.

Before you begin:

- **Ensure the gas supply is turned OFF and disconnect the power supply (including backup batteries)**
- Remove barrier screen (see **Page 39**)
- Remove Glass Door (see **Page 38**)
- Remove Log Set (if installed, see **Page 26**)

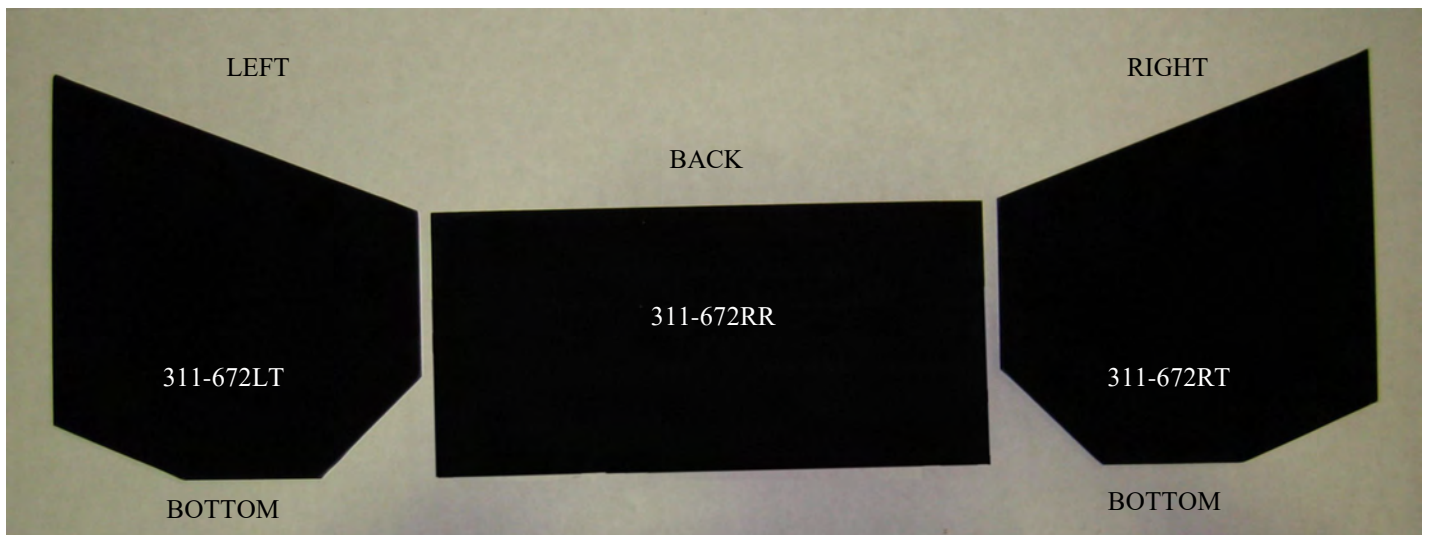

Step 01: Place rear panel against the back wall of the firebox and slide in behind tabs on burner tray.



Step 02: Place left side panel in the firebox along the side of the burner tray and secure with clip. (supplied in kit)



Step 03: Place right side panel in the firebox along the side of the burner. Secure side panel with a clip and screw (supplied in kit).



Step 04: Install logs and door to complete installation

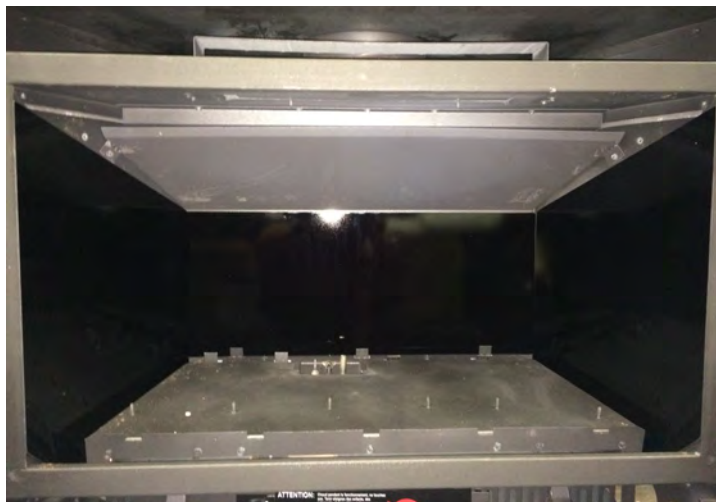

FIRST FIRE

When operated for the first few times, the appliance will emit some odor and fumes. This is due to the heat from the appliance evaporating the oils and solvents used in fabricating the appliance. Close off the room to the rest of the house and open all windows. Keep the room well ventilated as smoke alarm may sound. Run the appliance for at least 6 hours at maximum setting with blower set to "OFF" to allow paint to cure (after the installer has checked to ensure the fan is operational). Smoke and fumes caused by the curing process may cause discomfort to some individuals.

LIGHTING INSTRUCTIONS - CAUTION

WARNING : If you do not follow these instructions exactly, a fire or explosion may result causing property damage, personal injury or loss of life. Do not operate the appliance with the glass front removed, cracked or broken. Replacement of broken glass should be done by a licensed or qualified service person.

1. **BEFORE LIGHTING**, smell all around the appliance area for gas. Be sure to smell next to the floor, because some gasses are heavier than air and will settle on the floor.
2. **IF YOU SMELL GAS**, follow the instructions as listed directly above or as shown on the front cover of this manual.
3. Do not use this appliance if any part has been under water. Immediately call a qualified service technician to inspect the appliance and to replace any part of the control system and any gas control which has been under water.
4. This appliance is equipped with an ignition device which automatically lights the pilot and main burner. The pilot and burner light automatically with the hand held remote or with the switch behind the louvers if it is activated.

FINAL INSTALLATION CHECK

Each Archgard Gas Fireplace is checked and tested at the factory prior to being packaged, shipped to our dealers, and finally installed in your home. Archgard recommends that, before leaving this unit with the customer, the installer must ensure that the appliance is firing correctly, and that the electrical system is in working order. **This will include:**

1. Performing leak tests of supply line, gas control valve, supply line from gas control valve and pilot assembly.
2. Clocking the appliance to ensure the correct firing rate (see rating plate or page 6 of this manual).
3. If required, adjusting the primary air to burner to ensure that the flame does not carbon or soot. (see rating plate or page 6 of this manual)
4. Check for proper operation including correct drafting.
5. The FAN system should be turned ON for a minimum of 15 minutes to ensure the fan, rheostat and fan sensor are all working correctly. After the system has been checked, and confirmed that the fan components are in working order, turn the fan system OFF and refer to the instructions for FIRST FIRE located in this manual.

Any alteration to the product that causes carboning or sooting that results in any damage or requires cleaning is not the responsibility of the manufacturer.

INITIAL OPERATION

1. Check that the appliance is properly vented and connected to the gas supply.
2. Check that the logs and branches are properly placed.
3. Check that all external parts, such as grills, door and faceplate are properly attached and fastened.
4. Do not operate this appliance with broken or cracked glass doors or without the door (s) in its correct (and latched) position. Do not use abuse the glass by either striking or slamming shut.
5. Check that there are no fingerprints left on gold surfaces or glass panels, as high temperature can bake these prints on permanently.

LIGHTING INSTRUCTIONS ON RATING PLATE

FOR YOUR SAFETY READ BEFORE LIGHTING
POUR VOTRE SÉCURITÉ VEUILLEZ LIRE AVANT L'ALLUMAGE

WARNING: If you do not follow these instructions exactly, a fire or explosion may result causing property damage, personal injury or loss of life.

AVERTISSEMENT: Quiconque ne respecte pas à la lettre les instructions dans la présente notice risque de déclencher un incendie ou une explosion entraînant des dommages, des blessures ou la mort.

- A. This appliance is equipped with an ignition device which automatically lights the pilot. Do not try to light the pilot by hand. When lighting the pilot follow these instructions exactly.
- B. BEFORE OPERATING smell all around the appliance area for gas. Be sure to smell next to the floor because some gas is heavier than air and will settle on the floor.
- WHAT TO DO IF YOU SMELL GAS
- Do not try to light any appliance.
 - Do not touch any electrical switch; do not use any phone in your building.
 - Immediately call your gas supplier from a neighbor's phone. Follow the gas supplier's instructions
 - If you cannot reach your gas supplier, call the fire department.
- C. Do not use this appliance if any part has been under water. Immediately call a qualified service technician to inspect the appliance and to replace any part of the control system and any gas control which has been under water.
- A. Cet appareil est équipé d'un dispositif d'allumage qui allume automatiquement la veilleuse. N'essayez pas d'allumer la veilleuse à la main. Respectez les instructions ci-dessous à la lettre.
- B. AVANT D'ALLUMER la veilleuse, reniflez tout autour de l'appareil pour déceler une odeur de gaz. Reniflez près du plancher, car certains gaz sont plus lourds que l'air et peuvent s'accumuler au niveau du sol.
- QUE FAIRE SI VOUS SENTEZ UNE ODEUR DE GAZ:
- Ne pas tenter d'allumer d'appareil
 - Ne touchez à aucun interrupteur; ne pas vous servir des téléphones se trouvant dans le bâtiment
 - Appelez immédiatement votre fournisseur de gaz depuis un voisin. Suivez les instructions du fournisseur.
 - Si vous ne pouvez rejoindre le fournisseur de gaz, appelez le service des incendies.
- C. N'utilisez pas cet appareil s'il a été plongé dans l'eau, même partiellement. Faites inspecter l'appareil par un technicien qualifié et remplacez toute partie du système de contrôle et toute commande qui ont été longés dans l'eau.

LIGHTING INSTRUCTIONS INSTRUCTION D'ALLUMAGE

1. STOP! Read the safety information above on this label. This appliance is equipped with an ignition device which automatically lights the pilot. Do not try to light the pilot by hand.
 2. Set the remote control switch to "OFF".
 3. Open the lower louvers, or remove trim and barrier screen.
 4. Turn off all electric power to the appliance.
 5. Open the gas isolation valve.
 6. Wait 5 minutes to clear out any gas. Then smell for gas, including near the floor. If you smell gas, STOP! and follow "B" in the safety information above (and to the left) on this label. If you do not smell gas, go to the next step.
 7. Turn on all electric power to the appliance.
 8. Set the remote control switch to "ON".
 9. If the fireplace does not light, the system will cycle through two trials (one minute of audible clicking, thirty seconds of silence, and then another one minute of audible clicking). If the system locks out due to inadequate gas flow, refer to troubleshooting in instruction manual.
 10. If the system will not function correctly, follow the instructions "To turn Off Gas To Appliance" below and call your service technician or gas supplier.
 11. Replace louver or trim.
1. ARRÊTEZ! Lisez les instructions de sécurité sur la portion supérieure (à droite) de cette étiquette. Cet appareil est équipé d'un dispositif d'allumage qui allume automatiquement la veilleuse. N'essayez pas d'allumer la veilleuse à la main.
 2. Réglez le commutateur à distance sur "OFF".
 3. Ouvrez persiennes inférieurs ou garnir.
 4. Coupez l'alimentation électrique de l'appareil.
 5. Vanne d'isolement de gaz ouverte.
 6. Attendez cinq (5) minutes pour laisser échapper tout le gaz. Reniflez tout autour de l'appareil, y compris près du plancher, pour déceler un odeur de gaz. Si vous sentez une odeur de gaz, ARRÊTEZ! Passez à l'étape B des instructions de sécurité sur la portion supérieure (à gauche) de cette étiquette. S'il n'y a pas d'odeur de gaz, passez à l'étape suivante.
 7. Réglez le commutateur à distance sur "ON".
 8. Allumez l'alimentation électrique de l'appareil.
 9. Si le foyer ne se allume pas, le cycle de la volonté du système grâce à deux essais (une minute de clic audible, trente secondes de silence, et puis un autre une minute de clic audible). Si le système se bloque en raison de l'écoulement de gaz insuffisante, voir le dépannage dans le manuel d'instruction.
 10. Si le système ne fonctionne pas correctement, suivez les instructions «Pour couper le gaz de l'appareil» ci-dessous et appelez votre technicien d'entretien ou fournisseur de gaz.
 11. Persienne fermée ou garnir.

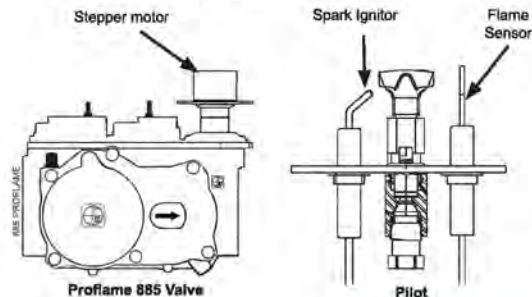
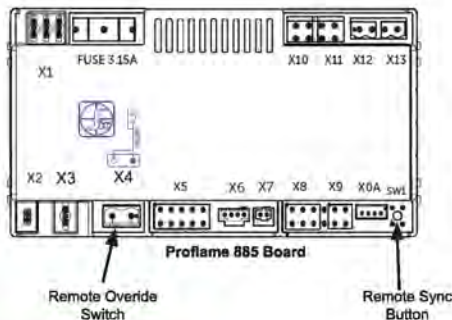

TO TURN OFF GAS TO APPLIANCE POUR COUPER LE GAZ À L'APPAREIL

1. Set the remote control switch to "OFF".
 2. Turn off all electric power to the appliance if service is to be performed.
 3. Open louver or access panel.
 4. Turn incoming gas isolation valve to "OFF" position.
 5. Close louver or trim.
1. Réglez le commutateur à distance sur "OFF".
 2. Coupez l'alimentation électrique de l'appareil s'il faut procéder à l'entretien.
 3. Ouvrez persiennes inférieurs ou porte d'accès.
 4. vanne d'isolement de gaz à proximité
 5. Persienne fermée ou garnir.

GLASS DOOR REMOVAL

WARNING: Do not operate appliance with the glass front removed, cracked or broken. Replacement of the glass should be done by a licensed or qualified service person. Do not abuse the glass doors, such as striking or slamming shut.

WARNING: Do not attempt to remove the glass door when the appliance is hot.

1. Remove the top louver by pulling the entire louver assembly towards you.
2. Open bottom hinged louver .
3. Locate the 2 buckle latches under the door frame (Fig.1) and pull down the lever on the back of the latches to release them.
4. Unhook the latches from the bottom of the door and swing the bottom of the door towards you then lift up on the whole door to unhook the top of door. Carefully remove the door and put it away at a safe location where it cannot be scratched or damaged.

Replacing the Glass Door

Reverse the above procedure.

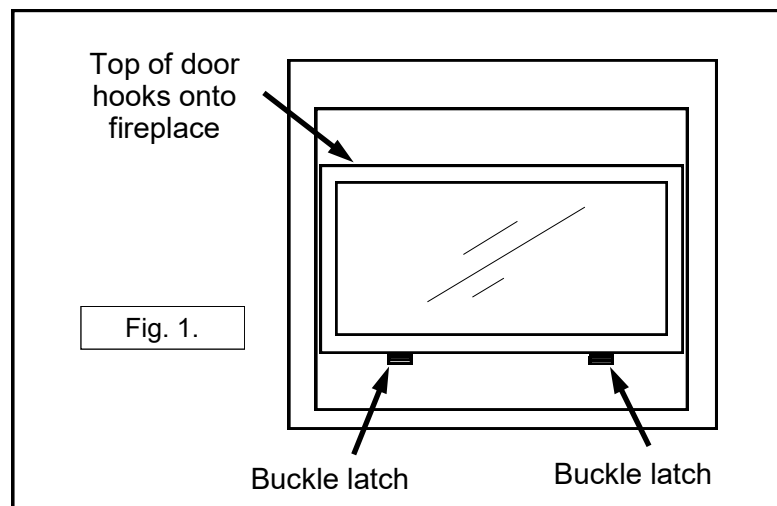

IF YOUR GLASS BREAKS

In the event your glass cracks or breaks, Archgard recommends that a new door assembly be ordered to replace the original door.

- Remove door as per the instructions above.
- Replace with new door assemblies.

NOTE: the NEW door will omit some odor when the appliance is re-lit and the odor will dissipate after the gasket material within the door has cured.

WARNING: Do not substitute any glazing material types.

LOUVER (UPPER & LOWER GRILLS) INSTALLATION

The Optima 72 is packaged without the upper and lower louvers (grills). They must be ordered separately. This is to allow you the option of black, black/gold, black/pewter louvers or all gold louvers.

After opening the louver package, inspect the upper and lower louvers to ensure that no damage has occurred inside the package. Please report any damage immediately to your Authorized Dealer.

Upper Louver installation.

1. Locate the Upper Louver. (Fig. 1)
2. Ensure the glass door is on the appliance.
3. Place the louver in the two catches located at the side of the appliance.

Lower Louver installation.

1. Locate the Lower Louver. (Fig. 1)
2. Locate the Hinges on the Lower Louver. (Fig. 2)
3. Locate the pre-drilled holes on the appliance. (Fig. 3)
4. Line up the hinges (on the louvers) and on the appliance and fasten the louvers with the 4 screws provide in the louver package. (Fig. 4)

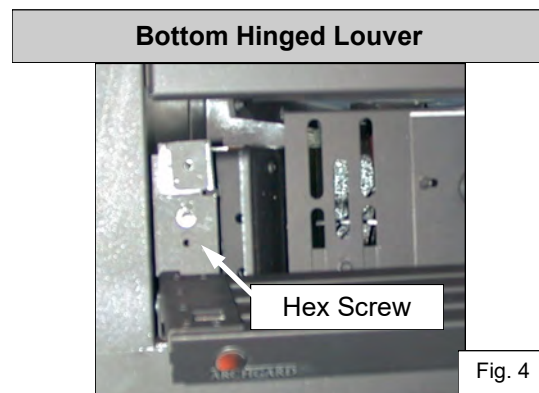
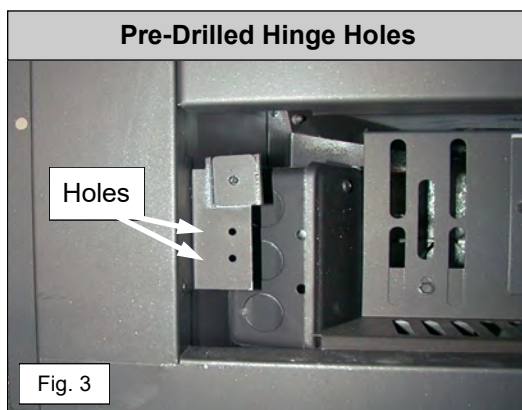
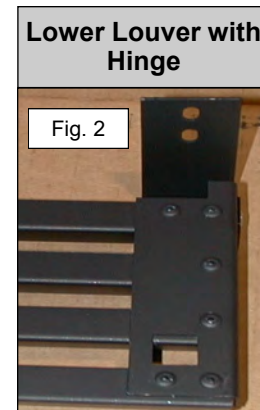
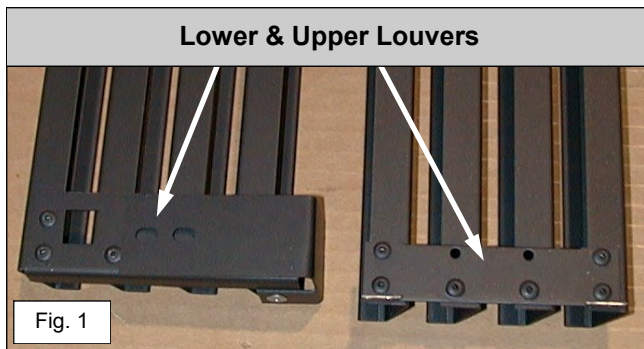

CAUTION:

Only Trim kit (s) supplied by the manufacturer may be used in the installation of this appliance.

BARRIER SCREEN INSTALLATION AND REMOVAL

If barrier becomes damaged, the barrier shall be replaced with the manufacturer's barrier for this appliance (Part Number: 72-BS)

Note: The Optima 72 Eclipse (model #: 72-DVTE30N-2-ERG or 72-DVTE30P-2-ERG) does NOT include the 72-BS Barrier Screen as the screen is part of the Eclipse front.

- REMOVE TOP AND BOTTOM LOUVERS (OR OPTIONAL FRONT)
- UNHOOK BOTTOM DOOR LATCHES
- PLACE SAFETY BARRIER OVER DOOR FRAME.

- CONFIRM SAFETY BARRIER TABS ARE SEATED ON TOP OF THE DOOR FRAME.

- PUSH IN BOTTOM OF SCREEN AND DOOR.
- RELATCH BOTTOM DOOR LATCHES

Safety Barrier installed.

- To remove screen, reverse installation process.

WARNING

DOOR MUST BE INSTALLED PRIOR TO SCREEN INSTALLATION TO AVOID POSSIBLE DAMAGE OR INJURY.



ECLIPSE FRONT INSTALLATION & REMOVAL

The Archgard Optima 72 Eclipse (model #: 72-DVTE30N-2-ERG or 72-DVTE30P-2-ERG) comes standard with the Eclipse front and Eternal Flame Reflective Ceramic Glass panel set. The following steps show how to install the front. See Page 34 for information on how to install the panel set.

Note: These models do not include the barrier screen (72-BS). The Eclipse front is also compatible with the 72-DVTE30N-2 and 72-DVTE30P-2).

The mounting plate for the Eclipse front is installed at the factory using two tek screws on the top and two on the bottom.

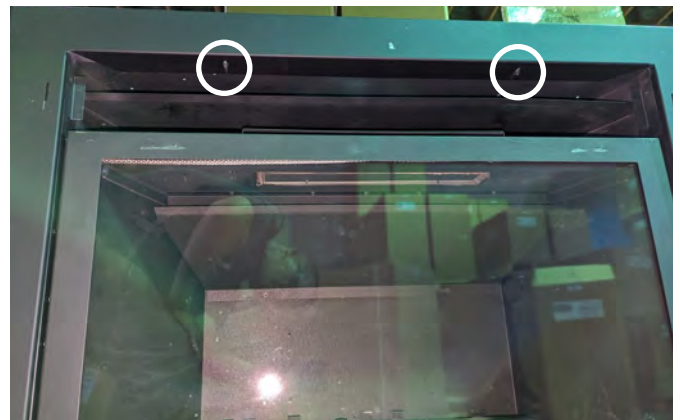

The upper and lower louvers are packed with the fireplace. The upper louver hooks over tabs located above the door. The lower louver hooks over the magnet bracket under the door.

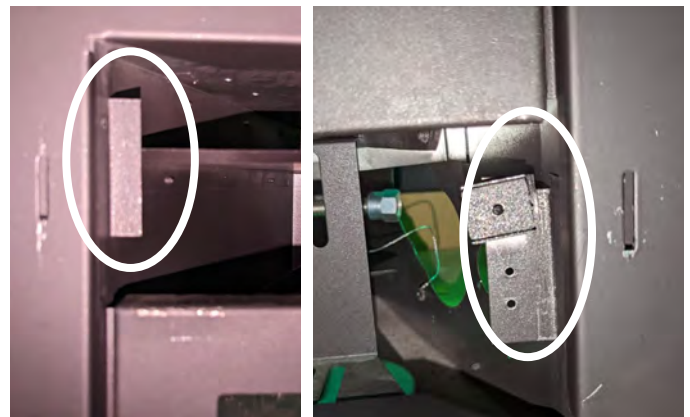
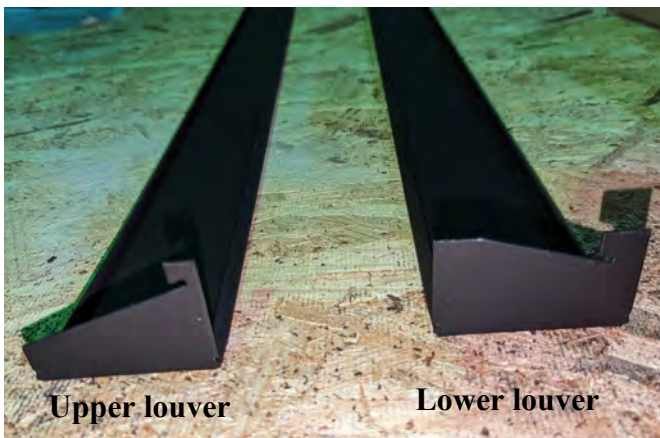

Install the upper and lower louvers.



The front door hooks onto the mounting plate using hooks on each corner.



Hook the front door onto the mounting plate.



Removal is the reverse of installation.

ECLIPSE FRONT FIT AND FINISHING

The Eclipse front is adjustable up to 7/8" from the face of the fireplace. This will allow you to install non-combustible finish material behind the front for a cleaner finish.

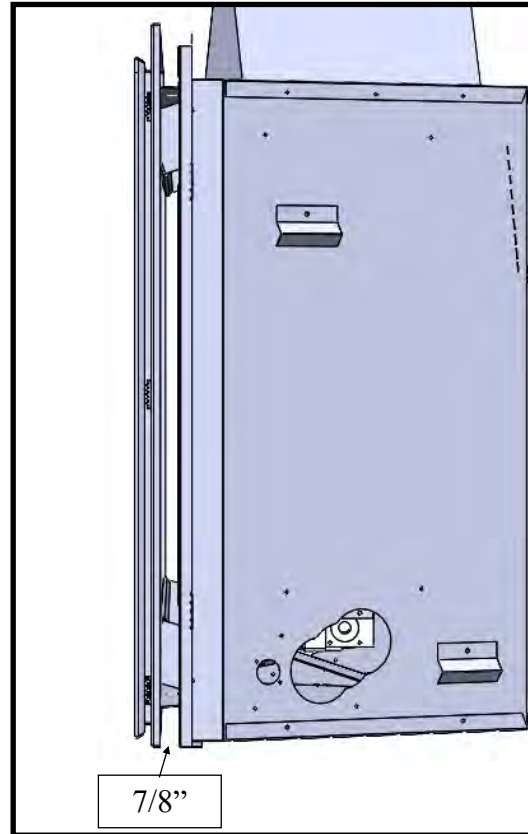
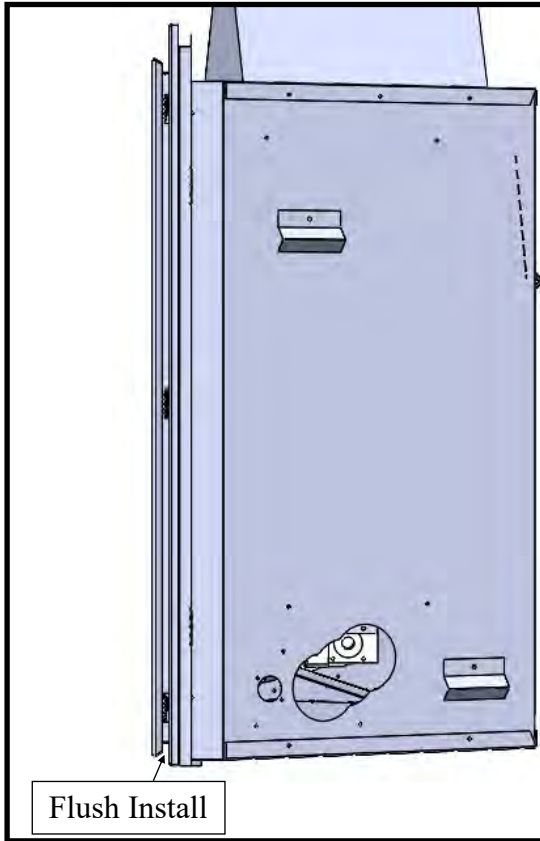

The bottom of the Eclipse has a 1/2" clearance from the bottom of the fireplace.

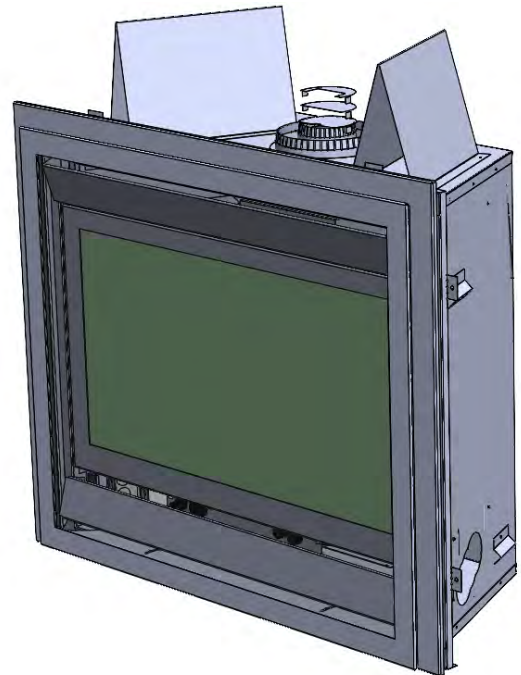
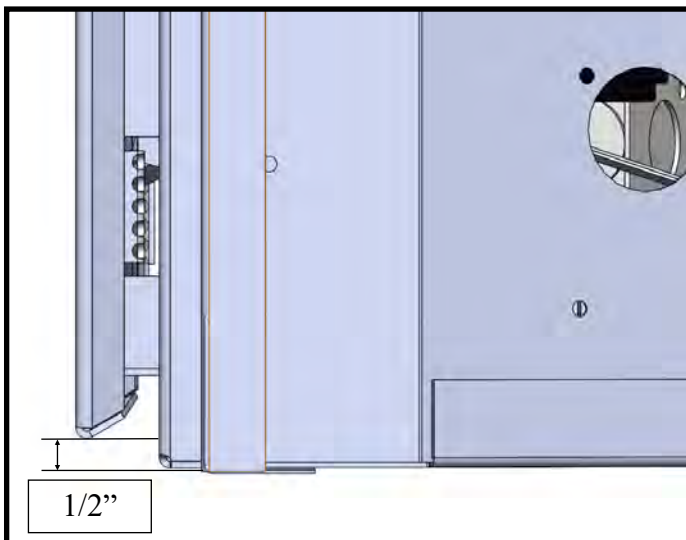

DYNAMIC START ADVANTAGE

This fireplace comes standard with the Dynamic Start Advantage. This new electronic ignition system is the latest in fireplace technology. It helps to create a better draft, better flame appearance, less condensation on the glass, and years of carefree operation.

How the system works:

When starting a solid fuel wood burning fireplace you build a fire. You start with a little bit of tinder and kindling to create small fire, and then work your way up to larger logs once a draft has been established. Dynamic Start uses the same principle. When you press the "ON" button on the remote control the main burner will light and remain with a low flame for two minutes. This will first establish a draft in the vent and slowly warm up the fireplace. When two minutes have passed, the main burner will automatically ramp up to the high flame (or whichever setting you have established on the remote control).

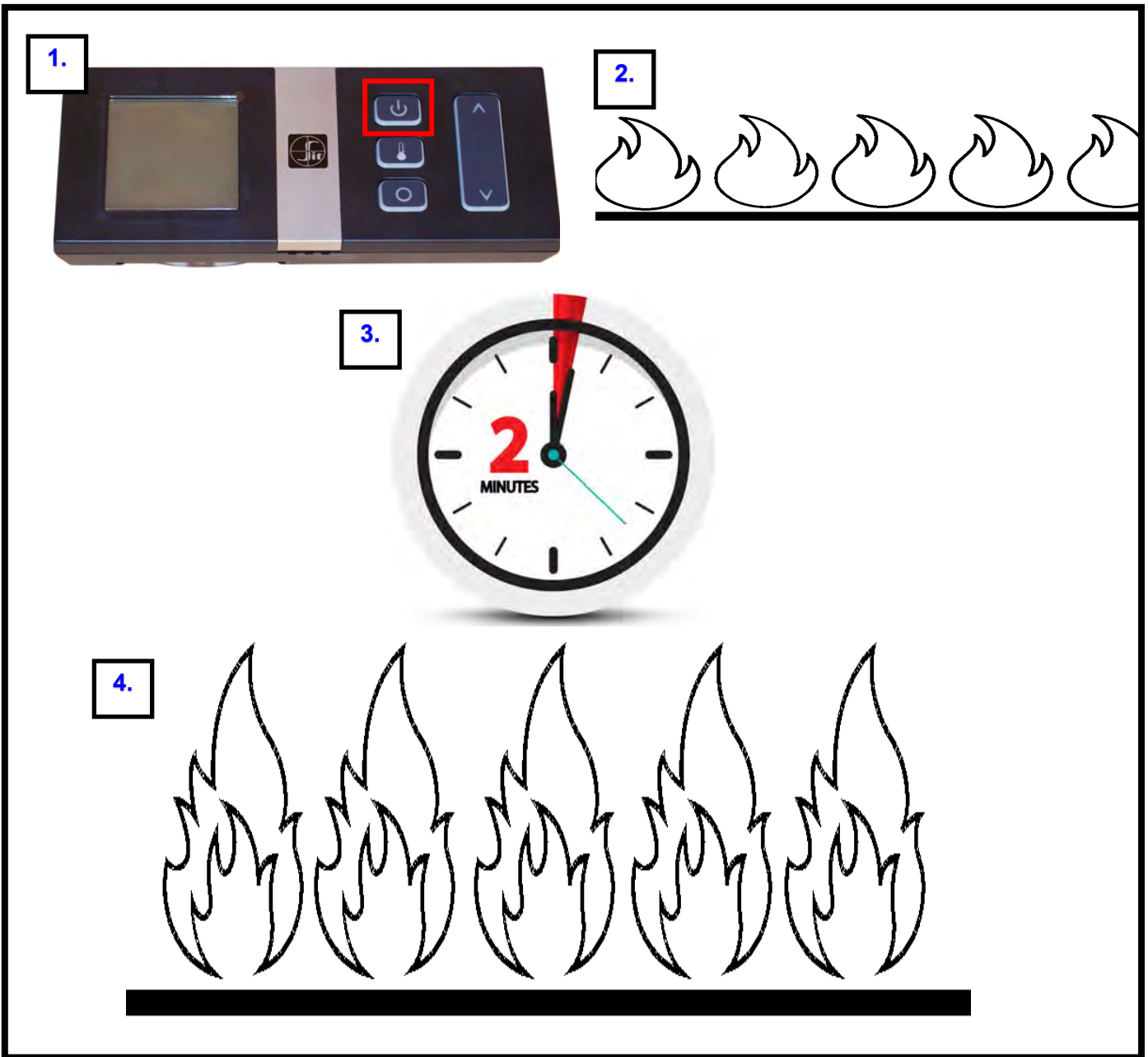

REMOTE CONTROL SETUP AND OPERATION

IMPORTANT

The Proflame Transmitter 2 is an integrated part of the Proflame 2 System, which consists of these elements:

- Proflame 2 Transmitter, to be used in conjunction with:
- Integrated Fireplaces Control (Proflame 2 IFC)

The Proflame 2 Transmitter provides for controlling the following hearth appliance functions:

1. Main Burner On/Off
2. Main Burner flame modulation (6 levels)
3. Choice of standing or intermittent pilot (CPI/IPI)
4. Thermostat and Smart thermostat functions
5. Accent light modulation (6 levels)
6. Split flow valve
7. On/Off relay
8. Comfort Fan speed modulation (6 levels)

The Proflame Transmitter uses a streamline design with a simple button layout and informative LCD display (Fig. 1). A Mode Key is provided to index between the features and a Thermostat Key is used to turn on/off or index through Thermostat functions (Fig. 1 & 2). Additionally, a Key Lock feature is provided (Fig. 22).

SIMPLE INSTALLATION



Optional handheld remote



REMOTE CONTROL SETUP AND OPERATION, cont.

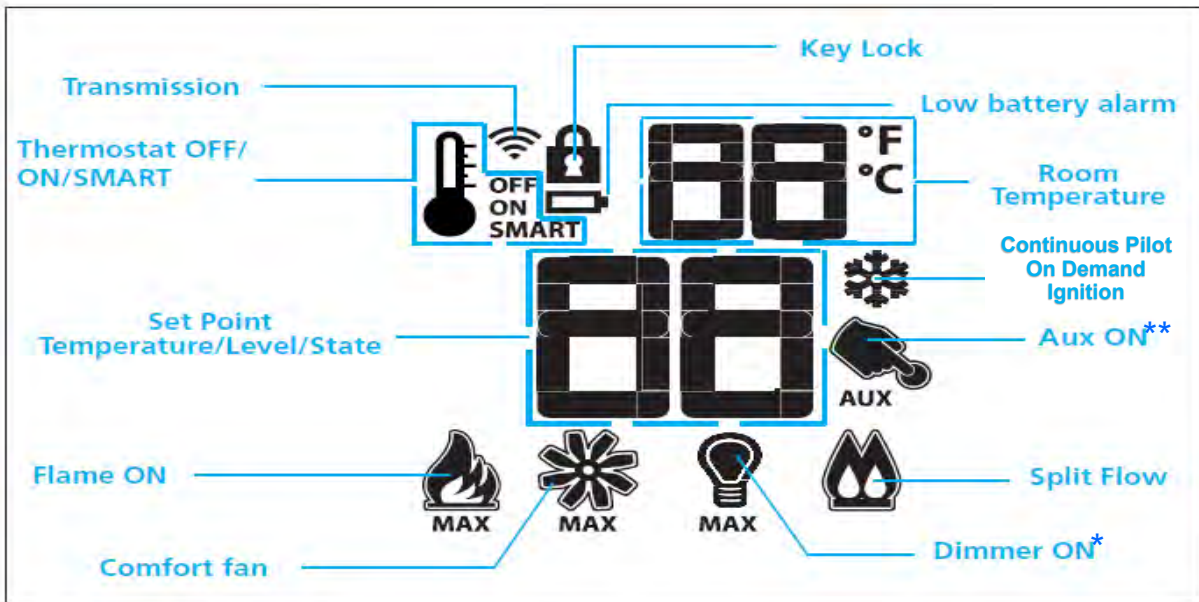

Fig. 2: Transmitter LCD display.

* Future Option
 ** Future release

TECHNICAL DATA

Remote Control	
Supply voltage	4.5 V (three 1.5 V AAA batteries)
Ambient temperature ratings	0 - 50 °C (32 - 122 °F)
Radio frequency	315 MHz

WARNING

THE TRANSMITTER AND RECEIVER ARE RADIO FREQUENCY DEVICES. PLACING THE RECEIVER IN OR NEAR METAL MAY SEVERELY REDUCE THE SIGNAL RANGE.

ATTENTION

TURN OFF THE MAIN GAS SUPPLY DURING INSTALLATION OR MAINTENANCE OF THE RECEIVER DEVICE
 TURN OFF MAIN GAS SUPPLY TO THE APPLIANCE PRIOR TO REMOVING OR REINSERTING THE BATTERIES
 IN CASE OF REMOTE CONTROL MALFUNCTION TURN OFF THE FIREPLACE BY REMOVING POWER SUPPLY (INCLUDING BACKUP BATTERIES)
 FOR INSTALLATION/MAINTENANCE SWITCH OFF THE FIREPLACE BY REMOVING POWER SUPPLY (INCLUDING BACKUP BATTERIES)

REMOTE CONTROL SETUP AND OPERATION, cont.

OPERATING PROCEDURE

Initializing the System for the first time

Power the receiver. Activate the procedure of the receiver address programming, see the receiver instruction (*). The Receiver will "beep" three (3) times to indicate that it is ready to synchronize with a Transmitter. Install the 3 AAA type batteries in the Transmitter battery bay, located on the base of the Transmitter. (fig. 3) With the batteries already installed in the Transmitter, push the On button. The Receiver will "beep" four times to indicate the Transmitter's command is accepted and sets to the particular code of that Transmitter. The system is now initialized.

(*) The receiver may be independent or integral to the IFC hearth appliance control module. The receiver instruction may not be independent when part of the IFC.



Fig. 3: Battery compartment.

Temperature indication Display

With the system in the "OFF" position, press the Thermostat Key and the Mode Key at the same time. Look at the LCD screen on the Transmitter to verify that a C or F is visible to the right of the Room Temperature display. (Fig. 4 and fig. 5)



Fig. 4: Remote Control display in Farenheit.



Fig. 5: Remote Control display in Celsius.

Turn on the Appliance

With the system OFF, press the ON/OFF Key on the Transmitter. The Transmitter display will show some other active Icons on the screen. At the same time the Receiver wil activate the appliance. A single "beep" from the Receiver will confirm reception of the command.

Turn off the Appliance

With the system ON, press the ON/OFF Key on the Transmitter. The Transmitter LCD display will only show the room temperature (Fig. 6). At the same time the Receiver will turn off the appliance. A single "beep" from the Receiver confirms reception of the command.



Fig. 6: Remote Control display.

REMOTE CONTROL SETUP AND OPERATION, cont.

Remote-Flame Control

The proflame has six (6) flame levels. With the system on, and the flame level at the maximum in the appliance, pressing the Down Arrow Key once will reduce the flame height by one step until the flame is turned off.

The Up Arrow Key will increase the flame height each time it is pressed. If the Up Arrow Key is pressed while the system is on but the flame is off, the flame will come on in the high position. (Fig. 7 & 8) A single "beep" will confirm reception of the command.



Fig. 7: Flame Off

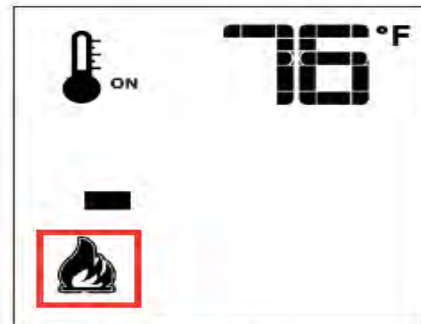

Flame Level 1

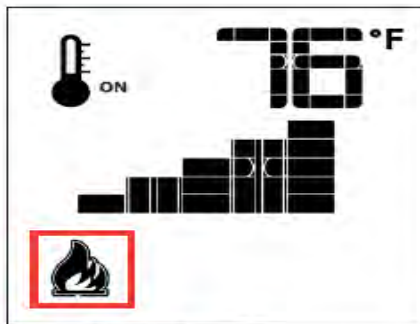

Fig. 8: Flame level 5



Flame Level Maximum

Room Thermostat (Transmitter Operation)

The Remote Control can operate as a room thermostat. The thermostat can be set to a desired temperature to control the comfort level in a room.

To activate this function, press the Thermostat Key (Fig. 1). The LCD display on the Transmitter will change to show that the room thermostat is "ON" and the set temperature is now displayed (Fig. 9). To adjust the set temperature, press the Up or Down Arrow Keys until the desired set temperature is displayed on the LCD screen of the Transmitter.

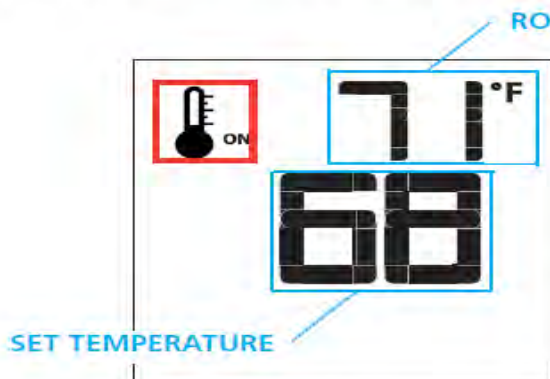

Fig. 9

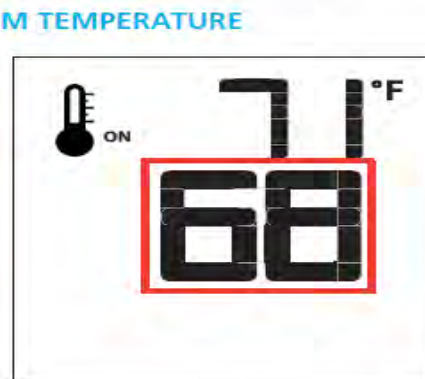

Fig. 10

REMOTE CONTROL SETUP AND OPERATION, cont.

Smart Thermostat (Transmitter Operation)

The Smart Thermostat function adjusts the flame height in accordance to the difference between the set point temperature and the actual room temperatures. As the room temperature gets closer to the set point the Smart Function will modulate the flame down.

To activate this function, press the Thermostat Key (Fig. 1) until the word "SMART" appears to the right of the temperature bulb graphic (Fig. 11).

To adjust the set temperature, press the Up or Down Arrow Keys until the desired set temperature is displayed on the LCD screen of the Transmitter (Fig. 12).

Note. When Smart Thermostat is activated, manual flame height adjustment is disabled.

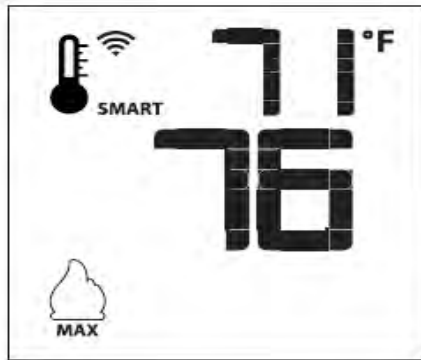

Fig. 11: Smart flame function

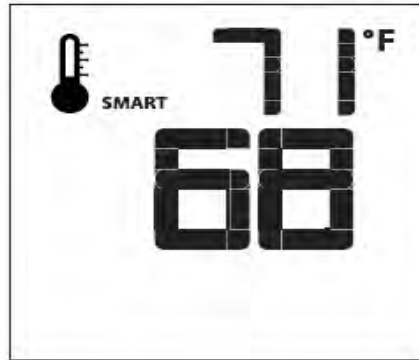

Fig. 12

Split Flow control (Not available on all units)

The secondary burner is controlled by the split Flow. To activate this function use the Mode Key (fig. 1) to index to the SPLIT FLOW mode icon (fig. 19 & 20).

Pressing the Up Arrow Key will activate the secondary burner. Pressing the Down Arrow Key will turn the secondary burner off. A single "beep" will confirm the reception of the command.



Fig. 19

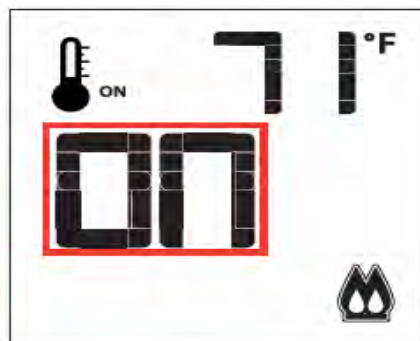
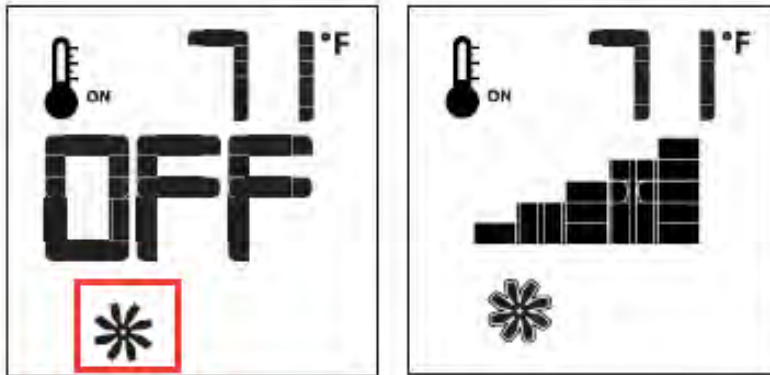

Fig. 20

REMOTE CONTROL SETUP AND OPERATION, cont.

Fan Speed Control

If the appliance is equipped with a hot air circulating fan, the speed of the fan can be controlled by the Proflame system. The fan speed can be adjusted through six (6) speeds. To activate this function use the Mode Key (fig.1) to index to the fan control icon (Fig. 13). Use the Up/Down Arrow Keys (Fig.1) to turn on, off or adjust the fan speed (fig. 14). A single "beep" will confirm reception of the command.



Continuous Pilot on Demand / Intermittent Pilot (CPI/IPI) Selection

With the system in "OFF" position press the Mode Key to index to the CPI mode icon. Pressing the UP Arrow Key will activate the Continuous Pilot on Demand Ignition mode (CPI). Pressing the Down Arrow Key will return to IPI. A single "beep" will confirm the reception of the command.

CPI vs IPI:

Continuous Pilot on Demand Ignition (CPI): In this mode the pilot runs continuously even when the main burner is off. The Continuous Pilot on Demand Ignition operates on a seven day cycle. If the main burner is not turned on for seven continuous days, the pilot will turn itself off. When the main burner is lit again the cycle repeats. The pilot will remain lit for seven days, even after the main burner is turned off. If the main burner is lit during a seven day timing cycle, the seven day timer will reset.

Intermittent Pilot Ignition (IPI): A fuel saving mode in which the pilot is only used when the main burner is on. This appliance is shipped in IPI mode. IPI mode is often the preferred method, however, there are some situations where it may be preferable to switch the fireplace into CPI mode. For example, in colder climates the glass door or the front of the fireplace could become very cold to the touch. Dynamic Start Advantage will solve most problems experienced by older IPI operated fireplaces.



MAINTENANCE**CAUTION:**

Do not conduct maintenance on the appliance while it is operating or while it is still hot. Always verify proper operation after servicing.

Cleaning and Routine Maintenance

The exterior painted surfaces, glass, and metal plated trims may be cleaned with a soft, non-abrasive cloth and water or a suitable, mild, non-abrasive cleaner. Be sure there are no fingerprints left on the glass panels as high temperatures can bake these prints on permanently.

Regularly:

- Frequent cleaning of the ceramic glass is recommended. We recommend using a good quality ammonia free gas fireplace glass cleaner that is available at any hearth retail location. Take care to avoid scratching glass while cleaning. **DO NOT CLEAN WHILE HOT.** Never use common household cleaners to clean the glass.
- Keep the appliance area free from combustible materials, such as paper, wood, clothing, gasoline and flammable solids, liquids and vapors
- Visually check the height and color of the burner and pilot flames
- Touch up the paint if necessary using a high temperature metallic black paint. Allow the paint to dry prior to lighting the fireplace.

Once a year, have a qualified service technician:

- Perform the regular services listed above
- Inspect and operate the pressure relief mechanism (door buckles) to verify they are free from obstruction and operate properly
- Carefully remove the logs and gently brush off any loose carbon deposits. This job is best done outside the house, wearing a dust mask. The logs are very fragile, take care not to break them. Do not wash logs with any liquid. While the logs are removed, check that all burner openings are not obstructed and it is recommended you use a vacuum cleaner to clean off any dust or lint
- Vacuum and clean any lint accumulations or debris in the firebox, on the burners, on the pilot, at the primary air opening, on the convection air blower and in any combustion and convection air passageways
- After cleaning, the logs and embers must be replaced according to the instructions in this manual
- Inspect the operation of the flame safety system pilot and gas valve
- Inspect and ensure the lighting of the main burner occurs within 4 seconds of the main gas valve opening. Flames should match those shown in **Page 47**
- Completely inspect the appliance and the venting system, if the vent pipe or seal is found to be defective, replace and or reseal (follow the instructions found in the venting instructions in this manual)
- Inspect the condition of the vent and vent terminal for sooting or obstruction and correct if present
- Test and measure the flame failure response time of the flame safety system. It must de-energize the safety shutoff in no more than 30 seconds
- Check all accessible gas-carrying tubes, connections, pipes and other components for leaks

WARNING:

All parts removed or disturbed, including guards and grills, must be properly replaced after maintenance. Service and repair must be conducted by a qualified service person. If these instructions are not followed, a fire or explosion may result, causing property damage, personal injury or loss of life.

SERVICING UNDER WARRANTY

Before servicing, read the terms and conditions of the Archgard warranty at the back of the manual. Contact the Authorized Archgard dealer where you purchased the appliance from and provide them with details of the problem together with the initial installation information (from the back of this manual).

WARNING: Servicing of this appliance **must be conducted by a qualified Archgard service technician**. Improper servicing, adjustment or alteration of this appliance may cause property damage, personal injury or loss of life. All servicing should be conducted with the appliance cold. All replacement parts must be authorized by Archgard for suitability.

ADJUSTING PRIMARY AIR

Caution: Wear gloves when adjusting the primary air with the appliance hot.
 Note: the Shutter is set at the factory and normally only requires resetting at higher altitudes.

1. Open the lower louver.
2. Unscrew the 4 screws holding the control panel and remove the panel. (Fig. 1)
3. The primary air adjustment wing nut is located behind and to the left of the control valve.
4. Loosen the wing nut and slide the primary air shutter to the right to increase primary air and to left to reduce primary air.
5. Tighten the wing nut after adjustment.

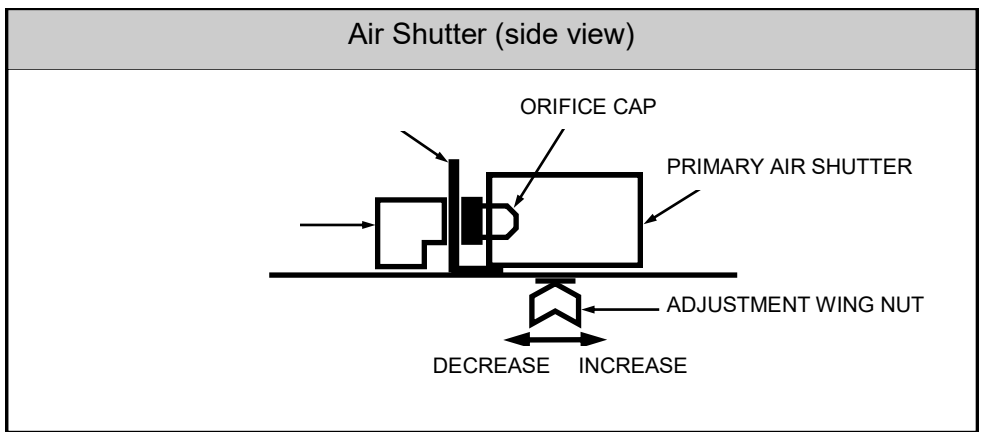
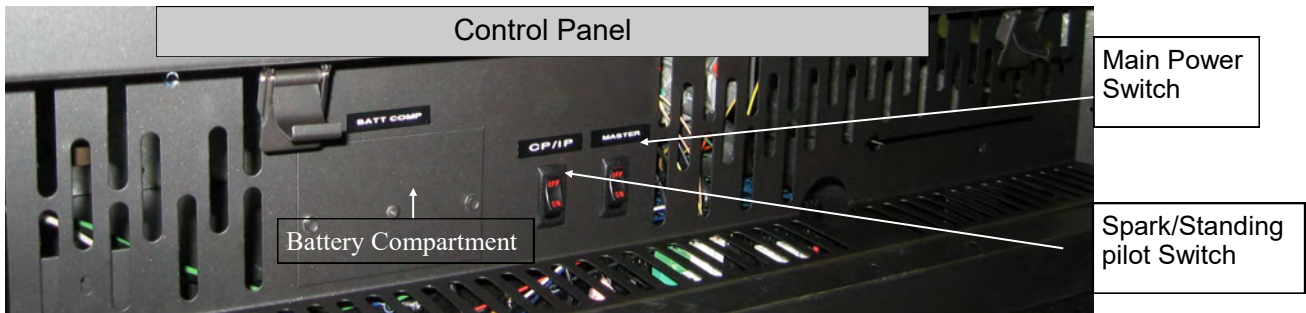

ADJUSTING PRIMARY AIR

NOTE: (Fig.1) is to give an example of a correct and incorrect flame pattern. It is not a true representation of what the 72-DVTE30-2 will look like in your home environment.

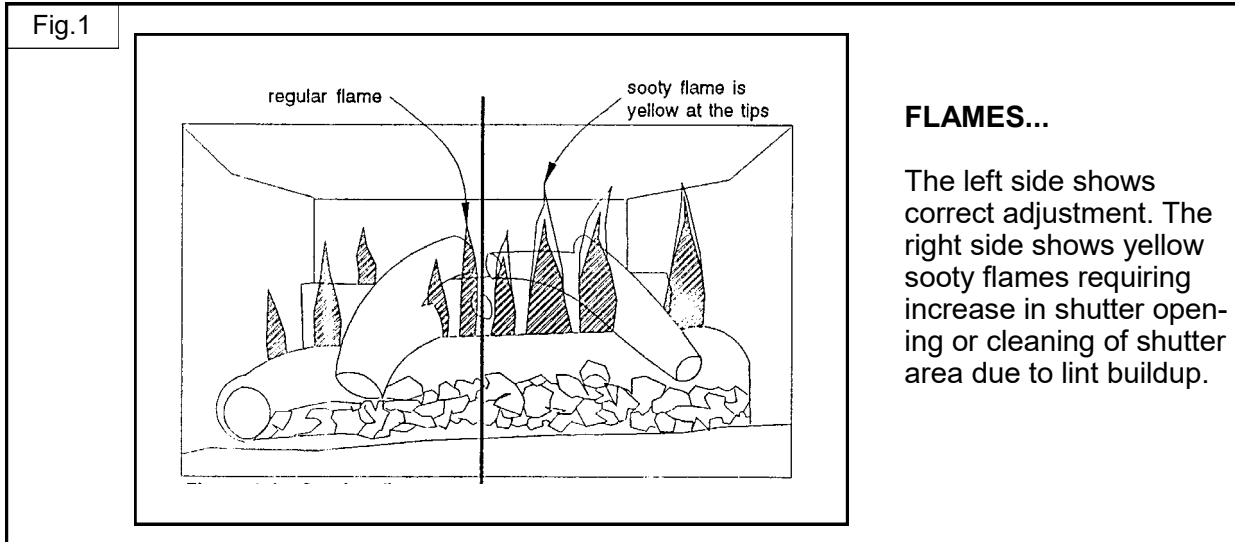

CHANGING MAIN BURNER ORIFICE

1. Remove the glass door. Follow GLASS DOOR REMOVAL instructions within this manual.
2. Remove the wing nut and washer from the Primary Air Sleeve
3. Locate & slide the Primary Air Sleeve fully toward the left. This will allow the sleeve to disconnect from the burner tube. Follow ADJUSTING PRIMARY AIR instructions within this manual for reassembly.
4. Remove the grate and front logs from the pan burner. See LOG PLACEMENT for instructions.
5. Unscrew the two mounting screws that are located at the back rear of the pan burner.
6. Carefully remove the burner with Air Sleeve by lifting it out.
7. Use a 1/2" (13 mm) wrench to remove the orifice cap.
8. Change the orifice cap to the fuel type desired. Use a small quantity of gas thread seal compound. Do not over tighten.
9. Reverse steps 6 to 1.

THIS APPLIANCE IS EQUIPPED FOR NATURAL GAS. An additional CONVERSION kit is required to convert for Propane use. To order the CONVERSION kit, please contact your Authorized Archgard Dealer.

CHECKING INLET AND OUTLET GAS PRESSURE

1. Open the lower grills (louvers).
2. The pressure test taps are located on the valve. The taps are located in the gas valve front face. The inlet is marked 'IN' and the outlet is marked 'OUT'. See Fig.1.
3. Loosen the set screw inside the tap with a 1/8" (3 mm) wide flat screw driver.
4. Connect a 1/4" (6 mm) rubber tube to the tap post and a manometer.
5. Verify the readings obtained are within specs (as shown on the appliance rating plate)
6. Be sure to tighten the set screw inside the tap after you are finish taking pressure readings.
7. Check for leaks.

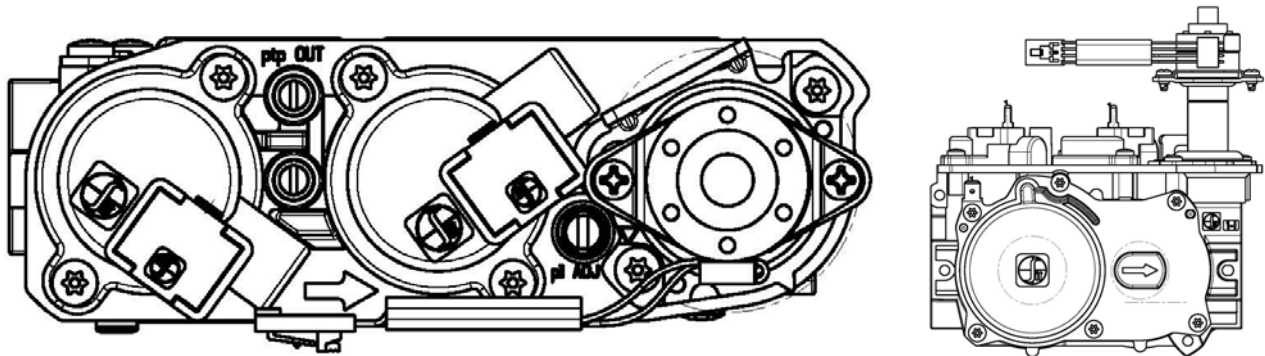

CHECKING AND ADJUSTING PILOT

The pilot flame should have the characteristic as shown in the illustration to the right. The flame should not have yellow tips but should engulf the thermocouple and thermopile. It can be adjusted by turning the screw marked "pilot" on the control valve.

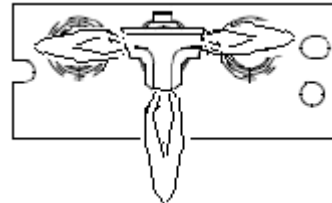

CONVERTIBLE PILOT ORIFICE

The pilot assembly is convertible to the type of gas being used, simply unscrew the body by using a 7/16" (11 mm) wrench turn a 1/4 open then push the small metal tab across to the other side of the body and retighten. **Call your local Authorized Archgard Dealer to purchase the correct fuel conversion kit for your gas appliance.**

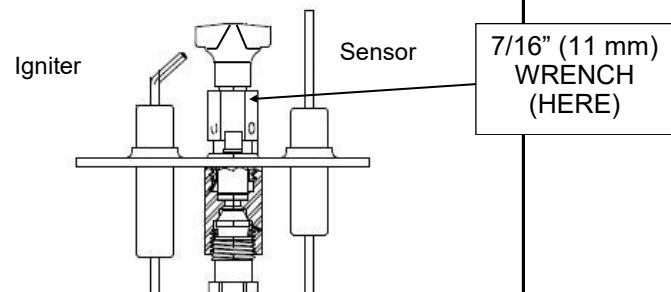

REPLACING CONVECTION BLOWER

Caution: Label all wires prior to disconnection when servicing controls. Wiring errors can cause improper and dangerous operation. Verify proper operation after servicing. This appliance, when installed, must be electrically grounded in accordance with local codes or, in the absence of local codes, with the **National Electrical Code, ANSI/NFPA 70**, or the **Canadian Electrical code, CSA C22.1**.

NOTES:

- Ensure that the main power and breaker system is turned OFF before removing the fan.
- Make sure the fireplace has been turned off and is cool to the touch.
- Mark all wires to be removed for proper reassembly.

CAUTION: Wiring errors cause improper and dangerous operation.

The convection blower is located at the bottom of the appliance at the back.

1. Remove front grate from behind the louvers
2. Loosen the 3 screws holding the blower.
3. Unplug fan connection to module. Remove green plug from old blower wiring to reuse on new blower.
4. Reverse above steps to install new fan.

VALVE TRAY ASSEMBLY

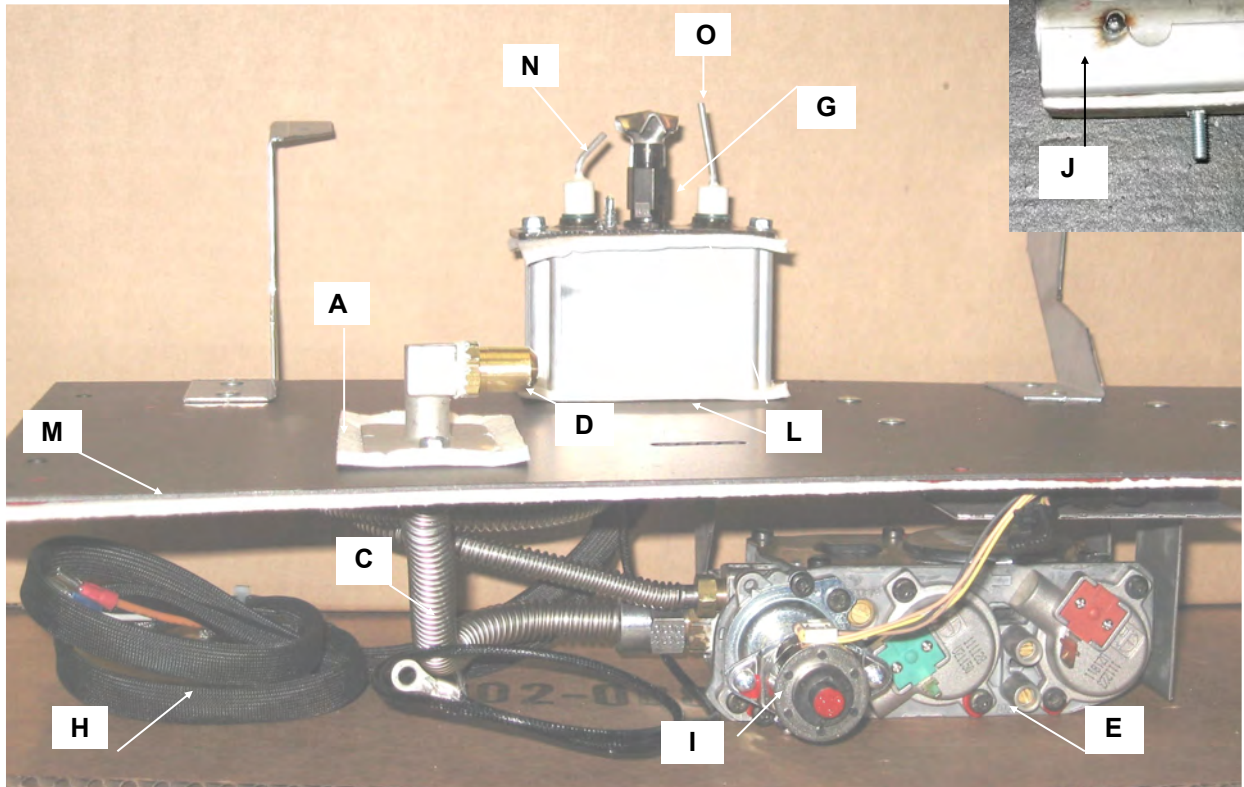

	Item #	Item Description	Qty	Unit
A	314-0015	Flex tube gasket	1	EA
B	300-0120	Wing Nut, Plated Steel (Air Shutter)	1	EA
C	301-6007	7" Flex line assembly ,flanged orifice	1	EA
D	301-0068-37	Orifice (Main Burner Orifice) Drill to # 37 DMS (2.65 mm) for Natural Gas	1	EA
	301-0068-52	Orifice (Main Burner Orifice) Drill to #52 DMS (1.62 mm) for Propane	1	EA
E	308-6017	Sit 885 Electronic Gas Valve	1	EA
G	308-0124	Pilot Assembly	1	EA
H	n/a	Spark and Sensor Leads (from pilot assembly)		
I	308-6018	LP Stepper Motor (Regulator)	1	EA
J	800-0060	Air Shutter Assembly	1	EA
K	314-0131	Air Shutter Gasket	1	EA
L	314-0139	Pilot Assembly Box Gasket	2	EA
M	314-0124	Valve Tray Gasket	1	EA
N	308-0125	PSE Spark Igniter	1	EA
O	308-0126	PSE Flame Sensor	1	EA

PARTS LIST - Logs and Pan Burner

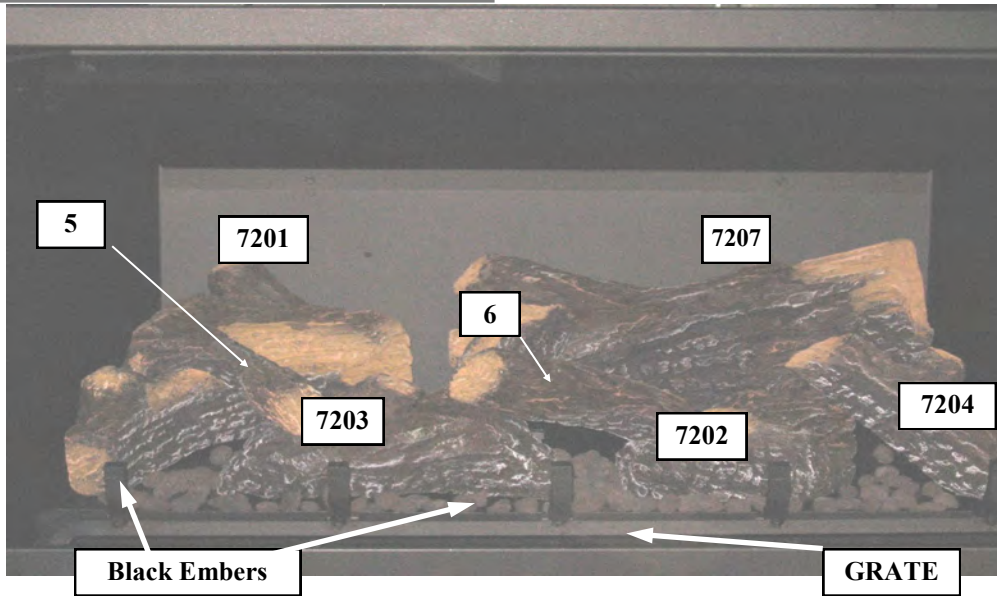

Pan Burner



Item #	Item Description	Qty	Unit
310-634720-1	Log 7201	1	EA
310-634720-2	Log 7202	1	EA
310-634720-3	Log 7203	1	EA
310-634720-4	Log 7204	1	EA
310-634720-5	Log 7205 (there is only 5 on log)	1	EA
310-634720-6	Log 7206 (there is only 6 on log)	1	EA
310-634720-7	Log 7207	1	EA
872-0060-R2	Grate	1	EA
872-0053	Pan Burner	1	EA
310-0020	Black Embers (2 cup bag)	1	EA
310-0019	Platinum Embers	1	BAG

REPLACEMENT PARTS LIST ARCHGARD 72-DVTE30-2
--

Item #	Item Description	Qty	Unit
200-1917-16	Owner's Manual - English	1	EA
200-1917F-07	Owner's Manual - French	1	EA
300-0031	Magnet Pull (holds bottom louver)	2	EA
300-0034	Catch, Door Latch. (Buckle for door)	2	EA
700-0140	Vent Restrictor #1	1	EA
700-0141	Vent Restrictor #2	1	EA
700-0142-REVA	Vent Restrictor #3	1	EA
72-BS	Barrier Screen	1	EA
Fan Components			
RF-305-0024	Fan with motor and blades. 120VAC, 24watt (QLN65-0018)	1	EA
702-0050	Fan Heat Shield	1	EA
Flat Glass Door			
813-0075	Complete Replacement Door. Includes, glass, gasket and door frame (Black Square Door Assembly)	1	EA
813-0076	Complete Replacement Door. Includes, glass, gasket and door frame (Black Arch Door Assembly)	1	EA
Electronic Components			
308-6012	Wire Harness	1	EA
308-6060	SIT Proflame II Dynamic Start Advantage with Continuous Pilot on Demand	1	EA
308-6024	Wall Mount Remote	1	EA
305-0149	ON/OFF Rocker Switch	2	EA
305-0060	Battery Holder	1	EA
RP-305-2080	Fuse, 3.15A, 215V (pack of 5)	1	EA

REPLACEMENT PARTS LIST ARCHGARD 72-DVTE30-2 (continued)
Optional Brick Panel Kits

Item #	Replacement parts for BBAY-70 Bay Door	Qty	Unit
300-0031	Magnet Pull	2	EA
307-0030	Glass, 6mm Tempered (Middle Piece)	1	EA
307-0031	Glass, 6mm Temp (Side Piece)	2	EA
314-0006	Flat Gasket	72	IN
	Replacement parts for Eclipse Front		
72-FSEB	Eclipse Front	1	EA
	Brick Panel Kit (Quebec City Red)		
72-BRPL-QCR-2	Ceramic Brick Panel Set	1	ST
702-0044	Brick Panel Clips	2	EA
	Brick Panel Kit (Quebec City Grey)		
72-BRPL-QCG-2	Complete Brick Panel Set	1	EA
	Brick Panel Kit (Reflective Glass)		
72-BRPL-RG	Complete Reflective Glass Panel Set	1	EA
702-0045	Glass Panel Clips	2	EA

This Limited Warranty is made by ARCHGARD INDUSTRIES LTD., hereinafter referred to as "Archgard". Archgard warrants to the original purchaser of an Archgard gas burning fireplace(s) that the product will be free from defects in materials and workmanship under normal use and service, for a "lifetime". All warranty repairs are to be performed by an authorized Archgard Dealer during the warranty period. Other repair / service company charges for any work done during the warranty period, will be the responsibility of the home owner.

INCLUSIONS: "LIFETIME LIMITED WARRANTY"

All heat exchangers and combustion chamber
Ceramic Fiber Logs and Ceramic Brick Panels, against splitting and cracking due to heat exposure

NOTE: Discoloration and some minor movement including warping of certain parts are normal and are not a defect; therefore, not covered under warranty.

INCLUSIONS: "SEVEN YEAR LIMITED WARRANTY"

Burner tubes and pans

INCLUSIONS: "TWO YEAR LIMITED WARRANTY"

Ceramic Glass against thermal breakage
Trims and accessories from splitting or separating
Electronic Control Module, Remote Transmitter

Items included with ten-year and two-year limited warranty will be covered under "Parts & Subsidized Labour" to the original purchaser for one (1) year and "Parts Only" thereafter from original date of purchase.

INCLUSIONS: "ONE YEAR LIMITED WARRANTY"

Blowers, fans and fan motors, wiring, rheostats and thermodiscs
Rocker switches, spill switches and wiring to them
Gas control valves, pilot assemblies including thermopiles, thermocouples, electrodes and igniters
Paint peeling or cracking

Items included in the one-year limited warranty will be covered under "Parts & Subsidized Labour" to the original purchaser for one (1) year from date of purchase.

WHAT TO DO IN THE EVENT OF A PROBLEM:

Thoroughly read your "Owner's Installation, Operation & Maintenance Manual"

If you cannot solve the problem, contact your Archgard dealer or representative

When calling for assistance, please have the following information:

Model of your fireplace Serial Number

Place of Purchase

Date of Purchase

Problem Description

NOTE: Warranty will be void if work is carried out by an unqualified person(s). Only original Archgard parts may be used. Please consult your Archgard dealer or representative if in doubt about a replacement part(s).

All warranty repairs are to be performed by an authorized Archgard Dealer during the warranty period. Other repair / service company charges for any work done during the warranty period, will be the responsibility of the home owner.

OBTAINING WARRANTY SERVICE:

The original purchaser shall return the defective part(s) to the original authorized Archgard dealer – transaction prepaid, along with the serial number of the appliance and original proof of purchase. Any defective part, in our judgment, will be repaired or replaced at Archgard's discretion. The dealer must obtain approval from Archgard before any repairs are made.

WARRANTY LIMITATION:

THIS LIMITED WARRANTY IS MADE IN LIEU OF ALL OTHER WARRANTIES, EXPRESSED OR IMPLIED AS TO QUALITY, MERCHANTABILITY OR FITNESS FOR PARTICULAR PURPOSE.

The appliance is only warranted for the use as intended by the installation and operating instructions and local building codes. The warranty will not cover damage due to accident, misuse, abuse, alteration, improper installation or "Acts of God". This limited warranty is void unless the appliance is installed by a qualified Archgard installer, in accordance with the instructions furnished with the appliance. Some Provinces or States do not allow limitations on how long an implied warranty lasts, so the above limitations may not apply to the original purchaser. Any damage resulting from defects in this product is limited to the replacement of the defective part(s) and does not include incidental and consequential exposures sustained in connection with the product. This includes facing(s), mantle(s), cabinet(s), tile(s) or any other finishes resulting from removal of any gas appliance. This warranty is limited to residential use only and gives the consumer specific rights. These rights may vary from State to State or Province to Province.

WARRANTY CONDITIONS & REQUIREMENTS:

1. You are the original purchaser – this warranty is not transferable.
2. Installation of the fireplace must be performed by a qualified Archgard installer.
3. Installation and operation must comply with the installation and operation instructions.
4. All optional accessories are covered for one (1) year from the date of purchase.
5. This warranty does not offer coverage for light bulbs or batteries (whether factory, dealer, or installer supplied). This includes any damage stemming from non-use.
6. Damage during shipping or handling of components, defects resulting from improper installation or service, or misuse of the fireplace or fireplace components are not covered under this warranty.
7. This warranty does not cover any part of the fireplace or any component which has been exposed to or submerged under water.
8. Archgard must be notified by the dealer the fireplace was purchased from or a qualified Archgard technician of the defect.
9. Annual service of the fireplace as required in the installation manual must be performed by a qualified Archgard technician (service records may be required to claim a warranty).
10. All previous warranty service must have been performed by a qualified Archgard technician (service records may be required to claim a warranty).
11. Travel time or mileage to the original purchaser's residences is not covered under this warranty. We suggest that you pre-arrange travel expenses with your Authorized Archgard Dealer.
12. Freight on warranty shall be covered for the first two years of the warranty period.

Frequently Asked Questions

Listed below are some frequently asked questions about your Archgard Gas Fireplace. If you have questions that are not listed below, or are not answered in this manual, please contact your Authorized Archgard Dealer.

Q. My glass has a condensation “fog” when the appliance is first lit.

A. Condensation is normal and will disappear in a few minutes after the glass is heated.

Q. I have a white “film” on my glass. What is the best way to clean the inside of the glass?

A. Frequent cleaning of your glass is recommended. Archgard recommends using a good quality “gas fireplace” glass cleaner that is available at all authorized dealers. Do not use abrasive materials, and do not clean the glass or the appliance when the unit is hot.

Q. How do I care for my gold plated trims?

A. Archgard recommends a cleaning with a damp cloth. DO NOT use chemical cleaners as they may harm the finish, and void your warranty. NOTE: If the top louvers, or top overlay starts to discolor, check the door gasket seal and replace if necessary.

Q. My fan/blower makes a “whirring” or “humming” noise.

A. Your Archgard gas appliance uses a powerful fan to push heated air into your room. It is not unusual to hear a “humming” noise when your fan is running. Note: the sound will change depending on the setting that your fan speed control is set at.

Q. I hear a “click” when my fan system activates.

A. When your appliance reaches temperature, it will activate the THERMODISC “fan switch”. The switch closes the electrical circuit that allows the fan to turn on. This is a normal sound.

Q. I hear a “ticking”, “cracking” or “pinging” sound when my fireplace is running, and after it is turned off.

A. The different gauges of steel used to manufacture your fireplace will expand and contract at different rates when your fireplace is on, and will continue as your fireplace completes its heating function. You will likely hear these same sounds more on start up and shut down. This is normal for steel fireplaces.

Q. When my appliance is OFF and my pilot light is lit, I hear a “whisper” sound.

A. The lit pilot can make a small noise. Sometimes in extreme wind conditions you may be able to hear air entering into the firebox chamber.

Q. I hear a “click” when my main burner turns ON or OFF.

A. Your Gas Control Valve will make a clicking sound when it opens to allow gas to flow to the main burner. This is a normal part of the operating system.

Q. Can I burn wood and other materials in my gas fireplace.

A. No! Burning anything other than natural or LP gas in a gas fireplace or stove will create a potential fire hazard and present a danger to your home and its occupants. Only burn the gas fuel for which the unit was originally designed.

Q. Can I shut my pilot off in the summer?

A. You will save energy by turning off the pilot light if you are not using your appliance for the hot summer months. When in continuous pilot ignition on demand (CPI) mode the pilot will remain lit for seven days after the fireplace is used. When seven days have passed the system will turn the pilot off. When in IPI mode, the pilot will only remain on when the main burner is on.

Q. Why does my fireplace start with a low flame? Shouldn't the flame size match the remote setting?

A. Dynamic Start Advantage was designed to create a draft by starting the fireplace on low and automatically increasing the flame to match the remote setting after two minutes. This system helps to create a better flame appearance, reduce condensation on the glass, and provide years of carefree operation.

Q. Can I position my gas logs in a different fashion or use a different log set?

A. No. Your gas fireplace is an engineered system that includes the firebox, burner, logs, venting and options which are tested and listed by CSA. Changing any specifications or placement of the logs could void your manufacturer's warranty, and possible even your homeowner's warranty.

NOTES

NOTES

NOTES

POSTAGE

WARRANTY REGISTRATION

**ARCHGARD INDUSTRIES LTD.
PO BOX 318
RAYMOND, AB
TOK 2S0**

FOLD DOWN AT LINE

FOLD DOWN AT LINE & TAPE CLOSED

Model # : _____ Serial #: _____ Date Installed: _____ / _____ / _____

Name: _____ Address: _____ mm dd yyyy

City: _____ State/Prov: _____ ZIP: _____ Phone: (_____) _____

Dealer's Name & Address: _____

City: _____ State/Prov: _____ ZIP: _____ Phone: (_____) _____

Installer's Name & Address: _____

City: _____ State/Prov: _____ ZIP: _____ Phone: (_____) _____

Why did you choose this product? _____

*Thank you for purchasing our product and filling out this warranty card. Save time by completing this form at
www.archgard.com/warranty-registration*

CUT ALONG LINE

CUT ALONG LINE

CUT ALONG LINE

ARCHGARD INDUSTRIES LTD.

300 Railway Avenue
Raymond, AB T0K 2S0
Canada

www.archgard.com