



## INSTALLATION, OPERATION, AND MAINTENANCE MANUAL

### Optima 72

Model: 72-DVT30N-2

Direct Vent Fireplace Heater  
Serial Numbers 046047 and higher

**WARNING:**

**FIRE OR EXPLOSION HAZARD**

Failure to follow safety warnings exactly could result in serious injury, death, or property damage.

- Do not store or use gasoline or other flammable vapors or liquids in the vicinity of this or any other appliance.

**- WHAT TO DO IF YOU SMELL GAS:**

- Do not try to light any appliance
- Do not touch any electrical switch; do not use any phone in your building
- Leave the building immediately
- Immediately call your gas supplier from a neighbor's phone. Follow the gas suppliers instructions
- If you can not reach your gas supplier, call the fire department

- Installation and service must be performed by a qualified installer, service agency or the gas supplier.

Installation Manuals available through your local dealer by visiting our website at: [www.archgard.com](http://www.archgard.com)

**For use with natural gas or propane**  
(Conversion kit required for Propane use)

**INSTALLER:**

LEAVE THIS MANUAL WITH THE APPLIANCE.

**CONSUMER:**

RETAIN THIS MANUAL FOR FUTURE REFERENCE.

This appliance may be installed in an aftermarket permanently located, manufactured home (USA only) or mobile home where not prohibited by local codes.

This appliance is only for use with the type of gas indicated on the rating plate. This appliance is not convertible for use with other gases, unless a certified kit is used.



## DANGER



**HOT GLASS WILL  
CAUSE BURNS.**

**DO NOT TOUCH GLASS  
UNTIL COOLED.**

**NEVER ALLOW CHILDREN  
TO TOUCH GLASS.**

A barrier designed to reduce the risk of burns from the hot viewing glass is provided with this appliance and must be installed for the protection of children and other at-risk individuals.



We recommend that our gas hearth products be installed and serviced by professionals who are certified in the U.S. by the National Fireplace Institute® (NFI) as NFI Gas Specialists.

**Archgard Fireplace Products**

300 Railway Avenue  
Raymond, AB T0K 2S0  
Canada

**Gas Fireplace  
Efficiency Rating**

**SIT 820:  
65.94%**

Based on CSA P.4.1-15

**Gas Fireplace  
Efficiency Rating**

**SIT 821:  
67.80%**

Based on CSA P.4.1-15



200-1907-11  
April 06, 2026

# TABLE OF CONTENTS

Introduction	3
Rating Plate Sample	4
Installation Checklist	5
Caution and Safety Instructions	6
Appliance Certification, Installation Codes and Specifications, High Altitude Installation	7
Gas Connections	8
Appliance Dimensions and Clearance to Combustibles	9
Clearances	10
Framing Dimensions, Termination	12
Locating Gas Fireplace and Vent Termination Locations	13
Allowable Termination Locations	14
Approved Vent Components and Venting Connection	15
Venting	16-25
Electrical Connections (Fan System) and Fan Wiring Diagram	26
Log Placement	27-31
Optional Brick Installation	32-34
Optional Wall Switch, Thermostat or Remote Control. Suggested wiring.	35
First Fire and Lighting Instructions (CAUTION)	36
Final Installation Check and Initial Operation	37
Lighting Instructions on Rating Plate	38
Glass Door Removal and If your Glass Breaks	39
Safety Barrier Installation	40
Louver (grill) instructions	41
Troubleshooting Guide	45-46
Maintenance and Cleaning the Appliance	47
Servicing Under Warranty & Adjusting Primary Air Shutter	48
Adjusting Primary Air Shutter (Continued) Changing Main Burner Orifice	49
Checking Inlet/Outlet gas pressures, Adjusting Pilot and Convertible Pilot Orifice	50
Pilot Polarity (SIT 821), Replacing Convection Blower (Fan)	51
Valve Tray Assembly and parts list	52
Log and Pan Burner parts list	53
Replacement Parts List	54-55
Warranty	56
Frequently Asked Questions	57
Warranty Registration	59

# INTRODUCTION

Congratulations on choosing an Archgard fireplace!

The 72-DVT30N-2 is one of the most advanced direct vent fireplace heaters available. It is solidly designed using the latest technology and manufactured to the highest quality. It is our aim to provide you with an appliance for many trouble-free years of reliable service.

The following are just some of the many features within your new gas fireplace:

- Heater Classification                      The 72-DVT30N-2 is classified as a heating appliance. In conjunction with an optional thermostat, the 72-DVT30N-2 can be operated continuously for zone heating.
- High Efficiency                              The 72-DVT30N-2 has one of the highest efficiencies of any gas fireplace, which means that it is less expensive to operate.
- Adjustable Fan Speed                      Heat circulation fan can be fully adjusted from high, medium or low speeds to suit your comfort level.
- Adjustable Flame                            The flame aesthetics and heat output can be adjusted to suit your heating needs.
- Solid Construction                         The 72-DVT30N-2 is constructed mainly of 14 and 18 gauge galvanized and aluminized steel for long life and durability.
- Millivolt Control System                 The gas control system is “thermostat-ready” for any optional millivolt wall thermostat or wireless remote control. This fireplace uses a gas control valve can be purchased with either a Continuous Pilot Ignition (USA only) or Continuous Pilot on Demand Ignition system (also known as a Pilot on Demand (POD) with 7 day timer).
- Convertible                                 The 72-DVT30N-2 is easily convertible between top and rear vent configurations.

**Please read this manual carefully prior to installation and operation of the appliance. Proper installation, operation and maintenance of the appliance will provide you with many years of enjoyment.**

## Model Number Definition (72-DVT30N-2)

72	Number assigned to identify the fireplace
DV	Direct Vent
T	Top Vented
30	Natural Gas Input Rating in BTU
N	Natural Gas / Traditional Log Burner
-2	Revision Number

**SIT 820:** This millivolt control system includes a continuous pilot (also known as a standing pilot). Once lit, the pilot will continue to burn until turned off. This option is not available in Canada.

**SIT 821:** This millivolt control system includes Continuous Pilot on Demand. Once lit, the pilot will continue to burn until 7 days without use. If the fireplace is not used for 7 days, the pilot will extinguish. This feature is intended to save fuel. Simply relight the fireplace to start the 7 day timer again.

### We recommend you record the following information:

Fireplace Model Number: 72-DVT30N-2 Serial Number: \_\_\_\_\_

Date of Installation: \_\_\_\_\_

Type of Gas Used by the Fireplace:  Natural Gas  Propane

Dealer's Name & Address: \_\_\_\_\_

\_\_\_\_\_

Dealer's Phone Number: \_\_\_\_\_

\_\_\_\_\_

Please complete and submit the warranty registration card included in the back of this manual or by visiting us at: [www.archgard.com/warranty-registration](http://www.archgard.com/warranty-registration)

**RATING PLATE SAMPLE**



DO NOT REMOVE THIS LABEL

**MODEL: 72-DVT30N-2**  
Manufactured as Natural Gas

SIT 820	SIT 821
---------	---------

VENTED GAS FIREPLACE HEATER and GAS-FIRED APPLIANCES FOR USE AT HIGH ALTITUDES.  
Tested to: ANSI Z21.88 / CSA 2.33-2019, CSA 2.17-2017, CSA – P.4.1-15, CSA C22.2 No.3 - M1998(R.2014).  
This vented gas fireplace heater is not for use with air filters. Certified for use in both CANADA and USA.

VENTED GAS FIREPLACE HEATER-NOT FOR USE WITH SOLID FUEL.

	NG	LPG
Input rating	20,100 - 30,000 BTU/hr (5.9 - 8.8 kW)	23,000 - 30,000 BTU/hr (6.7 - 8.8 kW)
Manifold Pressure	1.6 - 3.5 in. W.C. (0.4 - 0.9 kPa)	6.4 - 10.0 in. W.C. (1.6 - 2.5 kPa)
Orifice size	#37 DMS (2.65 mm dia.)	#32 DMS (1.62 mm dia.)
Minimum supply pressure for purpose of input adjustment.	5 - 14.0 in. W.C. (1.2 - 3.5 kPa)	11.0 - 14.0 in. W.C. (2.74 - 3.5 kPa)
Burner Primary Air Setting	1/4" (3mm) Closed	1/2" (13mm) Open
Altitude	0 - 4500 ft (0 - 1372 m)	0 - 4500 ft (0 - 1372 m)
Fireplace Efficiency (FE) Rating	SIT 820: 65.94% SIT 821: 67.80 %	
Electrical rating	120 VAC, 60 Hz, less than 2 A.	
Replacement fan	Part no. RF-305-0024 fan or blower assembly must be used	
Keep burner and control clean. See Instructions accompanying the heater. Optional fuel conversion kit : See manual	Minimum clearances to Combustibles: Sides, back & top from standoffs: 0" (0 mm). Sides from Faceplate: 1" (25 mm) Max 6" (150 mm) mantle at min 45" (1143 mm) from bottom of appliance. Venting: Sides & Bottom: 1" (25 mm), Top: 2" (50 mm). Ceiling: 84" from bottom of appliance.  See Manual for additional dimensions and clearances	

This appliance must be installed in accordance with local codes, if any; if none, follow the National Fuel Gas Code, ANSI Z223.1/NFPA 54, or Natural Gas and Propane Installation Codes, CSA B149.1. Electrical connections and grounding must be in accordance with local codes, if any; if none, follow the current CAN/CSA C22.1 in Canada and ANSI/NFPA 70 in the US. This appliance is certified for installation in a bedroom or a bed sitting room. This appliance is only for use with the gas indicated on the rating plate and may be installed in an aftermarket, permanently located, manufactured (mobile) home where not prohibited by local codes. See owner's manual for details. This appliance is not convertible with other gases, unless a certified kit is used.

**WARNING:** Improper installation, adjustment, alteration, service, or maintenance can cause injury or property damage. Refer to the owner's information manual provided with this appliance. For assistance or additional information consult a qualified installer, service agency, or the gas supplier. This appliance must be properly connected to a Direct Vent venting system in accordance with the manufacturer's installation instructions.

**WARNING:** Failure to install this appliance per the manufacturer's instructions or failure to use only parts specifically approved with this appliance may result in property damage or personal injury.

**WARNING:** Do not operate the appliance until all sections have been assembled and installed in accordance with the manufacturer's instructions.

**WARNING:** Operation of this appliance when not connected to a properly installed and maintained venting system can result in carbon monoxide (CO) poisoning and possible death.

ONLY DOORS CERTIFIED WITH THE APPLIANCE SHALL BE USED.  
For use only with barrier part # 72-BS. Follow installation instructions.

Made in Canada by:  
Archgard Industries Ltd.  
7116 Beatty Dr., Mission, B.C.

December 2020 303-0136-05



MANUFACTURE DATE:

## Installation Checklist

This standard installation checklist is to be used by the installer in conjunction with, not instead of, the instructions contained within this installation manual.

<b>Customer:</b> _____	<b>Date Installed:</b> _____	
<b>Install Address:</b> _____	<b>Location of Fireplace:</b> _____	
	<b>Installer:</b> _____	
<b>Appliance Install:</b>	<b>YES</b>	<b>IF NO, WHY NOT?</b>
Standoffs and side nailing flanges are installed.		
Fireplace is leveled and secured.		
<b>Venting:</b>	<b>YES</b>	<b>IF NO, WHY NOT?</b>
Venting configuration complies with vent diagrams.		
Venting installed and secured in place maintaining proper clearances.		
<b>Maintained 1/4" rise for every 1 ft. on horizontal run.</b>		
Terminations installed and sealed in compliance with local building code.		
Direct vent termination is highest point in vent assembly.		
<b>Wiring / Electrical:</b>	<b>YES</b>	<b>IF NO, WHY NOT?</b>
Connected to household 110/120v per local codes.		
Unit is properly grounded.		
<b>Gas:</b>	<b>YES</b>	<b>IF NO, WHY NOT?</b>
Proper appliance for fuel type?		
Was a conversion performed?		
Leak check performed & inlet and manifold pressures verified?		
Verified proper air shutter setting?		
<b>Finishing</b>	<b>YES</b>	<b>IF NO, WHY NOT?</b>
Only noncombustible material installed in noncombustible areas.		
Clearances meet installation manual requirements.		
Mantels and/or projections comply with install manual.		
<b>Appliance Setup:</b>	<b>YES</b>	<b>IF NO, WHY NOT?</b>
Burner media / log set, glass door, and screen installed according to manual		
Manual given to home owner.		
Did you check flame modulation?		
<b>Comments:</b> _____		

## Safety Information

### Caution

**FOR YOUR SAFETY** - Do not install or operate your **72-DVT30N-2** without reading and understanding this manual. Any installation or operational deviation from this instruction manual voids the warranty and may prove hazardous.

- This appliance must be installed by a qualified gas installer and the installation must conform to the installation codes
- Provide adequate clearance around air openings into combustion chamber
- Never obstruct front openings
- Provide adequate clearances for proper operation and servicing of the appliance
- This appliance must be properly connected to an approved venting system and must not be connected to a chimney flue serving a separate solid fuel burning appliance
- Flow of combustion and ventilation air must not be obstructed - always provide adequate combustion and ventilation air
- Always provide adequate clearance around the intake and exhaust openings

### Safety

- Due to high temperatures, the appliance should be located out of traffic and away from furniture and draperies
- Children and adults should be alerted to the hazards of high surface temperature and stay away to avoid burns or clothing ignition
- If this appliance is installed directly on carpeting, tile, or other combustible material other than wood flooring, the appliance shall be installed on a metal or wood panel extending the full width and depth of the appliance
- Young children should be carefully supervised when they are in the same room as the appliance. Toddlers, young children and others may be susceptible to accidental contact burns. A physical barrier is recommended if there are at risk individuals in the house. To restrict access to a fireplace or stove, install an adjustable safety gate to keep toddlers, young children and other at risk individuals out of the room and away from hot surfaces
- Do not store or place combustibles, gasoline, and other flammable vapors and liquids near the appliance
- Clothing or other flammable material should not be placed on or near the appliance
- **WARNING:** Do not operate appliance with the glass front removed, cracked, or broken. Removal of the glass should be done by a licensed or qualified service person. Do not to strike or slam the glass
- Any safety screen or guard removed for servicing an appliance must be replaced prior to operating
- Installation and Repair should be done by a qualified service person. The appliance should be inspected before use and at least annually by a professional service person. More frequent cleaning may be required due to excessive lint from carpeting, bedding materials, etc. It is imperative that the control compartments, burners and circulating air passageways of the appliance are kept clean
- Under no circumstances should any solid fuel (wood, coal, paper or cardboard, etc.) be used in this appliance
- Keep burner and control compartment clean
- Do not use this appliance if any part has been under water. Immediately call a qualified service technician to inspect the appliance and to replace any part of the control system and any gas control which has been under water
- **California Proposition 65 Warning:** This product can expose you to chemicals including Carbon Monoxide, that is an externally vented by-product of fuel combustion, which is [are] known to the State of California to cause cancer, birth defects, or other reproductive harm. For more information, visit [www.P65Warnings.ca.gov](http://www.P65Warnings.ca.gov).

Each Archgard Gas Fireplace is checked and tested at the factory prior to being packaged and shipped to our dealers and finally installed in your home. Before leaving this unit with the customer, the installer must ensure that the appliance is firing correctly and that the electrical system is in working order. The Installation Checklist should be used to ensure the proper installation of this gas fireplace heater and to document any deviations from a typical install.

Any alteration to the product that causes carbon or soot deposits that results in any damage or requires cleaning is not the responsibility of the manufacturer.

## APPLIANCE CERTIFICATION

This appliance is tested and safety approved under the following US and Canadian gas appliance standards:

- ANSI Z21.88-2019 / CSA 2.33-2019 Vented Gas Fireplace Heaters,
- CAN/CGA-2.17-M91 Gas-Fired Appliances For Use at High Altitudes,
- CSA – P.4.1-15 – Testing Method for Measuring Annual Fireplace Efficiency,
- CSA C22.2 No.3 - M1998(R.2014) - Electrical Features of Fuel-Burning Equipment

**Commonwealth of Massachusetts:** This appliance has been manufactured in accordance with Massachusetts code 248 CMR 5.00. **Approval Code: G1-0319-387** . (<http://license.reg.state.ma.us/public/licque.asp>).

Please contact Archgard Industries Ltd., if you have any questions regarding the certification of this appliance.

## INSTALLATION CODES

This appliance must be installed by a qualified gas appliance installer. The installation must conform with the local codes or, in the absence of local codes, with the current National Fuel Gas Code, ANSI Z223.1/ NFPA 54. Electrical connections and grounding must conform with local codes, or current National Electrical code, ANSI/ NFPA No. 70-1987.

**We recommend that our gas hearth products be installed and serviced by professionals who are certified in the U.S. by the National Fireplace Institute® (NFI) as NFI Gas Specialists.**

## SPECIFICATIONS

	Natural Gas (NG)	Propane (LP)
<b>Manifold Pressure</b>	1.6 - 3.5 in. w.c. (0.4 - 0.9 kPa)	6.4 - 10.0 in. w.c. (1.6 - 2.5 kPa)
<b>Min. Supply Pressure</b>	5 in. w.c. (1.2 kPa)	11.0 in. w.c. (2.8 kPa)
<b>Max Supply Pressure</b>	14 in. w.c. (3.5 kPa)	14.0 in. w.c. (3.5 kPa)
<b>Orifice Size</b>	#37 DMS (2.65 mm dia.)	#52 DMS (1.62 mm dia.)
<b>Nominal Input Rating</b>	20,100 - 30,000 BTU/hr (5.9 - 8.8 kW)	23,000 - 30,000 BTU/hr (6.7 - 8.8 kW)
<b>P.4 Fireplace Efficiency (FE)</b>	<b>SIT 820:</b> 65.94%, <b>SIT 821:</b> 67.80%	
<b>P.4 Steady State Efficiency</b>	<b>SIT 820:</b> 68.49%, <b>SIT 821:</b> 68.49%	
<b>Electrical Rating</b>	120 VAC, 60 Hz less than 2 A.	
<b>Altitude</b>	0-4500 ft (0 - 1372 M)	0 - 4500 ft (0 - 1372 M)
<b>Primary Air Opening</b>	¼" (6 mm) OPEN	½" (13 mm) OPEN

## HIGH ALTITUDE INSTALLATION

When installing this appliance beyond 4500 ft. (1372m) above sea level, the appliance must be properly de-rated and installed according to local codes; in the absence of local codes, with the current National Fuel Gas Code, ANSI Z223.1/ NFPA.

## GAS CONNECTIONS

Before connecting the appliance to the gas supply line, double check that the appliance you have purchased is designed for the gas type you are using. The gas type markings are located on the certification label and also on the appliance's gas valve.

Adequate clearance for proper installation and checking of the gas connections must be provided. **All gas connections must be checked for gas leaks.**

Have your gas supplier or a qualified gas fitter run a gas supply line into the fireplace. The line must be properly sized and fitted according to the installation codes. Immediately upstream of the supply connection, the fitter shall provide an accessible manual shut-off valve and a 1/8" (3mm) NPT plugged tapping accessible for connection to a test gauge. When connecting the supply line to the gas valve, the installer should brace the gas valve to ensure that it is not moved from its bracket. If the valve is not braced when the supply line is connected, the valve may be moved and cause a "break" in the main burner supply line. Such damage is not covered by the manufacturer's warranty.

**CAUTION:** The appliance and its individual shutoff valve must be disconnected from the gas supply piping system during any pressure-testing of that system at test pressures in excess of 1/2 psig (3.5 kPa). The appliance must be isolated from the gas supply piping system by closing its individual manual shutoff valve during any pressure-testing of the gas supply piping system at test pressures equal to or less than 1/2 psig (3.5 kPa). Failure to do so will damage the appliance's gas valve. Such damage is not covered by the manufacturer's warranty.

### **Natural Gas Pressure Settings:**

See specifications table on Page 7 for information on pressures and orifice sizing.

<u>ELEVATION</u>	<u>INPUT RATING</u>
0-4500 ft (0-1372 M)	30,000 BTU/hr (8.8 kW)
4500 ft (1372 M) and above	30,000 BTU/hr (8.8 kW) less 4% per 1000 ft. (305 M)

Please contact your local distributor for the appropriate orifice size you require.

### **Propane Pressure Settings:**

See specifications table on Page 7 for information on pressures and orifice sizing.

<u>ELEVATION</u>	<u>INPUT RATING</u>
0-4500 ft. (0-1372 M)	30,000 BTU/hr (8.8 kW)
4500 ft. (1372 M) and above	30,000 BTU/hr (8.8 kW) less 4% per 1000 ft. (305 M)

Please contact your local distributor for the appropriate orifice size you require

**NOTE: THE INPUT RATING SHOULD ALWAYS BE CHECKED WHEN FIRST RUNNING THIS APPLIANCE.** To do this, reduce the background flow rate, time the meter, light the fireplace and take another reading after 15 minutes of operation. Check with your gas supplier for the gas BTU content at your elevation. Input is the rate of flow multiplied by the heating value of the gas (cubic feet/hour x BTU per cubic feet). Adjust the manifold pressure so that the unit does not operate above the rated input.

**APPLIANCE DIMENSIONS**

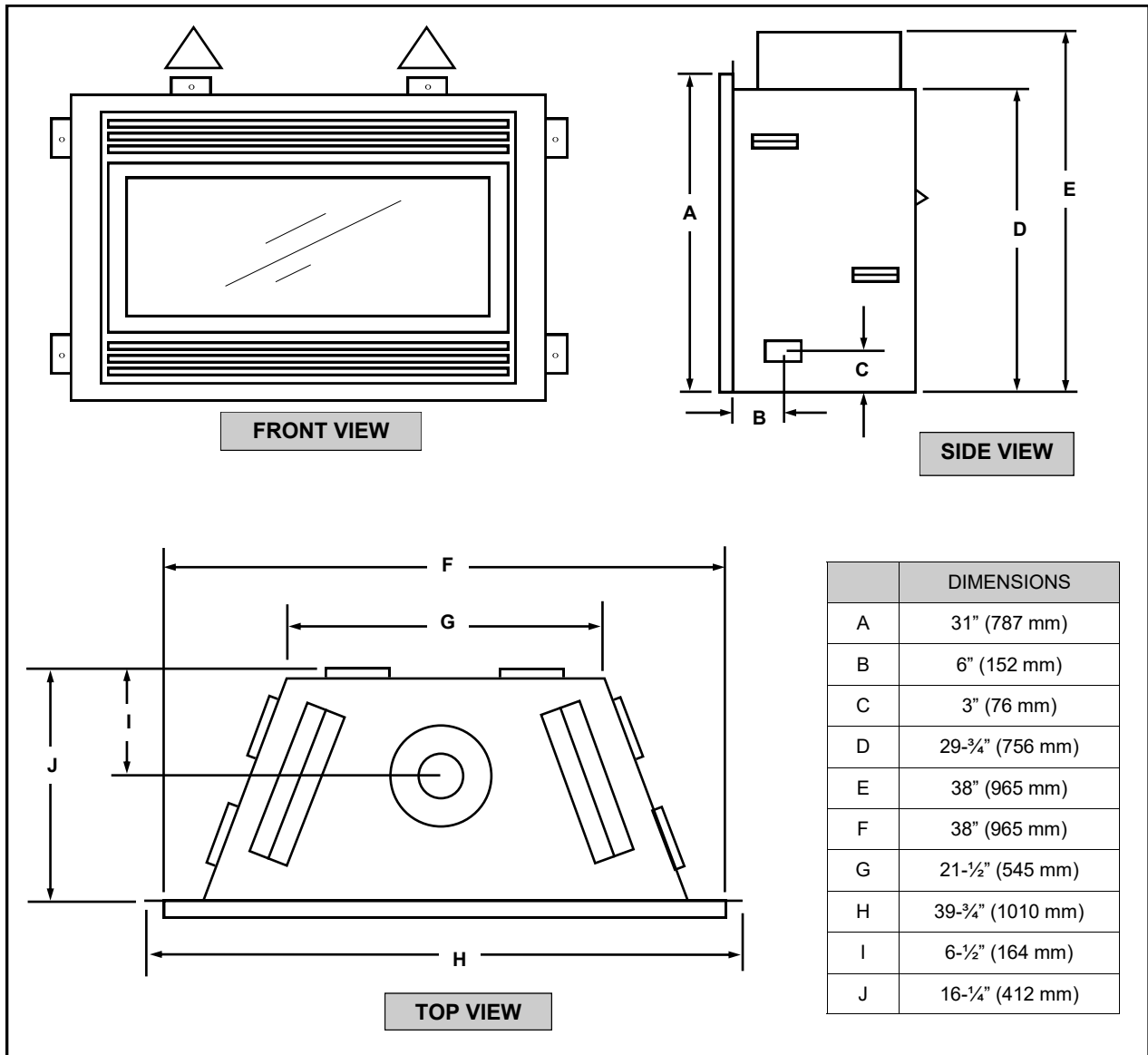

**CLEARANCES TO COMBUSTIBLES**

BACK	0" to stand-offs
SIDES	0" to stand-offs
TOP	0" to stand-offs
BOTTOM	0"
ADJACENT SIDE WALL	1" (25 mm) to side of faceplate
MANTLE	see diagram
VENT	1" (25 mm) to outside side and bottom surface, 2" (50 mm) to outside top surface.

## MANTLE CLEARANCE

**NOTE:**

Low profile wooden crowns and moldings above the unit are not considered as mantles. I.E. 1" (25 mm) or less protrusions on the upper mantle facing are acceptable.

Combustible mantle allowed in shaded area. Mantle extension may be increased 1" (25 mm) for each additional 1" (25 mm) increase in clearance height.

Drywall can be brought up to the edge of the fireplace faceplate and cover the nailing flange. No combustible materials are permitted to cover any of the steel of the face plate

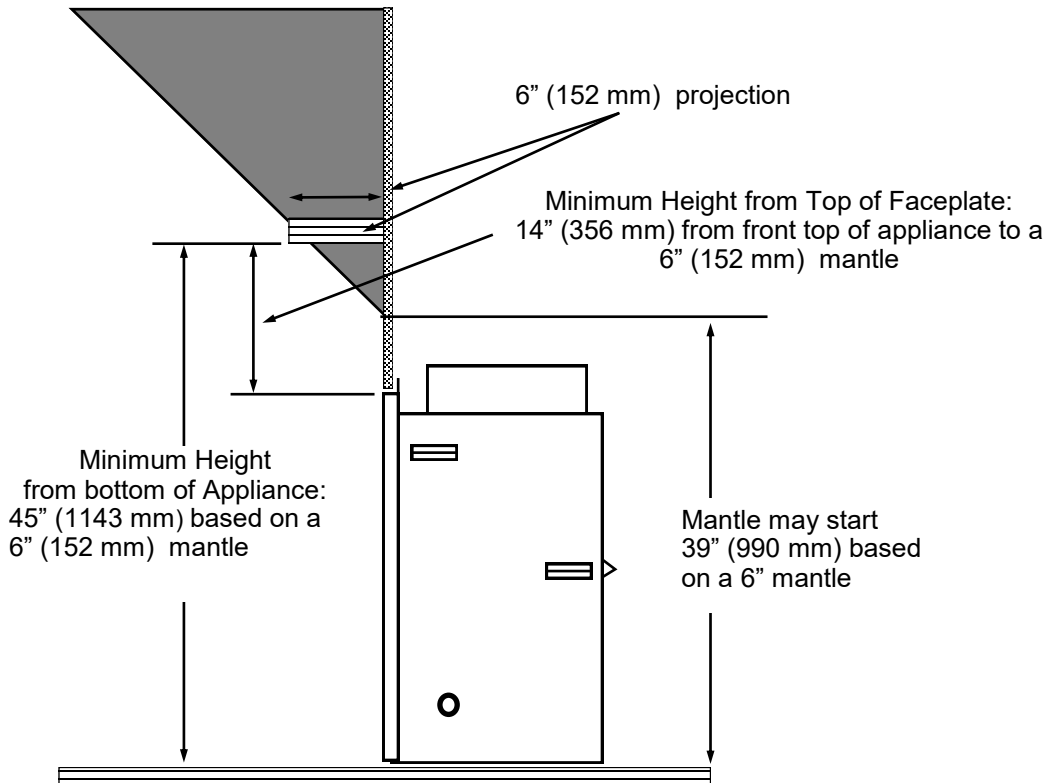

## Heat Sensitive Flooring Materials

Archgard fireplaces are heating products, designed to produce a large amount of radiant and convective heat. The clearances specified above are intended to be minimum clearance distances to combustibles, however, flooring directly adjacent to the minimum hearth clearances may reach temperatures of up to 180°F (82°C) or higher depending on the installation.

Please check with your flooring manufacturer for temperature tolerances as some materials, such as vinyl, tend to be more sensitive to temperatures above average room temperature and may be damaged or warped if exposed to heat.

We recommend testing any flooring material to ensure that it can withstand temperatures generated by this fireplace. If the tolerances of the flooring material are not known or are not capable of withstanding the temperatures generated by this fireplace, install a heat pad constructed of material that is not sensitive to heat, or adjust clearances to heat sensitive materials as shown below.

**Note:** clearances shown are the width of the fireplace door. The dimensions shown are guidelines only and cannot account for all flooring materials. The dimensions shown do not replace the hearth clearances for this product. Always maintain the clearances to combustibles as shown on the previous page.

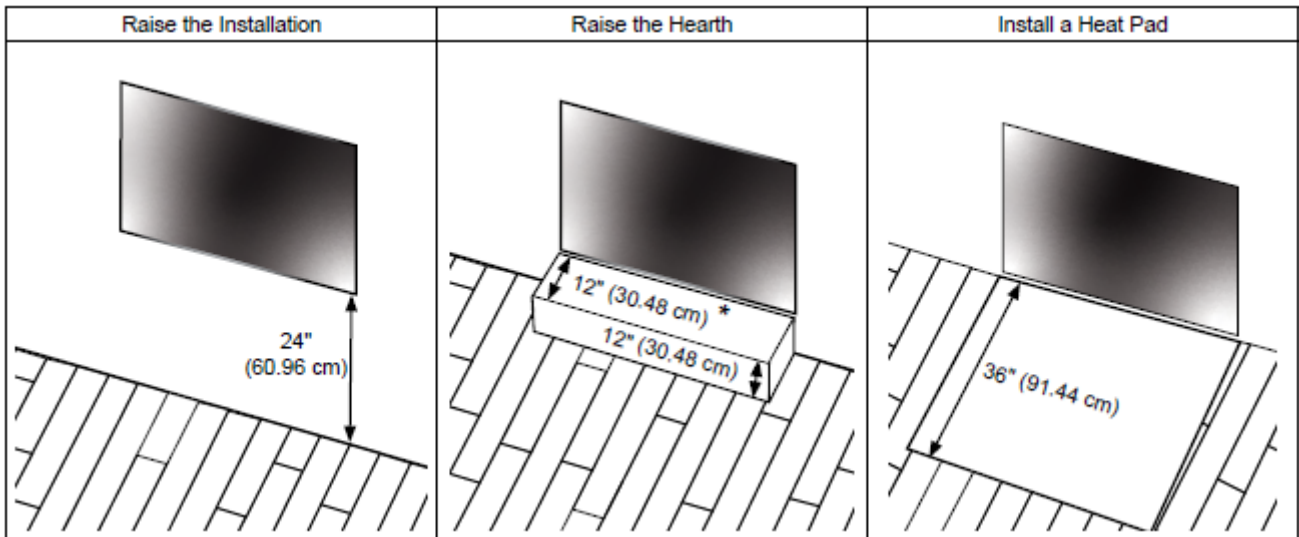

\* Use whichever distance is greater when compared to the hearth clearances.

**FRAMING DIMENSIONS**

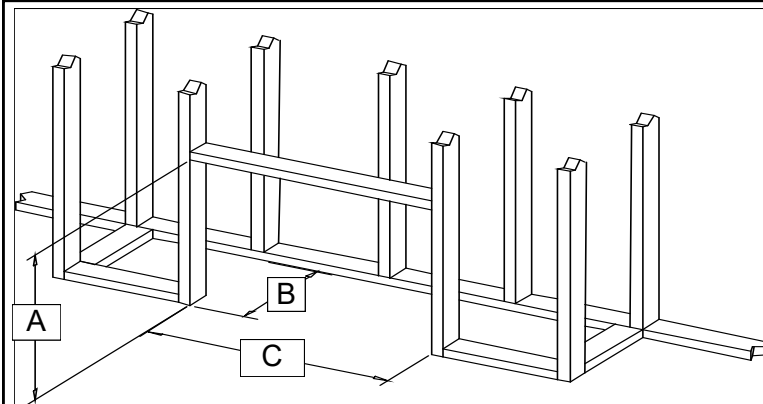

Dimensions	
A	* 38" (965 mm)
B	16-1/4" (412 mm)
C	38" (965 mm)

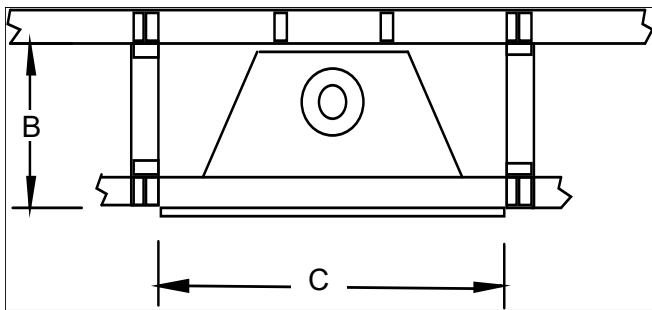

\* This dimension allows the top of the fireplace to slide under. If more rigidity is required, a steel stud may be added to the back of the fireplace top nailing flange after the fireplace is installed.

**CORNER FRAMING**

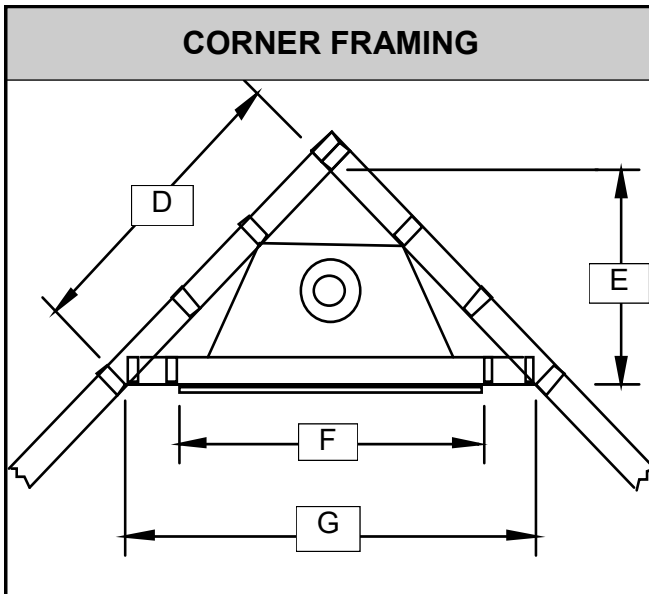

DIMENSIONS	
D	39-1/8" (994 mm)
E	27-5/8" (700 mm)
F	38" (965 mm)
G	55-1/4" (1403 mm)

**TERMINATION FRAMING**

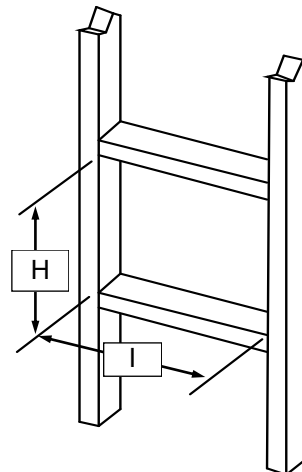

DIMENSIONS	
H	11" (279 mm)
I	10" (254 mm)

**NOTE:** Be sure to include 1/4" (6mm) rise per 12" (305 mm) of horizontal length

## LOCATING GAS FIREPLACE

This appliance must be installed in any location that is free of plumbing, electrical wiring and heating or air conditioning ducts. Select a location that is accessible for venting.

See ALLOWABLE TERMINATION LOCATIONS listed in this manual. **The fireplace may be installed in any location that maintains proper clearances to combustibles, air conditioning ducts, electrical wiring and plumbing. Select a location that is accessible for venting See section Allowable Termination Locations listed in this manual. When the appliance is installed directly on carpeting, vinyl tile or other combustible materials, other than wood flooring, the appliance must be installed on metal or wood panel extending the full width and depth of the appliance.**

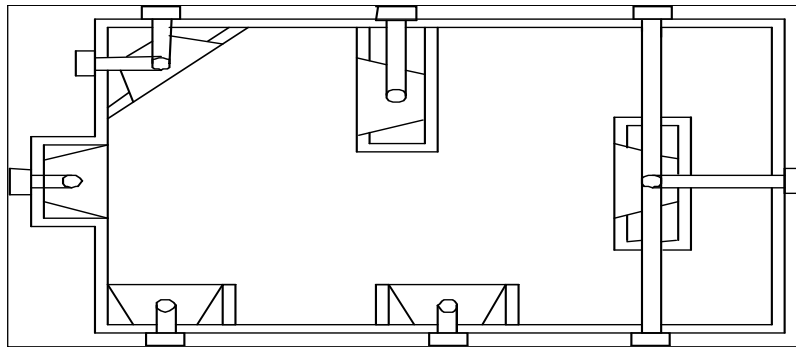

### NOTE:

See venting chart for maximum and minimum vertical / horizontal venting configurations.

## VENT TERMINATION LOCATIONS

ALLOWABLE TERMINATION LOCATIONS and establish a suitable vent termination location.

1. In heavy snowfall areas make sure the vent termination is located where it can not be blocked by snowfall and / or snow from snow-removal equipment.
2. Locate the vent termination away from plants, bushes or any other object near the vent termination that will interfere with or obstruct the airflow around it.
3. DO NOT recess vent termination into walls, sidings or planters.
4. Vent terminations located below 7ft (2.13 M) from grade level or anywhere that it can be a burn hazard to the public, such as patios and balconies, must be protected with an approved termination cage. If using Archgard Venting System, order Part # C-1.

**ALLOWABLE TERMINATION LOCATIONS.**

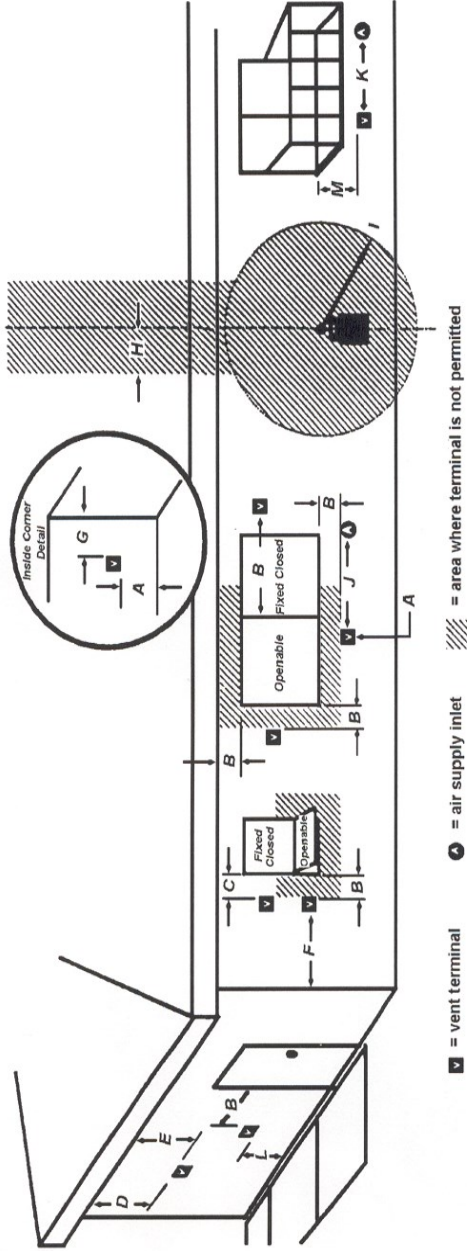

	Canadian Installations (1)	US Installations (2)	Canadian Installations (1)	US Installations (2)
A= Clearance above grade, veranda, porch, deck, or balcony	12 inches (30 cm)	12 inches (30 cm)	12 inches (30 cm)	9 inches (23 cm)
B= Clearance to window or door that may be opened	12 inches (30 cm)	12 inches (30 cm)	6 feet (1.83 m)	3 feet (91 cm) above if within 10 feet (3 m) horizontally
C= Clearance to permanently closed window	*	*	7 feet (2.13 m) +	*
D= Vertical clearance to ventilated soffit located above the terminal within a horizontal distance of 2 feet (61 cm) from the center line of the terminal	*	*	12 inches (30 cm) ++	*
E= Clearance to unventilated soffit	*	*		
F= Clearance to outside corner	*	*		
G= Clearance to inside corner	9" (22.5cm)	9" (22.5cm)		
H= Clearance to each side of center line extended above the meter/regulator assembly	3 feet (91 cm) within a height 15 feet (4.5 m) above the meter/regulator assembly	*		
L= Clearance to service regulator vent outlet	3 feet (91 cm)	*		

J= Clearance to non-mechanical air supply inlet to building or the combustion air inlet or any other appliance				
K= Clearance to a mechanical air supply inlet				
L= Clearance above paved sidewalk or paved driveway located on public property				
M= Clearance under veranda, porch, deck, or balcony				

(1) In accordance with the current CSA B149.1, <i>National Gas and Propane Installation Code</i>	
(2) In accordance with the current ANSI Z223.1/NFPA 54, <i>National Fuel Gas Code</i>	
(+) A vent shall not terminate directly above a side walk or paved driveway that is located between two single family dwellings and serves both dwellings	
(++) Permitted only if veranda, porch, deck, or balcony is fully open on a minimum of two sides beneath the floor.	
(*) For clearances not specified in ANSI Z223.1/NFPA 54 or CSA B149.1, "Clearances shall be in accordance with local installation codes and the requirements of the gas supplier."	

## APPROVED VENT COMPONENTS

The appliance will not function without being connected to a proper venting system. This appliance may only use direct vent system supplied by Archgard Industries or Simpson Dura-Vent direct vent systems with the appropriate adaptor dependent upon the venting guidelines within this manual.

**NOTE: Only the venting components listed below are approved for the 72-DVT30N-2**

PART #	DESCRIPTION
999-DV-TVK3	Archgard Flex Vent Kit with 36" (914 mm) vent length (includes 999-DV-HTC)
999-DV-TVK5	Archgard Flex Vent Kit with 60" (1.52 M) vent length (includes 999-DV-HTC)
999-DV-DV-HTC	Archgard Horizontal termination head only
999-DV-SC	Archgard Safety Cage for Horizontal termination head (999-DV-HTC)
999-DV-VSD	Archgard Vinyl siding deflector
999-DV-SDA	Universal Adapter, Simpson Dura-Vent / Flex
DV-GS	Simpson Dura-Vent venting system

## VENTING CONNECTION

**For best and safe venting performance, here are some general venting rules:**

- Use only Archgard or Simpson Dura-Vent direct vent systems and components.
- **Maintain a minimum of 1" (25mm) clearance to combustibles from the outside surfaces of vertical vents and minimum of 1" (25mm) sides and bottom, and 2" (50mm) from top surfaces of horizontal vents.**
- Observe local code restrictions, if any, regarding the installation of this type of gas appliance.
- **Observe the venting charts given in this manual.**
- Use vent spacers between the inside 4" (101mm) and outside 7" (178mm) vents at 3 ft (915mm) intervals (Archgard Direct Vent System ONLY).
- **Never slope horizontal vents downwards towards the vent termination.**
- **Maintain a minimum ¼" rise (6mm) for every linear foot (305mm) of horizontal vent.**
- Terminate (Horizontally) the vent only with an approved vent termination supplied by Archgard Industries (Part # 999-DV-HTC) or Simpson Dura-Vent Termination Cap.
- Terminate (Vertically) the vent only with Simpson Dura-Vent Vertical Termination Cap.
- **Support horizontal vents every 3 ft (915mm) to prevent sagging.**

**Please strictly follow the venting instructions for optimum performance from the appliance and to avoid sooting and/or service calls.**

**VENTING - RESTRICTOR PLACEMENT**

**RESTRICTOR PLACEMENT FOR ROOFTOP VENTED APPLICATIONS ONLY**

**WARNING:** These restrictors are only to be installed in the vent system if the vent exceeds 10' in vertical height. Restrictor Number 1 below is required if the vent system is between 10'-18' and Restrictor Number 2 below is required if the vent system exceeds 18'. **Installing them under any other circumstances may cause hazardous venting conditions and may result in personal injury, property damage or death.**

**NOT FOR USE IN SIDEWALL VENTED APPLICATIONS**

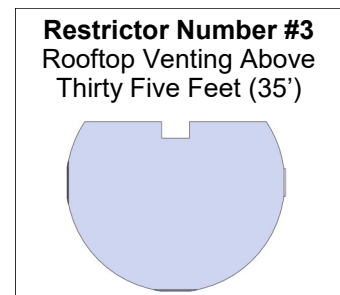
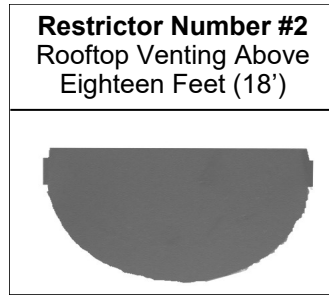
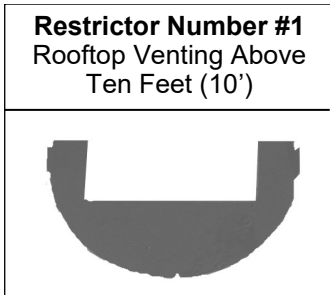

**NOTE:** Vent restrictors are designed to reduce vertical stack action for vent terminations which will reduce the velocity of incoming combustion air and not adversely affect the standing pilot or the efficiency of the appliance.



**VENTING - VERTICAL TERMINATION CHART**

The appliance will not function without being connected to a proper venting system. This appliance may only use direct vent system approved by Archgard, or Simpson Dura-Vent direct vent systems with Archgard 999-DV-SDA adapter.

**VENTING CHART**

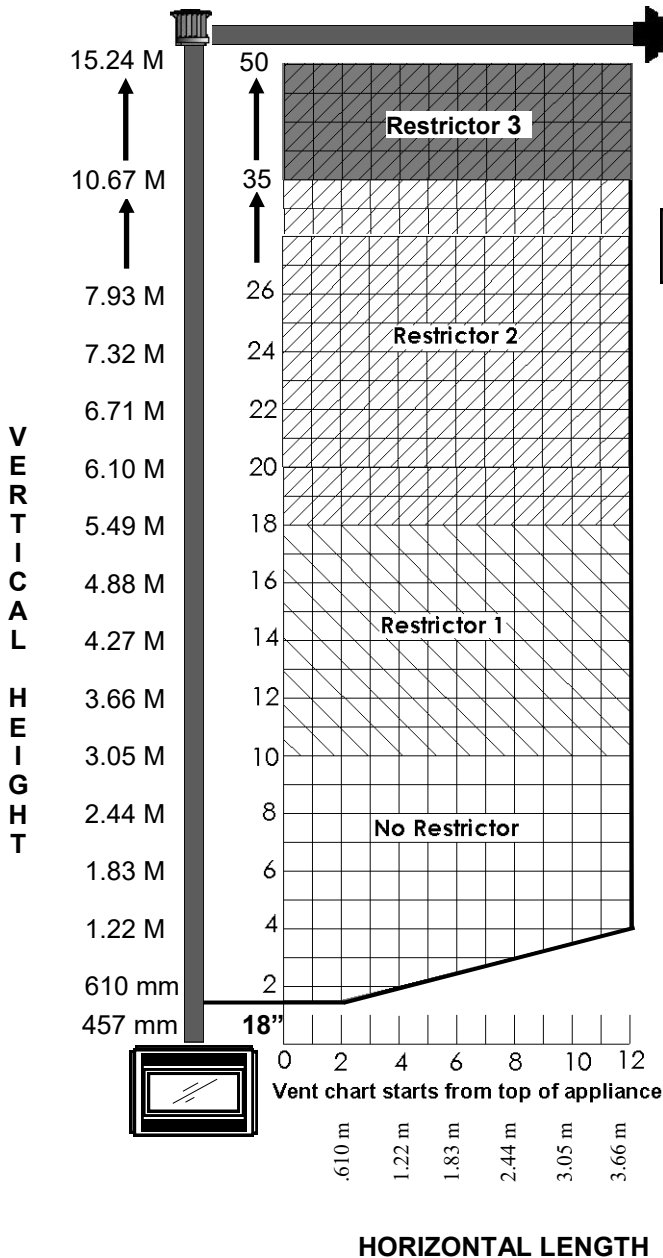

SEE PAGE 14 FOR RESTRICTOR SHAPE & PLACEMENT

NOTE: NO INSTALLATIONS ARE PERMITTED OUTSIDE OF THIS RANGE

- Minimum 18" rise vertical required
- Chart is for one 90° bend, **with a 1/4" (6 mm) minimum vertical rise per running foot** of horizontal length.
- For each additional 90° or two 45°, add one foot of vertical height.
- Maximum three 90° bends, or equivalent allowed in the system.
- Minimum 2 ft (610 mm) straight length between bends.

**VENTING ABOVE ROOF OF THE HOUSE USING A VERTICAL TERMINATION**

Use Simpson Dura-Vent listed direct vent system caps for all vertical vent termination applications (through the roof).

**Please strictly follow the venting instructions for optimum performance from the appliance and to avoid sooting and/or service calls.**

## VENTING - VERTICAL TERMINATION USING SIMPSON DURA-VENT PIPE ONLY

The 72-DVT30N-2 can be vented vertically using Simpson Dura-Vent Direct Vent System. To vent using Simpson Dura-Vent exclusively, you must use the Archgard 999-DV-SDA Adapter and connect the adapter to the top of flue outlet on the Optima 72 gas fireplace.

1. Maintain 1" (25mm) clearance (air space) to combustibles when passing through ceilings, walls, roof, enclosures, attic rafter, or other nearby combustible surfaces. Do not pack air spaces with insulation. Check **Page 16** (Venting Chart) for the maximum vertical rise of the venting system.
2. Set the gas appliance in its desired location. Drop a plumb bob down from the ceiling to the position of the appliance flue exit, and mark the location where the vent will penetrate the ceiling. Drill a small hole at this point. Next, drop a plumb bob from the roof to the hole previously drilled in the ceiling, and mark the spot where the vent will penetrate the roof.

**NOTE:** you may wish to relocate the appliance to avoid cutting load-bearing members.

3. A Firestop spacer must be installed in the floor or ceiling of every level. To install the Firestop spacer in a flat ceiling cut a 10" (254mm) square hole. Frame the hole as shown Fig. 1 and install the firestop.
4. Assemble the desired lengths of pipe and elbows as outlined in the Venting Chart, necessary to reach from the Appliance adaptor (999-DV-SDA). Ensure that all Simpson Dura-Vent and/or flexible gas liners are connected and sealed accordingly.
5. Cut a hole in the roof centered on the small drill hole placed in the roof as outlined in Step 2.
6. The hole should be of sufficient size to meet the minimum requirements for each combustibles of 1" (25mm). Slip the flashing under the shingles (shingles should overlap half of the flashing) as per Fig.2.
7. Continue to assemble pipe lengths and/or flexible gas venting.
8. Ensure vent is vertical and secure the base of the flashing to the roof with roofing nails; slide storm collar over the section and seal with a mastic.
9. Install the vertical termination cap by twist-locking it.

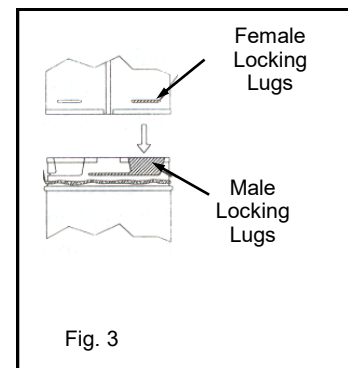
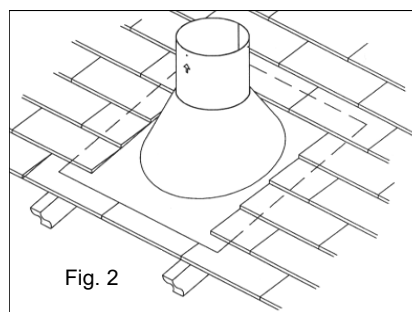
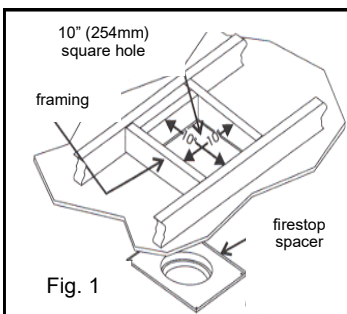

**VENTING - VERTICAL TERMINATION USING SIMPSON DURA-VENT PIPE ONLY**

**NOTE:**

- Galvanized pipe is desirable above the roofline due to its higher corrosion resistance. Continue to add pipe sections throughout the flashing until the height of the vent cap meets the minimum height requirements specified in Fig. 5. or local codes.
- For steep roof pitches, the vertical height must be increased. A poor draft, or down drafting can result in high wind conditions, trees or neighbor's roof lines. In these cases, increasing the height may solve a drafting problem. **REMEMBER** to check that you are within the maximum vertical height restrictions, and are placing the appropriate vent restrictors as outlined in the venting chart within this manual.
- Any storage spaces or closets which the vent must pass through must be enclosed.

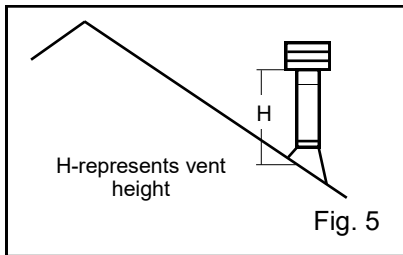

Roof Pitch	Minimum Vent Height	
Flat to 7/12	2 Feet	0.61 Meters
Over 7/12-8/12	2 Feet	0.61 Meters
Over 8/12-9/12	2 feet	0.61 Meters
Over 9/12-10/12	2.5 Feet	0.76 Meters
Over 10/12-11/12	3.25 Feet	1.00 Meters
Over 11/12-12/12	4 Feet	1.22 Meters
Over 12/12-14/12	5 Feet	1.52 Meters
Over 14/12-16/12	6 Feet	1.83 Meters
Over 16/12-18/12	7 Feet	2.13 Meters
Over 18/12-20/12	7.5 Feet	2.29 Meters
Over 20/12-21/12	8 Feet	2.44 Meters

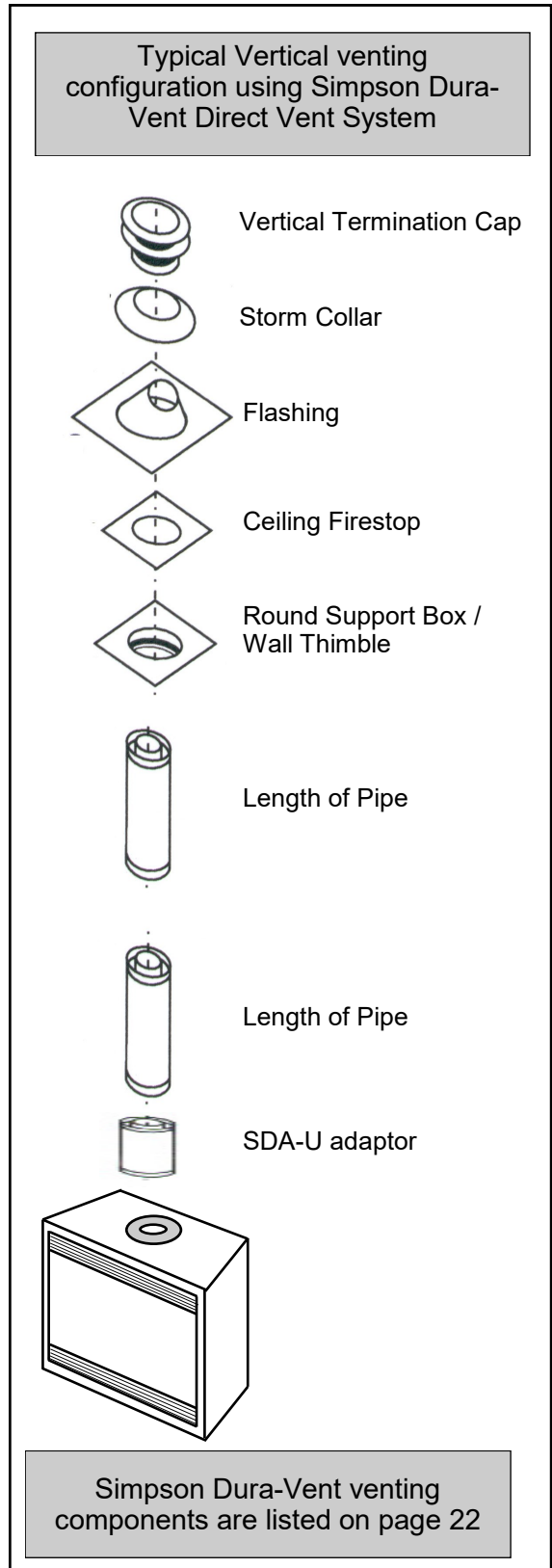

## VENTING - VERTICAL TERMINATION USING FLEX GAS LINER

The 72-DVT30N-2 can be used with Flexmaster Model GA 4" & 7" (101mm & 178mm) vent liners, and terminate through the roof using Simpson Dura-Vent by using an 999-DV-SDA (Adapter, Flex to Simpson Dura-Vent).

- Refer to the venting chart before considering vertical termination.
- Check the Allowable Termination Locations chart within this manual.

## CONNECTING THE 999-DV-SDA ADAPTER TO FLEX & SIMPSON DURA-VENT

### FLEXIBLE PIPE CONNECTIONS

1. The intake pipe must be securely fastened to the appliance and to the terminal and all joints must be secured using a minimum of 3 screws evenly spaced around the pipe.
2. Approximately 1" (25mm) from the end of the 4" (101mm) pipe outlet at the appliance and at the 4" (101mm) terminal inlet, apply a bead of high temperature non-silicone sealant approximately 1/4" (6mm) wide. Slide the 4" (101mm) pipe onto the appliance and secure with 3 screws evenly spaced to the outlet. Repeat the procedure at the terminal inlet.
3. Install a vent spacer between the outer and the inner liner to maintain clearances. Spacers should be installed at every change of direction and every 3 ft. (914mm).
4. See Fig. 1 & 2 to determine where to place the 999-DV-SDA adapter, and connect the 999-DV-SDA adaptor as shown in Fig. 3.
5. Follow all vertical venting directions as outlined in the Vertical termination sections.

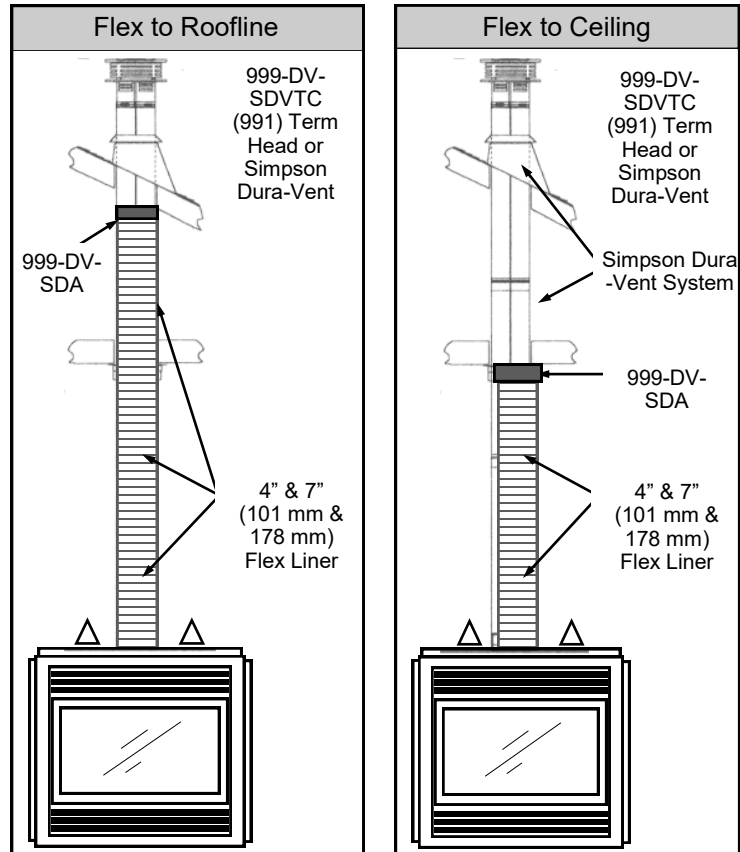

### Connecting the SDA-U Adaptor

Slide the 4" (101mm) flex pipe over the 4" (101mm) section of the 999-DV-SDA adapter, and secure with a bead of mil-pac or other non-silicone sealant (**DO NOT use silicone**) and 3 screws. Repeat the process for the 7" (178mm) liner. Follow with Simpson Dura-Vent Pipe and guidelines for installation as outlined within this manual

Clearance to combustible material and fire-stops must be installed as required by local codes; in the absence of local codes, in accordance with the local enforcing authority.

## VENTING - HORIZONTALLY USING FLEXIBLE DIRECT VENT SYSTEMS

The 72-DVT30N-2 can be vented Horizontally by using the Archgard Direct Vent System of flexible pipe.

PART #	DESCRIPTION
999-DV-TVK3	Flex Vent Kit with 36" (914 mm) vent length (includes 999-DV-HTC)
999-DV-TVK5	Flex Vent Kit with 60" (1.52 M) vent length (includes 999-DV-HTC)
999-DV-TVK10	Flex Vent Kit with 120" (3.05 M) vent length (includes 999-DV-HTC)
999-DV-HTC	Horizontal termination head only
999-DV-SC	Safety Cage for Horizontal termination head (999-DV-HTC)
999-DV-VSD	Vinyl siding deflector

### VENT KIT COMPONENTS (TVK)



7" & 4" flexible liner  
(compressed)



Telescoping  
Thimble



Firestop



Screws



Sealant



Horizontal Termination  
Cap

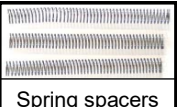

Spring spacers

### VENT ASSEMBLY



4" exhaust vent  
with spring spacers

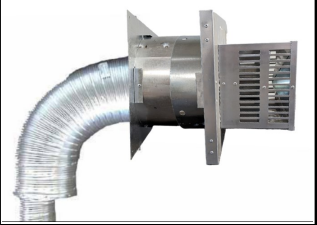

Fully Assembled Flexible  
Direct Vent System

**NOTE:** Pitch the flexible pipe up towards the Horizontal Termination Cap

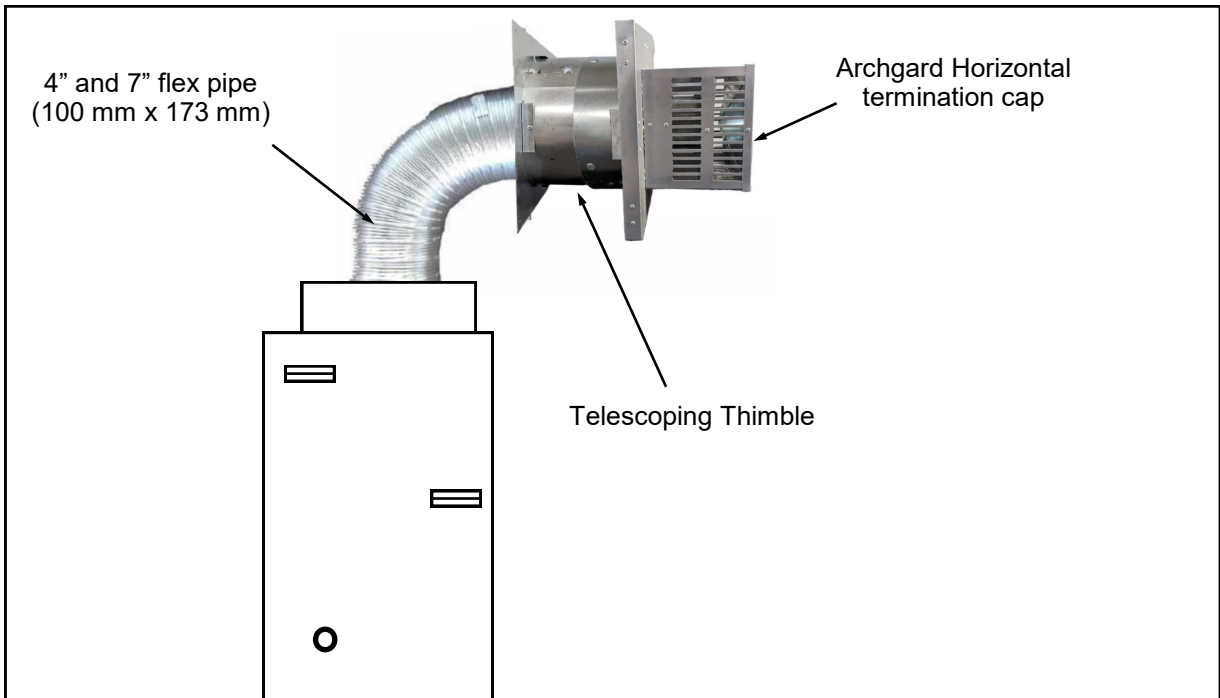

**VENTING - HORIZONTALLY USING FLEXIBLE DIRECT VENT SYSTEMS****INSTALLATION PROCEDURES - ARCHGARD DIRECT VENT (FLEX) SYSTEM**

1. Place the 72-DVT30N-2 in the framing. Locate the centerline of the termination and mark the wall. Cut an 11" x 10" (279mm x 254mm) hole in the wall. NOTE: a 2" (50mm) x 1-1/2" (13mm) around the 7" (178mm) liner is required. See Fig.1 for termination framing.
2. Locate the Horizontal termination head and the 4" (101mm) flexible exhaust pipe, and "DRY" slip the exhaust pipe over the 4" (101mm) exhaust port on the termination head. Un-slip the "DRY" connection and apply high temperature non-silicone sealant to the 4" (101mm) flexible exhaust port and reattach to the 4" (101mm) exhaust connection on the termination head and fasten with three screws on the pre-drilled locations. Repeat this same process with the 7" (178mm) flexible liner.
3. Locate the wall sleeve and cut to the thickness of the wall and slip it through the wall.
4. Locate the Firestop and secure in place with 4 screws.
5. Pull / Straighten the inner 4" (101mm) exhaust pipe to its maximum capacity and "wrap" the spring spacers at every change of direction and every 3ft (914mm) if longer lengths of flexible liner is used. Next pull the 7" (178mm) intake liner over the 4" (101mm) exhaust liner.  
**NOTE:** Take care when "pulling / stretching out the liners; inspect for "breaks" in the liners or in the termination head. Any "breaks" in the venting system will cause poor flame and improper combustion.
6. Slip the assembled liner and termination head through the wall sleeve and make sure the termination cap faces up and fasten the termination head to the wall with 4 screws provided with the kit.  
**NOTE:** If installing the termination head to vinyl or wood siding a Vinyl Siding Deflector (999-DV-VSD) is required. The 999-DV-VSD must be set on top of the horizontal termination cap (fin side out) and then the two screws holding the termination cap are used to secure the termination head and 999-DV-VSD.
7. Apply high temperature non-silicone sealant over the fireplace's inner exhaust collar and slip the 4" (101mm) inner flexible exhaust liner down over it and attach the connection with three screws.
8. Repeat with the 7" (178mm) liner.
9. Apply a bead of all weather sealant (not provided) around the termination head & house to prevent water from entering in.

**NOTES:**

- If installing a Vinyl Siding Deflector (999-DV-VSD) attach the 999-DV-VSD to the front top of the horizontal termination head "fin side out" to ensure the termination head is not recessed into the siding.
- Horizontal sections must be supported to prevent sagging. See vent manufacturer's installation manual for more information - As a general guideline; a flex line should be supported every 2 - 3' (609.6 - 914.4 mm) and rigid pipe should be supported every 4 - 6' (1219.2 - 1828.8 mm)
- Spacers shall be installed at every change of direction and every 3' (914mm) if using additional flexible pipe
- This fireplace must be installed so as to prevent accumulation of condensate in the venting system.

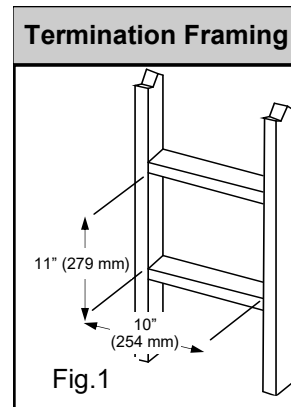

**NOTE:** Be sure to include 1/4" (6mm) rise per foot of horizontal length.

**IMPORTANT:** Do not locate termination head where excessive snow or ice buildup may occur. Check termination head area after every snow fall, and clear if necessary to prevent blockage. If using snow blowers, make sure snow is not directed at the termination head.

## VENTING - HORIZONTALLY USING SIMPSON DURA-VENT DIRECT VENT SYSTEMS

The 72-DVT30N-2 can be vented horizontally using Simpson Dura-Vent Direct Vent System. To vent using Simpson Dura-Vent exclusively, you must use the Archgard 999-DV-SDA Adaptor and connect the 999-DV-SDA adaptor to the top of the Optima 72 as shown in Fig.1.

**NOTE:** Apply high temperature non-silicone sealant to the SDA-U adaptor and the flue connection on the Optima 72. Follow all venting instructions within this manual.

**NOTE:** Call your local Authorized Archgard Dealer to purchase Simpson Dura-Vent Direct Vent Kits and/or venting components.

Minimum components required for horizontal termination using Simpson Dura-Vent:

1 999-DV-SDA (Appliance adaptor)	1 90 Deg. Elbow
1 Horizontal Termination Cap	1 Wall Thimble
1 Length of pipe for top of appliance	1 Length of pipe to suit wall thickness

Measure wall thickness from the back of the fireplace standoffs to the inside mounting surface of the termination cap. If a Vinyl siding standoff is required, measure to the outside surface of the wall without siding and add 2" (50mm).

**NOTE:** The Termination cap must NOT be recessed into siding. Measure wall thickness including finishing straps.

Flat Wall Installation			
Wall Thickness (inches)	Vent Length Required (inches)	Wall Thickness (mm)	Vent Length Required (mm)
4" - 5-1/2"	6"	101 mm - 140 mm	152 mm
7" - 8-1/2"	9"	178 mm - 216 mm	228 mm
10" - 11-1/2"	12"	254 mm - 292 mm	305 mm
9" - 14-1/2"	11" - 14-5/8" Adj. Pipe	228 mm - 368 mm	228 mm - 371 mm
15" - 23-1/2"	17" - 24" Adj. Pipe	381 mm - 597 mm	432 mm - 610 mm

Corner Installations			
Wall Thickness (inches)	Vent Length Required (inches)	Wall Thickness (mm)	Vent Length Required (mm)
3-1/4" - 6-3/4"	11" - 14-5/8" Adj. Pipe	82 mm - 171 mm	228 mm - 371 mm
7-3/4" - 16-1/4"	17" - 24" Adj. Pipe.	197 mm - 412 mm	432 mm - 610 mm
7-1/4" - 8-3/4"	6" + 12" Or 9" + 9"	184 mm - 222 mm	101 mm + 305 mm Or 228 mm + 228 mm
4-1/4" - 5-3/4"	6" + 9"	108 mm - 146 mm	152 mm - 228 mm

### SIMPSON DURA-VENT DIRECT VENT PARTS LIST 6 5/8" x 4" (168mm x 101mm) See your Authorized Archgard Dealer for price and availability.

Part #	Description	Part #	Description	Part #	Description
971	Horiz. Term. Kit Includes; 90° Blk elbow, wall thimble cover, Horiz. square term. Cap, 24" (610 mm) blk pipe and 11"-14" (279 mm x 356 mm) adj. blk pipe.	902	48" (1.22 M) Pipe Length - Galv.	984	Horizontal (Square) Termination Cap
970	Basic Horiz. Term. Kit Includes; 90° blk elbow, wall thimble cover, Horiz. square term. cap.	902B	48" (1.22 M) Pipe Length - Black	985	Horiz. (SQ) Term. Cap. High Wind.
987	Vertical Termination Kit Includes; 0/12- 6/12 pitch adj. flashing, storm collar, low profile term. cap.	911B	11" - 14-5/8" (228 mm x 371 mm) Adj. Pipe Length - Black	982	Snorkel - 14" (356 mm) Rise Term. Cap
908B	6" (152 mm) Pipe Length - Black	917B	17" - 24" (432 mm) x (610mm) Adj. Pipe Length - Black	981	Snorkel - 36" (914 mm) Rise Term. Cap
907B	9" (228 mm) Pipe Length - Black	945	45° Elbow - Galv.	940	Wall Thimble - Support Box
906	12" (305 mm) Pipe Length - Galv.	945B	45° Elbow - Black	941	Cathedral/Ceiling - Support Box
906B	12" (305 mm) Pipe Length - Black	945G	45° Elbow - Swivel - Galv.	3951	Brass Trim for Wall Thimble/Ceiling Sup.
904	24" (610 mm) Pipe Length - Galv.	945BG	45° Elbow - Swivel - Black	963	Firestop Spacer
904B	24" (610 mm) Pipe Length - Black	990	90° Elbow - Galv.	943	Flashing 0/12 - 6/12
903	36" (914 mm) Pipe Length - Galv.	990B	90° Elbow - Black	943S	Flashing 7/12 - 12/12
903B	36" (914 mm) Pipe Length - Black	990G	90° Elbow - Swivel - Galv.	953	Storm Collar
		990BG	90° Elbow - Swivel - Black	950	Vinyl Siding Standoff
		991	Vertical Termination Cap High Wind	988	Wall Strap
		980	Vertical Termination Cap	942	Wall Thimble

## VENTING - HORIZONTALLY USING SIMPSON DURA-VENT DIRECT VENT SYSTEMS

### INSTALLATION PROCEDURES FOR SIMPSON DURA-VENT DIRECT VENT SYSTEM

1. Set the 72-DVT30N-2 in its desired location. Determine if wall studs or roof rafters are in the way when venting system is attached. You may want to adjust the location of the unit to compensate.
2. Simpson Dura-Vent Venting System is designed with special twist-lock connections to connect to the appliance. An Archgard adaptor (999-DV-SDA) is required. The adaptor will allow Simpson Dura-Vent System to be used.
3. Apply a bead of non-silicone sealant inside the outer section of the 999-DV-SDA adaptor. Slip the adaptor over the existing inner and outer flue collar and fasten it to the outer collar only with 3 screws (drill pilot holes first). Level the appliance and fasten it to the framing using nails or screws through the nailing strips.
4. Assemble the desired combination of pipe and elbows to the appliance adaptor and twist lock the pipe.

**NOTE:** Twist-lock procedure: Four indentations, located on the female ends of the pipes and fittings, are designed to slide straight onto the male ends of adjacent pipes and fittings by orientating the four pipe indentations so they match and slide in to the four entry slots on the male ends (Fig. 2.). Push the pipe sections completely together, then twist-lock one section clockwise approximately one quarter turn, until the two sections are fully locked. The female locking lugs will not be visible from the outside, on the pipe or fittings. They may be located by examining the inside of the female ends. Horizontal vent runs **MUST** be supported every three feet (76 mm). Wall straps are available for this purpose.

**NOTE:** Follow venting horizontal venting chart and Allowable Termination locations guidelines.

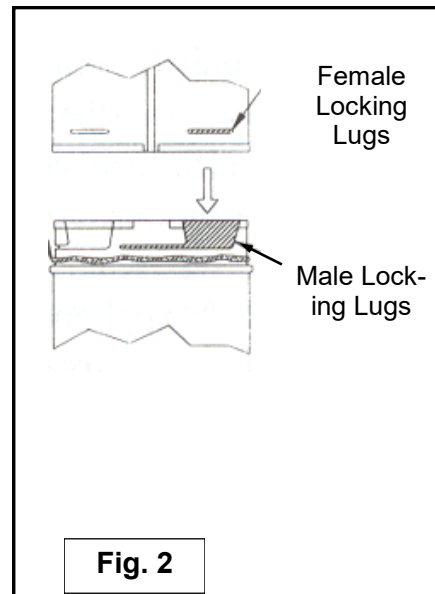
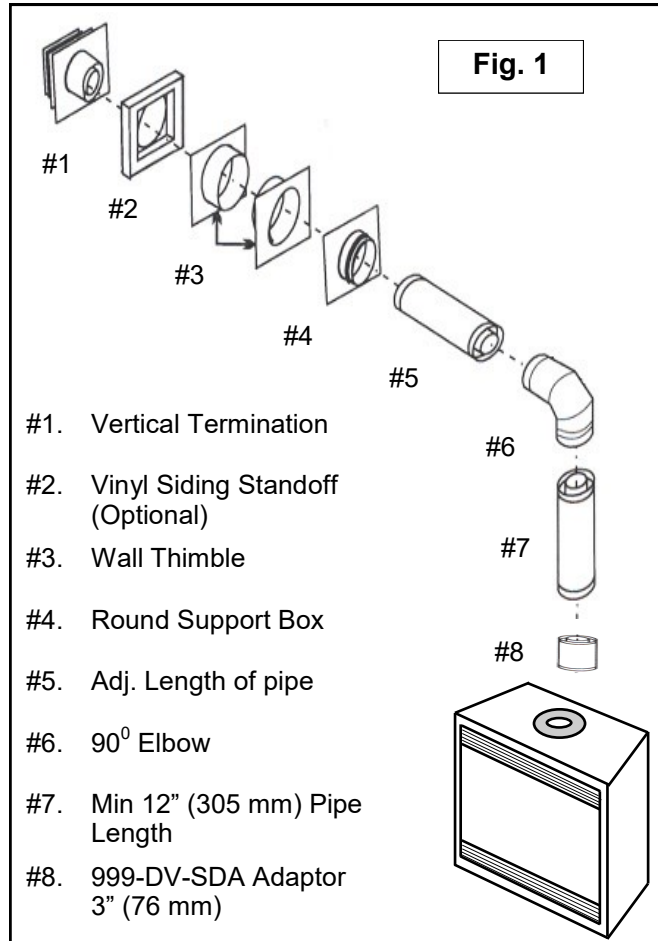

## VENTING - HORIZONTALLY USING SIMPSON DURA-VENT DIRECT VENT SYSTEMS

### INSTALLATION PROCEDURES FOR SIMPSON DURA-VENT DIRECT VENT SYSTEM

5. Mark the wall with an 11" (279mm) x 10" (254mm) hole. See termination framing on page 21. The center of the hole should line up with the centerline of the horizontal pipe. Cut and frame the 11" (279mm) x 10" (254mm) hole in the exterior wall where the vent will be terminated. If the wall being penetrated is constructed of non-combustible material, (i.e. a masonry block, or concrete) a hole with zero clearance is acceptable. NOTES: The horizontal run of vent must be level, or have a 1/4" (6 mm) rise for every 12" (305 mm) of run towards the termination. Never allow the vent to run downward. This could cause high temperatures and may present the possibility of a fire. ALSO: The location of the horizontal vent termination on an exterior wall must meet local and national building codes, and must not be blocked or obstructed. For Allowable Termination Locations see page 13 in this manual.

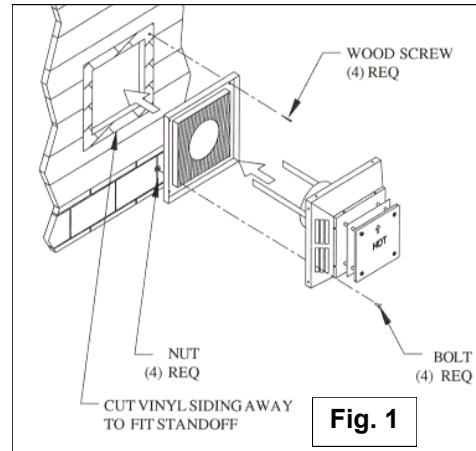

6. Position the Horizontal Vent Termination in the center of the square hole (arrow on the vent cap should be facing UP), and run a bead of non-hardening non-silicone sealant around the outside edges of the termination, so as to make a seal between the termination and the wall. Finish attaching the termination cap to the wall with the four wood screws provided with the termination cap. NOTE: The four wood screws provided should be replaced with the appropriate fasteners for stucco, brick, concrete or other types of siding. For buildings with VINYL SIDING, a Vinyl Siding Standoff should be installed between the vent cap and the exterior wall. Attach the Vinyl Siding Standoff to the Horizontal Termination Cap by bolting the flat portion of the Vinyl Siding Standoff (Fig.1.) so that an air space will exist between the wall and the Vent Termination.

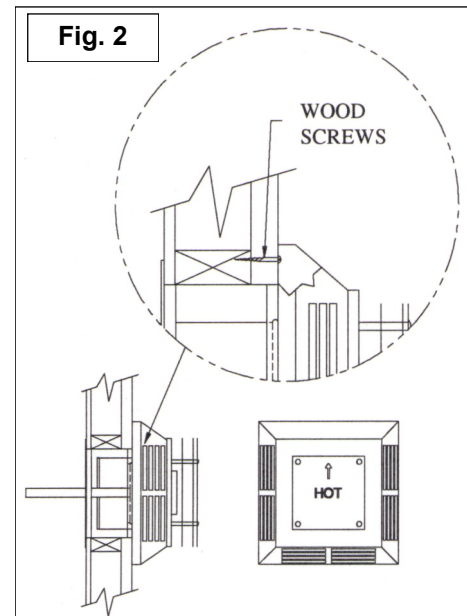

7. Locate and slide the Wall Thimble Cover over the vent pipe.
8. Slide the appliance and vent assembly towards the wall, carefully inserting the vent pipe into the vent cap assembly. It is important that the vent pipe extend into the vent cap sufficient distance so as to result in a minimum pipe overlap of 1-1/4" (31 mm). Secure the connection between the vent pipe and the vent cap by attaching the two sheet metal strips extending from the vent cap assembly into the outer wall of the vent pipe. Use the two sheet metal screws provided to connect the strips to the pipe section. Bend any remaining portion of the sheet metal strip back towards the vent cap, so it will be concealed by the Wall Thimble Cover. (Fig. 2.)

9. Slide the Wall Thimble Cover up to the wall surface and attach to the wall with wood screws. (Fig. 3.)

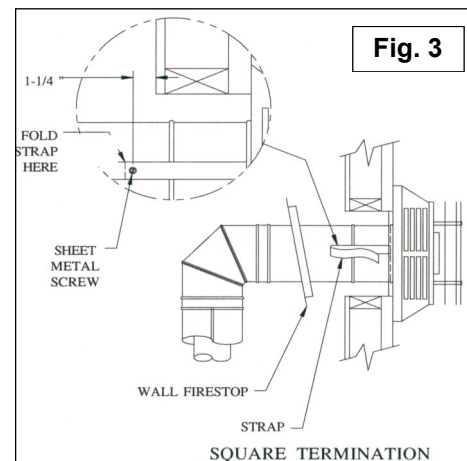

**NOTE:** Apply high temperature sealant to inner and outer pipe on every Simpson Dura-Vent twist-lock joint.

## ELECTRICAL CONNECTIONS, FAN SYSTEM

**WARNING:** Before starting, make certain the power supply is turned OFF.

The 72-DVT30N-2 comes complete with a temperature activated fan and rheostat installed and wired to an internal junction box. The heat sensor is factory set to close the circuit to the fan speed control at 110° F (43° C) and will turn off the fan when the temperature falls below 80° F (27° C).

Have a qualified electrician run a 120VAC supply line to the lower left side of the fireplace before installing the appliance. There should be 18" (460mm) of the supply line free for ease of connection to the appliance. Connect the electrical supply line to the appliance at the same time the gas line is being connected to the appliance.

**NOTE:** This appliance, when installed, must be electrically grounded in accordance with local codes or, in the absence of local codes, with the **National Electrical Code, ANSI/NFPA 70.**

Open the bottom (louver) grill and undo the 2 screws holding the control panel. Run the line into the left side of the appliance through the hole in the rear of the junction box and hold with a standard 7/8" (22 mm) clamp. Connect the (black) supply conductor to the free black conductor from the speed controller with a marrette type wire connector. Connect the 'neutral' white supply conductor to the free white conductor from the fan with a marrette-type wire connector. Connect the 'ground' (green or bare) conductor to the ground screw in the junction box. Replace the junction box cover the control panel and fasten with the 2 screws. A BX connector or other suitable approved wiring strain relief must be installed on the junction box.

## WIRING DIAGRAM

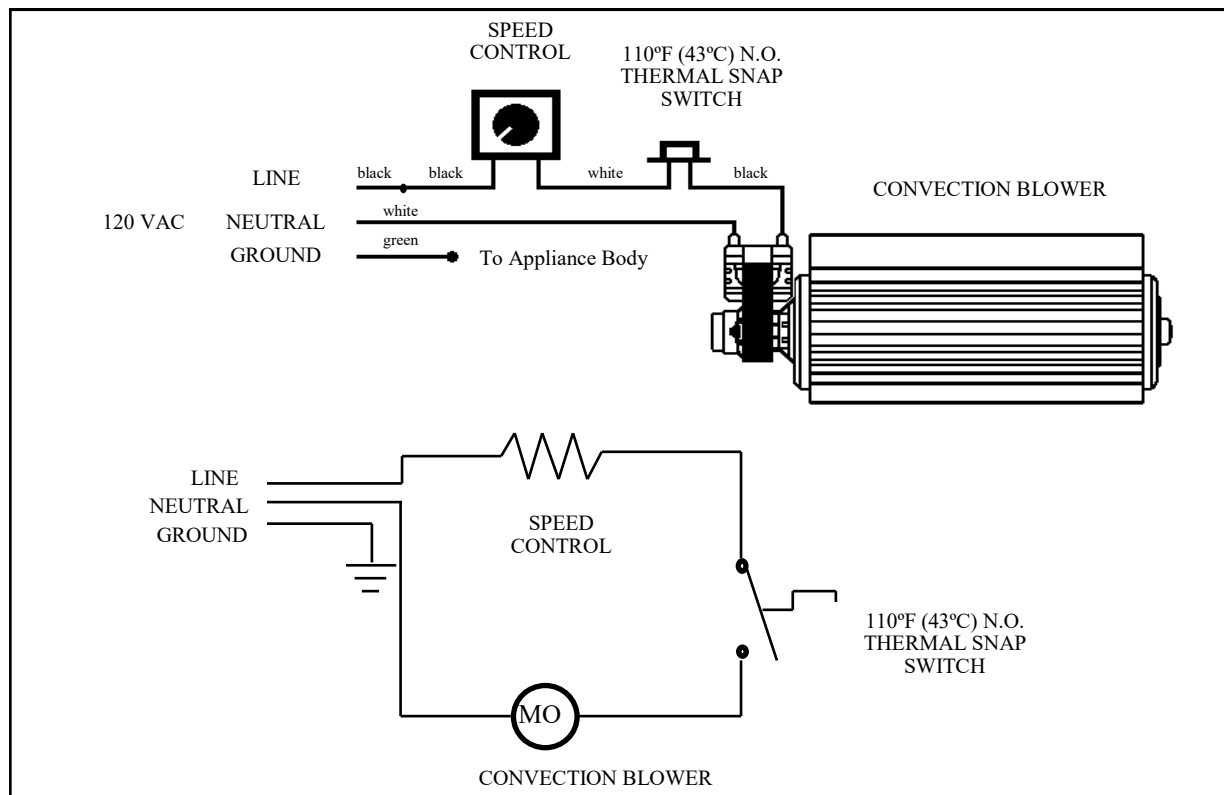

**LOG PLACEMENT**

The Archgard pan burner and fiber logs are designed to give a realistic fire package, and are created to look the same as the day they were originally installed. Care must be given when first installing the logs, and if removed for servicing, as they can be damaged or broken if not handled properly.

After opening the log set package, inspect the logs to ensure that no damage has occurred inside the package. Please report any damage immediately to your Authorized Archgard Dealer.

Gas and vent connections must be made before installing the logs and embers on the pan burner.

**NOTE:** Improper placement of logs and/or embers may cause sooting on the internal parts and glass, and will not be covered under warranty. Do not use broken or damaged logs.

**WARNING:** Failure to position the parts in accordance with these diagrams or failure to use only parts specifically approved with this appliance may result in property damage or personal injury.

The pan burner has pins and rests to accept the logs. Locate the grate and embers and place them on the pan burner as shown. Refer to the pictured instructions on the following pages that will show how to place the logs. The bottom of each log has a 1 or 4 digit code that can be used as a reference to help locate the correct log.

**IMPORTANT:** Pins & holes must be aligned with logs & burner.

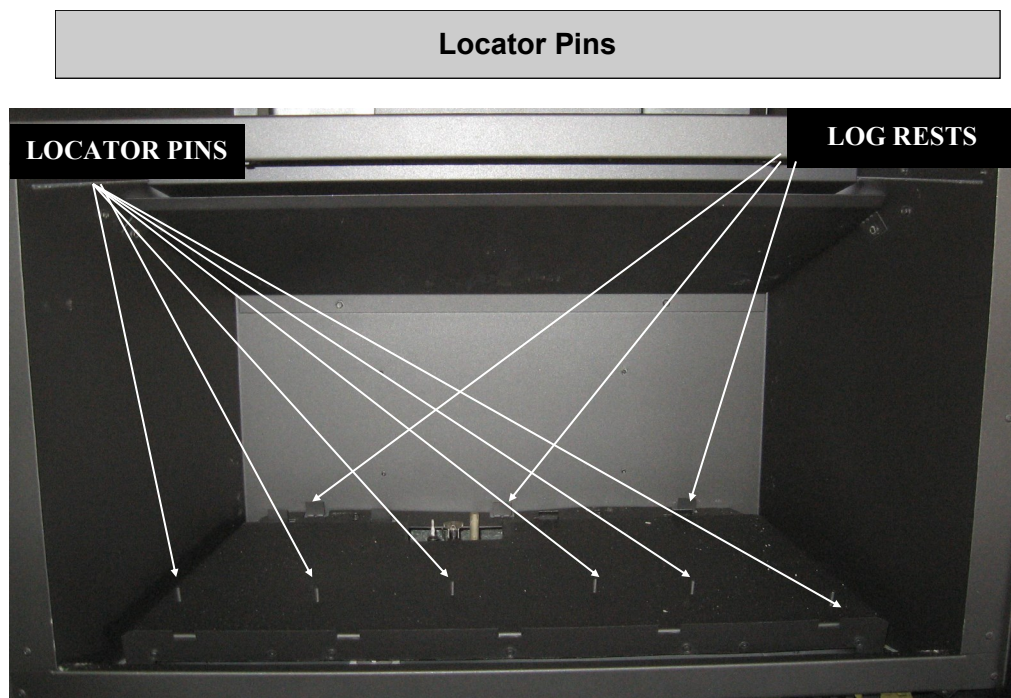

**NOTE:** Installing the fiber logs in any other position other than shown will result in flame impingement causing sooting of the logs, brick liner and ceramic glass viewing area.

## LOG PLACEMENT... Continued

**Step 1.** Locate Log with 7207 stamped on the bottom and place it as shown.



**Step 2.** Locate Log with 7201 stamped on the bottom and place it as shown.



## LOG PLACEMENT... Continued

**Step 3.** Locate Log with 7203 stamped on the bottom and place it at the rear as shown.



**Step 4.** Locate Log with 7202 stamped on the bottom and place it on the burner as shown.



## LOG PLACEMENT... Continued

**Step 5.** Locate Log with 6 stamped on the bottom and place it on the front pins as shown.



**Step 6.** Locate Log with no number stamped on the bottom and place it as shown.



## LOG PLACEMENT... Continued

**Step 6.** Locate Log with 7205 stamped on the bottom and place it on the front pins as shown.



**Step 7.** Place black embers around logs as shown , do not cover the holes in the burner.

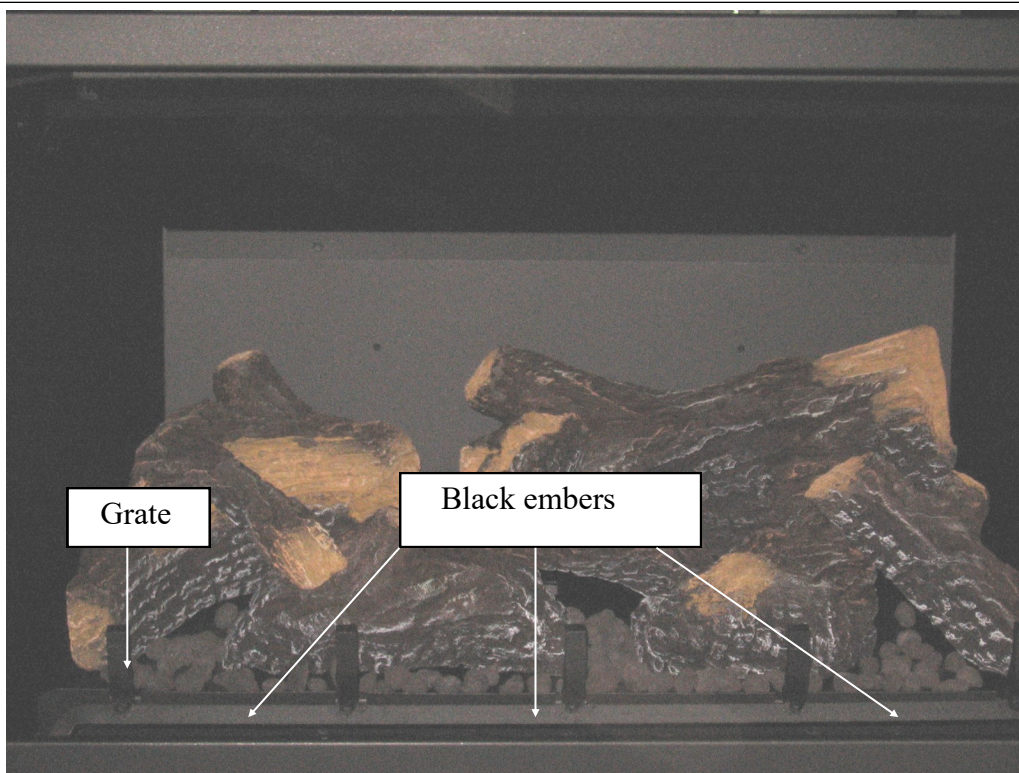

**Step 8.** Locate the grate and place it as shown.

## OPTIONAL BRICK PLACEMENT

The Archgard brick and reflective glass panels offer a variety of looks to customize your fireplace and are purchased separately. Care must be given when first installing the bricks, and if removed for servicing, as they can be damaged or broken if not handled properly.

After opening the brick or reflective glass panels set package, inspect to ensure that no damage has occurred inside the package. Please report any damage immediately to your Authorized Archgard Dealer.

Gas and vent connections must be made before installing the brick and reflective panels.

**NOTE:** Improper placement of panels may cause sooting on the internal parts and glass, and will not be covered under warranty. Do not use broken or damaged logs.

**WARNING:** Failure to position the parts in accordance with these diagrams or failure to use only parts specifically approved with this appliance may result in property damage or personal injury.

The fireplace has panel mounting brackets already in place. Remove the brackets before installing the panels. Locate the brick or reflective panels and place them in the firebox as shown. Refer to the pictured instructions on the following pages that will show how to place the panels.

### Rear Brick Panel Placement as Shown

1st Panel



**NOTE:** Installing the panels in any other position other than shown will result in flame impingement causing sooting of the logs, brick liner and ceramic glass viewing area.

## OPTIONAL BRICK PLACEMENT

### Right Brick Panel Placement as Shown



**NOTE:** Installing the panels in any other position other than shown will result in flame impingement causing sooting of the logs, brick liner and ceramic glass viewing area.

Left Brick Panel Placement as Shown

4th Panel



**NOTE:** Installing the panels in any other position other than shown will result in flame impingement causing sooting of the logs, brick liner and ceramic glass viewing area.

**OPTIONAL WALL SWITCH OR THERMOSTAT**

If a wall mounted switch or a wall mounted thermostat is desired, Archgard recommends that the device be wired as shown in Fig 1.

**NOTE:** Archgard Industries does not manufacture or sell any type of wall switch or wall thermostat and will not extend warranty to them.

Thermostat / wall switch wire table Recommended Maximum Lead Length for two wire	
Wire Size	Max. Length
14 GA.	50 Ft. (15.24 M)
16 GA.	32 Ft. (9.75 M)
18 GA.	20 Ft. (6.09 M)
20 GA.	12 Ft. (3.65 M)
22 GA.	9 Ft. (2.74 M)

**VALVE CONNECTION FOR MILLIVOLT VALVE**

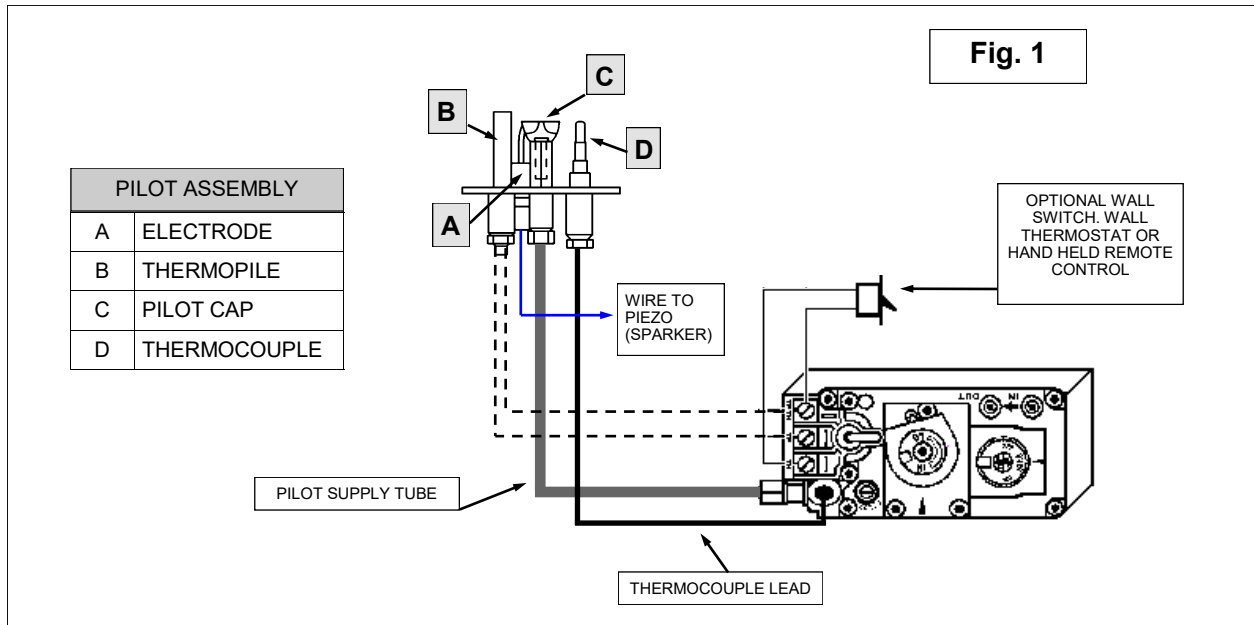

**FIRST FIRE**

When operated for the first few times, the appliance will emit some odor and fumes. This is due to the heat from the appliance evaporating the oils and solvents used in fabricating the appliance. Close off the room to the rest of the house and open all windows. Keep the room well ventilated as smoke alarm may sound. Run the appliance for at least 6 hours at maximum setting with blower set to "OFF" to allow paint to cure (after the installer has checked to ensure the fan is operational). Smoke and fumes caused by the curing process may cause discomfort to some individuals.

**LIGHTING INSTRUCTIONS - CAUTION**

**WARNING :** If you do not follow these instructions exactly, a fire or explosion may result causing property damage, personal injury or loss of life. Do not operate the appliance with the glass front removed, cracked or broken. Replacement of broken glass should be done by a licensed or qualified service person.

This appliance has a pilot which must be ignited using the sparker located next to the appliance valve controls. When lighting the pilot, follow the start-up procedures **exactly**. See next page or rating plate for complete lighting instructions.

1. BEFORE LIGHTING, smell all around the appliance area for gas. Be sure to smell next to the floor, because some gases are heavier than air and will settle on the floor.
2. IF YOU SMELL GAS, follow the instructions on the front cover of this manual.
3. Use only your hand to push in or turn the gas control knob. Never use tools. If the knob will not push in or turn by hand, don't try to repair it. Call a qualified service technician. Force or attempted repair of gas control knob may result in a fire or explosion.
4. Do not use this appliance if any part has been under water. Immediately call a qualified service technician to inspect the appliance and to replace any part of the control system and any gas control which has been under water.

## FINAL INSTALLATION CHECK

Each Archgard Gas Fireplace is checked and tested at the factory prior to being packaged, shipped to our dealers, and finally installed in your home. Archgard recommends that, before leaving this unit with the customer, the installer must ensure that the appliance is firing correctly, and that the electrical system is in working order. **This will include:**

1. Performing leak tests of supply line, gas control valve, supply line from gas control valve and pilot assembly.
2. Clocking the appliance to ensure the correct firing rate (see rating plate or page 7 of this manual).
3. If required, adjusting the primary air to burner to ensure that the flame does not carbon or soot. (see rating plate or page 7 of this manual)
4. Check for proper operation including correct drafting.
5. The FAN system should be turned ON for a minimum of 15 minutes to ensure the fan, rheostat and fan sensor are all working correctly. After the system has been checked, and confirmed that the fan components are in working order, turn the fan system OFF and refer to the instructions for FIRST FIRE located in this manual.

As a reminder, a TAG is attached to all of our gas fireplaces. This TAG is located at the gas control valve. (See Fig 1).

Fig 1.

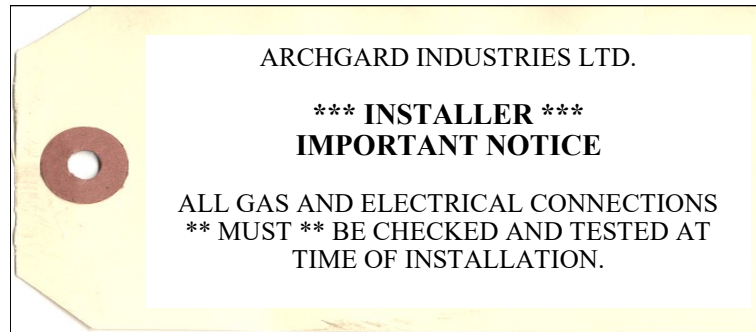

**Any alteration to the product that causes carboning or sooting that results in any damage or requires cleaning is not the responsibility of the manufacturer.**

## INITIAL OPERATION

1. Check that the appliance is properly vented and connected to the gas supply.
2. Check that the logs and branches are properly placed.
3. Check that all external parts, such as grills, door and faceplate are properly attached and fastened.
4. Do not operate this appliance with broken or cracked glass doors or without the door (s) in its correct (and latched) position. Do not use abuse the glass by either striking or slamming shut.
5. Check that there are no fingerprints left on gold surfaces or glass panels, as high temperature can bake these prints on permanently.

## LIGHTING INSTRUCTIONS ON RATING PLATE







FOR YOUR SAFETY READ BEFORE LIGHTING  
POUR VOTRE SÉCURITÉ VEUILLEZ LIRE AVANT L'ALLUMAGE

**WARNING: If you do not follow these instructions exactly, a fire or explosion may result causing property damage, personal injury or loss of life.**

**AVERTISSEMENT: Quiconque ne respecte pas à la lettre les instructions dans la présente notice risque de déclencher un incendie ou une explosion entraînant des dommages, des blessures ou la mort.**

- A. This appliance has a pilot which must be lighted by manual spark igniter. When lighting the pilot, follow these instructions exactly.
- B. BEFORE LIGHTING smell all around the appliance area for gas. Be sure to smell next to the floor because some gas is heavier than air and will settle on the floor.
- WHAT TO DO IF YOU SMELL GAS
- Do not try to light any appliance.
  - Do not touch any electrical switch; do not use any phone in your building.
  - Immediately call your gas supplier from a neighbor's phone. Follow the gas supplier's instructions.
  - If you cannot reach your gas supplier, call the fire department.
- C. Use only your hand to push in or turn the gas control knob. Never use tools. If the knob will not push in or turn by hand, do not try to repair it, call a qualified service technician. Force or attempted repair may result in a fire or explosion.
- D. Do not use this appliance if any part has been under water. Immediately call a qualified service technician to inspect the appliance and to replace any part of the control system and any gas control which has been under water.
- A. Cet appareil est muni d'une veilleuse qui doit être allumée par allumeur manuel. Respectez les instructions ci-dessous à la lettre.
- B. AVANT D'ALLUMER la veilleuse, reniflez tout autour de l'appareil pour déceler une odeur de gaz. Reniflez près du plancher, car certains gaz sont plus lourds que l'air et peuvent s'accumuler au niveau du sol.
- QUE FAIRE SI VOUS SENTEZ UNE ODEUR DE GAZ:
- Ne pas tenter d'allumer d'appareil
  - Ne touchez à aucun interrupteur; ne pas vous servir des téléphones se trouvant dans le bâtiment
  - Appelez immédiatement votre fournisseur de gaz depuis un voisin. Suivez les instructions du fournisseur.
  - Si vous ne pouvez rejoindre le fournisseur, appelez le service des incendies.
- C. Ne pousser ou tourner la manette d'admission du gaz qu'à la main. Ne jamais employer d'outil à cette fin. Si la manette reste coincée, ne tentez pas de la réparer; appelez un technicien qualifié. Quiconque tente de forcer la manette ou de la réparer peut provoquer une explosion ou un incendie.
- D. N'utilisez pas cet appareil s'il a été plongé dans l'eau, même partiellement. Faites inspecter l'appareil par un technicien qualifié et remplacez toute partie du système de contrôle et toute commande qui ont été longés dans l'eau.

### LIGHTING INSTRUCTIONS INSTRUCTION D'ALLUMAGE

- STOP! Read the safety information above on this label.
- Set the wall switch to "OFF".
- Turn off all electric power to the appliance.
- Open lower louvers or remove trim and barrier screen.
- Press slightly and turn the control knob clockwise  to the "OFF" position. Open gas isolation valve.
- Wait 5 minutes to clear out any gas. Then smell for gas, including near the floor. If you smell gas, STOP! and follow "B" in the safety information above (and to the left) on this label. If you do not smell gas, go to the next step.
- Find pilot. It is adjacent to the burner and may be partially concealed by a decorative cover.
- Press slightly and turn control knob counterclockwise  to "PILOT". Depress knob and light pilot by repeatedly pressing the igniter. Once flame is established, hold knob depressed for approximately 30 seconds. Release knob. If pilot should go out, repeat steps 3 to 8.
  - If the knob does not pop up when released, stop and immediately call your service technician or gas supplier.
  - If the pilot will not stay lit after several tries, turn the gas control knob to "OFF" and call your service technician or gas supplier.
- Turn the control knob counterclockwise  to the "ON" position.
- Set the wall switch to "ON".
- Turn on all electric power to the appliance.
- Close louver or replace trim and the barrier screen.
- ARRÊTEZ! Lisez les instructions de sécurité sur la portion supérieure (à gauche) de cette étiquette.
- Réglez le commutateur à distance sur "OFF".
- Coupez l'alimentation électrique de l'appareil.
- Ouvrez persiennes inférieurs ou porte d'accès.
- Appuyez légèrement et tournez le bouton de commande dans le sens horaire  à la position "OFF". vanne d'isolement de gaz ouverte.
- Attendre cinq (5) minutes pour laisser échapper tout le gaz. Reniflez tout autour de l'appareil, y compris près du plancher, pour déceler une odeur de gaz. Si vous sentez une odeur de gaz, ARRÊTEZ! Passez à l'étape B des instructions de sécurité sur la portion supérieure (à gauche) de cette étiquette. S'il n'y a pas d'odeur de gaz, passez à l'étape suivante.
- Trouver pilote. Il est adjacent au brûleur et peut être partiellement masqué par un couvercle décoratif.
- Appuyez légèrement et tournez le bouton de commande vers la gauche  pour "PILOT". Enfoncez le bouton et la veilleuse en appuyant plusieurs fois sur la allumeur. Une fois que la flamme est établie, maintenez le bouton enfoncé pendant environ 30 secondes. bouton de sortie. Si pilote doit sortir, répétez les étapes 3 à 8.
  - Si la manette ne se soulève pas d'elle-même lorsqu'on la relâche, arrêter et appeler immédiatement un technicien qualifié ou le fournisseur de gaz.
  - Si la veilleuse ne reste pas allumée après plusieurs tentatives, réglez la manette d'admission du gaz à la position OFF et appelez un technicien qualifié ou le fournisseur de gaz.
- Tournez le bouton de commande dans le sens antihoraire  à la position "ON".
- Allumez l'alimentation électrique de l'appareil.
- Réglez le commutateur à distance sur "ON".
- Persienne fermée ou porte d'accès.

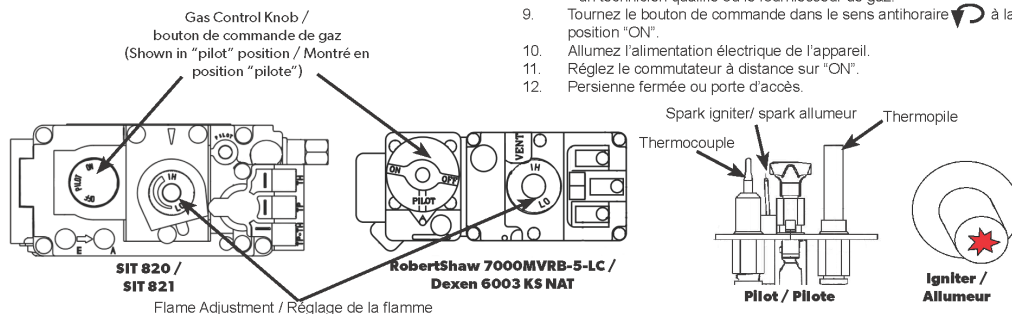

### TO TURN OFF GAS TO APPLIANCE COMMENT COUPER L'ADMISSION DE GAZ DE L'APPAREIL

- Set the wall switch to "OFF".
- Turn off all electric power to the appliance if service is to be performed.
- Open lower louvers or remove trim.
- Press slightly and turn control knob clockwise  to "OFF". Do not force. Close gas isolation valve.
- Close lower louvers or replace trim.
- Réglez le commutateur à distance sur "OFF".
- Coupez l'alimentation électrique de l'appareil s'il faut procéder à l'entretien.
- Ouvrez persiennes inférieurs ou porte d'accès.
- Appuyez légèrement et tournez le bouton de commande dans le sens horaire  à la position "OFF". vanne d'isolement de gaz à proximité
- Persienne fermée ou porte d'accès.

## GLASS DOOR REMOVAL

**WARNING:** Do not operate appliance with the glass front removed, cracked or broken. Replacement of the glass should be done by a licensed or qualified service person. Do not abuse the glass doors, such as striking or slamming shut.

Only doors certified with the appliance shall be used.

**WARNING:** Do not attempt to remove the glass door when the appliance is hot.

1. Remove the top louver by pulling the entire louver assembly towards you.
2. Open bottom hinged louver .
3. Locate the 2 buckle latches under the door frame (Fig.1) and pull down the lever on the back of the latches to release them.
4. Unhook the latches from the bottom of the door and swing the bottom of the door towards you then lift up on the whole door to unhook the top of door. Carefully remove the door and put it away at a safe location where it cannot be scratched or damaged.

### Replacing the Glass Door

Reverse the above procedure.

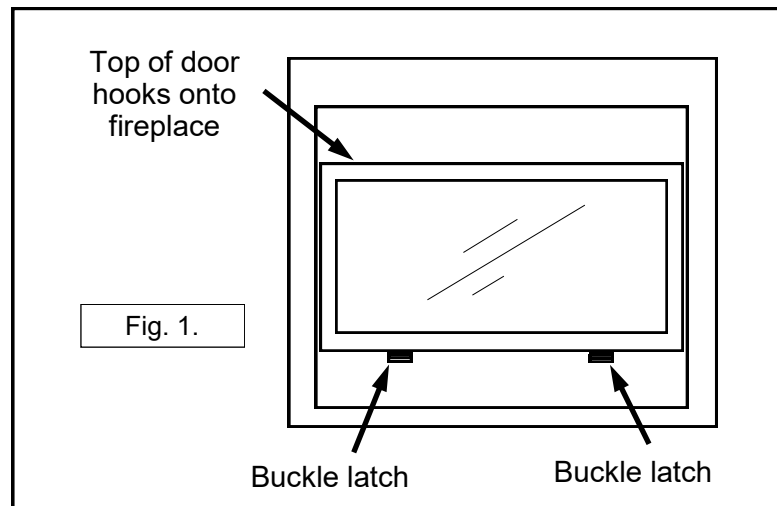

### If Your Glass Breaks

In the event your glass cracks or breaks, replace the original door assembly with an Ambiance replacement door assembly (part number 813-0075). The glass door and frame assembly must be replaced as a complete unit. Remove the barrier screen and remove door as per the instructions above. Replace with new door assembly and reinstall the barrier screen.

**NOTE:** the NEW door will emit some odor when the appliance is lit. The odor will dissipate after the gasket material within the door has cured. Be sure there are no fingerprints left on the glass panels as high temperatures can bake these prints on permanently.

**Warning:** Only doors certified with the appliance shall be used. Do not use substitute glazing materials.

## Barrier Screen Installation and Removal

If barrier becomes damaged, the barrier shall be replaced with the manufacturer's barrier for this appliance (Part Number: 72-BS)

- REMOVE TOP AND BOTTOM LOUVERS (OR OPTIONAL FRONT)
- UNHOOK BOTTOM DOOR LATCHES
- PLACE SAFETY BARRIER OVER DOOR FRAME.

- CONFIRM SAFETY BARRIER TABS ARE SEATED ON TOP OF THE DOOR FRAME.

- PUSH IN BOTTOM OF SCREEN AND DOOR.
- RELATCH BOTTOM DOOR LATCHES

Safety Barrier installed.

- To remove screen, reverse installation process.

### **WARNING**

**DOOR MUST BE INSTALLED PRIOR TO SCREEN INSTALLATION TO AVOID POSSIBLE DAMAGE OR INJURY.**



## LOUVER (UPPER & LOWER GRILLS) INSTALLATION

The 72-DVT30N-2 is packaged without the upper and lower louvers (grills). They must be ordered separately. This is to allow you the option of black, black/gold, black/pewter louvers or all gold louvers.

After opening the louver package, inspect the upper and lower louvers to ensure that no damage has occurred inside the package. Please report any damage immediately to your Authorized Dealer.

Upper Louver installation.

1. Locate the Upper Louver. (Fig. 1)
2. Ensure the glass door is on the appliance.
3. Place the louver in the two catches located at the side of the appliance.

Lower Louver installation.

1. Locate the Lower Louver. (Fig. 1)
2. Locate the Hinges on the Lower Louver. (Fig. 2)
3. Locate the pre-drilled holes on the appliance. (Fig. 3)
4. Line up the hinges (on the louvers) and on the appliance and fasten the louvers with the 4 screws provide in the louver package. (Fig. 4)

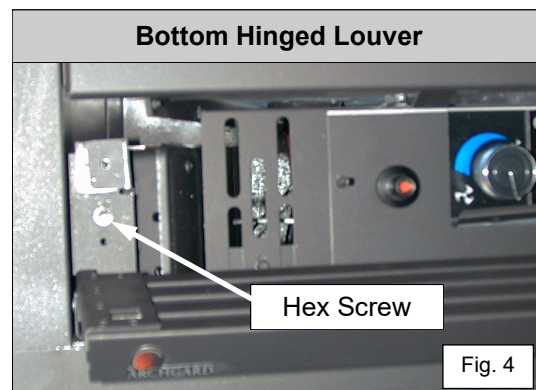
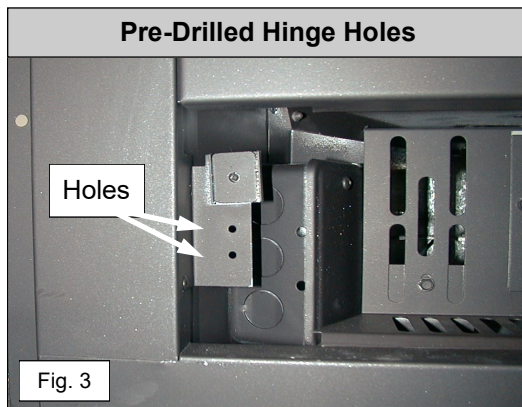
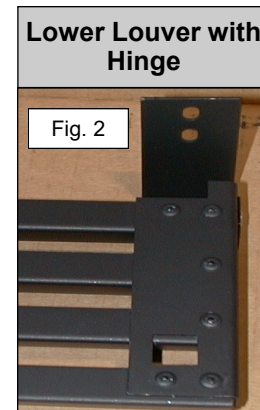
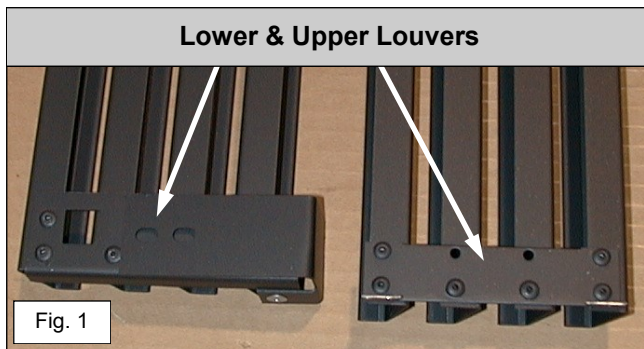

### CAUTION:

Only Trim kit (s) supplied by the manufacturer may be used in the installation of this appliance.

## ECLIPSE FRONT INSTALLATION & REMOVAL

The following steps show how to install the Eclipse front.

The mounting plate for the Eclipse front is installed at the factory using two tek screws on the top and two on the bottom.

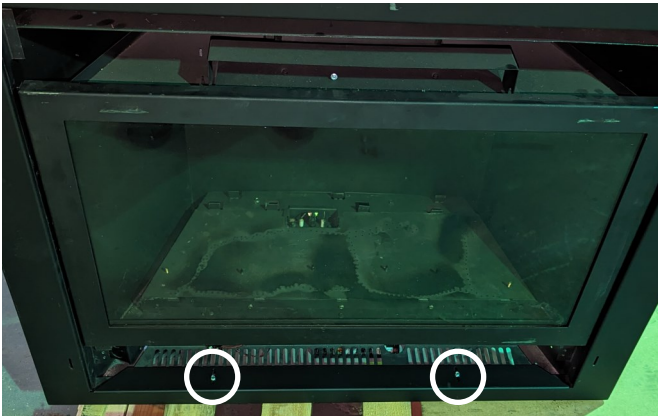

The upper and lower louvers are packed with the fireplace. The upper louver hooks over tabs located above the door. The lower louver hooks over the magnet bracket under the door.

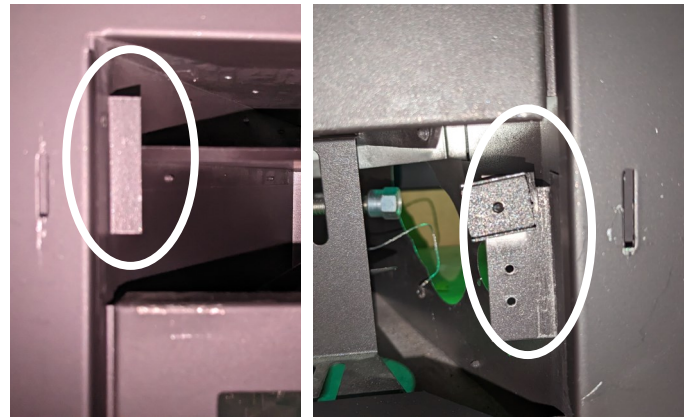
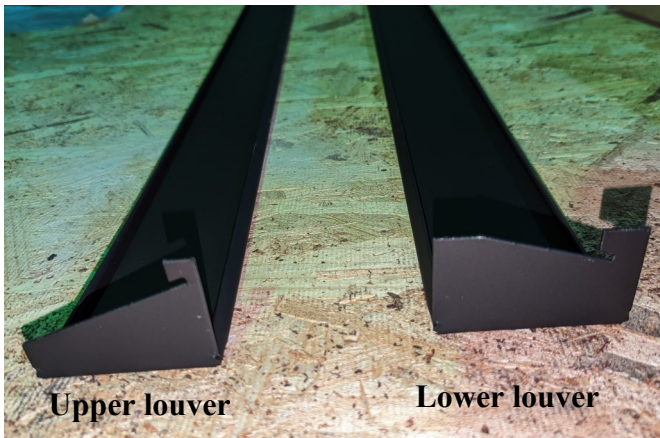

Install the upper and lower louvers.



The front door hooks onto the mounting plate using hooks on each corner.



Hook the front door onto the mounting plate.

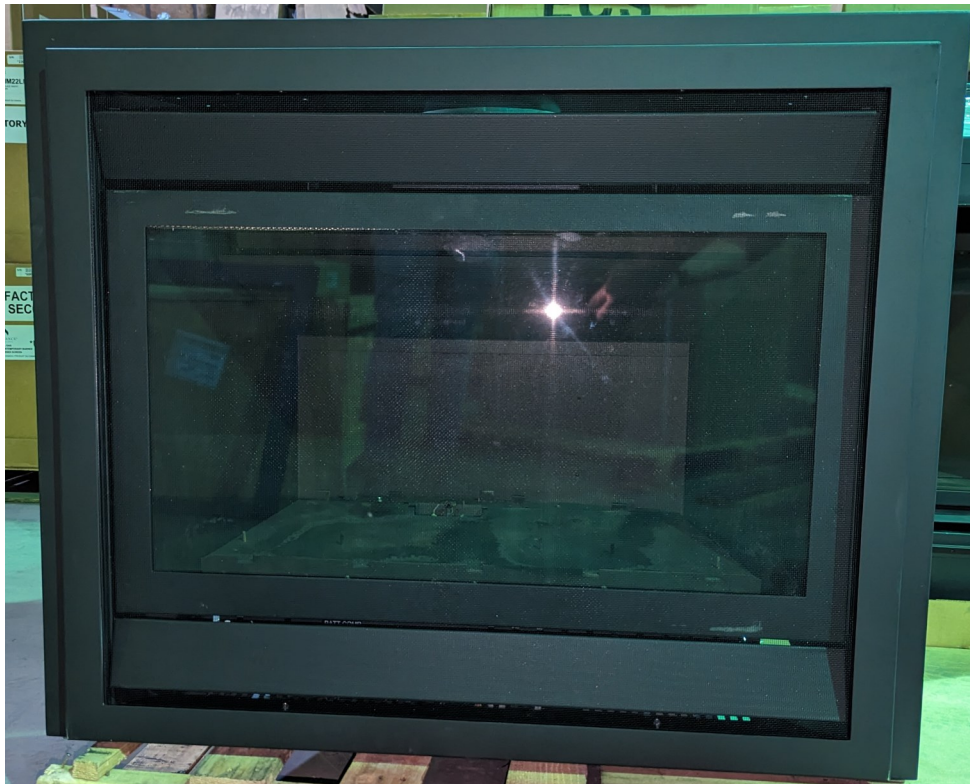

Removal is the reverse of installation.

## ECLIPSE FRONT FIT AND FINISHING

The Eclipse front is adjustable up to 7/8" from the face of the fireplace. This will allow you to install non-combustible finish material behind the front for a cleaner finish.

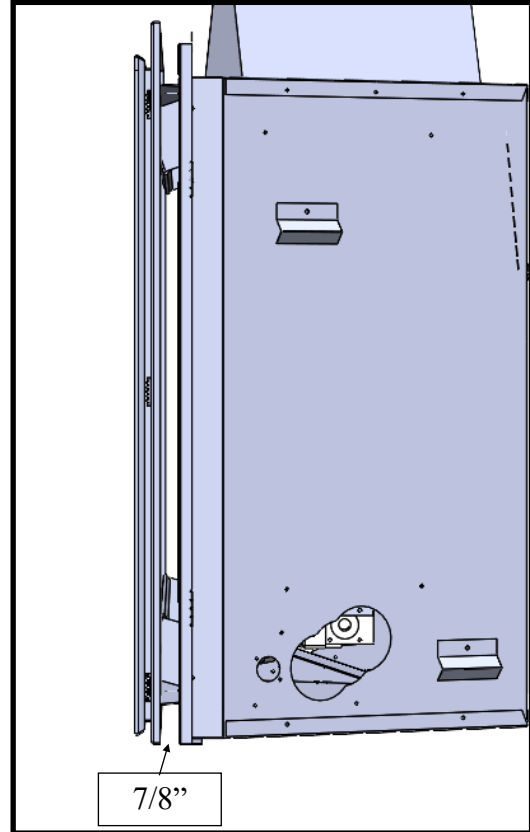
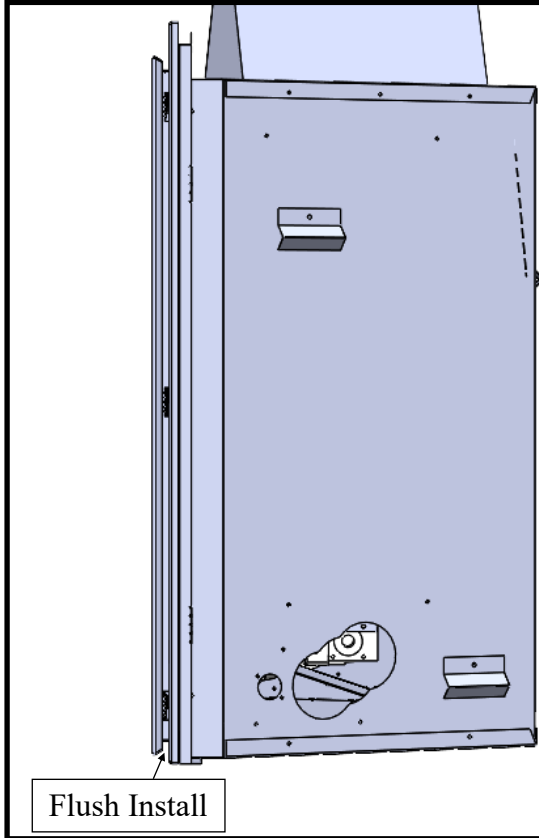

The bottom of the Eclipse has a 1/2" clearance from the bottom of the fireplace.

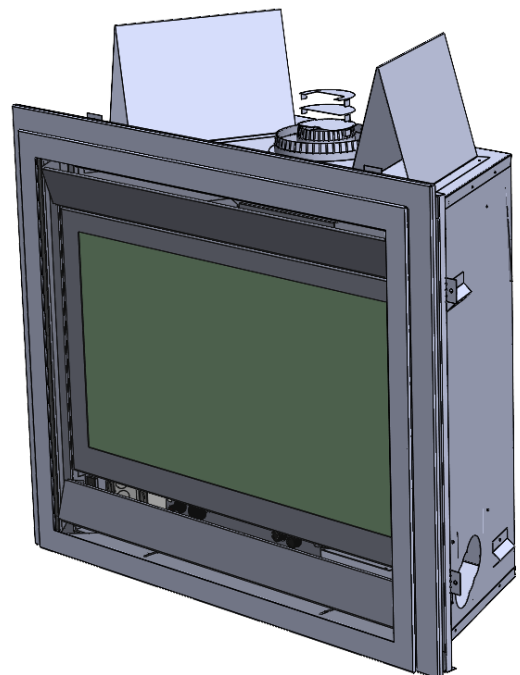
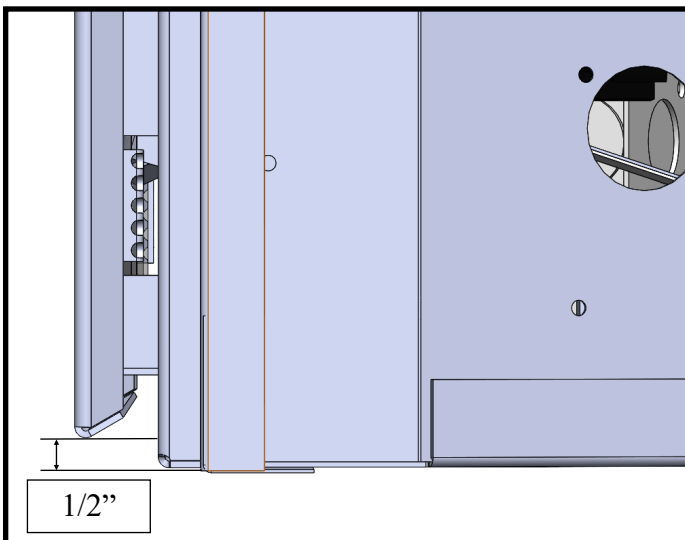

## TROUBLESHOOTING

Please check to make sure the instructions are followed exactly before attempting troubleshooting of the appliance.

**WARNING:** Troubleshooting and servicing of gas and electrical devices of the appliance should only be conducted by a qualified service technician.

SYMPTOM	ACTION
Pilot will not light after pressing the sparker many times.	<ol style="list-style-type: none"> <li>1. When lighting the appliance for the first time after installation or after servicing, there is air in the gas line. It takes a while for all the air to purge out of the pilot before gas can reach the pilot and ignite. Remove the glass door and try lighting the pilot many times to purge the air.</li> <li>2. Check to make sure the gas supply to the appliance is turned on and there is adequate gas supply pressure to the appliance.</li> <li>3. Check for sparks between the spark electrode and the pilot head when the sparker is pressed. If there are no sparks,               <ol style="list-style-type: none"> <li>a. Check for broken or poor connection from the sparker to the electrode.</li> <li>b. Check for the spark shorting or arcing at other locations.</li> <li>c. Check for defective sparker.</li> <li>d. Check for defective spark electrode.</li> </ol> </li> <li>4. With the door removed, try lighting the pilot with a match.               <ol style="list-style-type: none"> <li>a. If air is blowing on the flame of the match, hold the control knob in at the <b>'PILOT'</b> setting until all the air is purged out of the line.</li> <li>b. If there is no gas or air coming out of the pilot and there is gas pressure to the appliance, the pilot orifice may be blocked or the gas valve may be defective.</li> </ol> </li> </ol>
Pilot will not remain on after being lit.	<ol style="list-style-type: none"> <li>1. Press the control knob all the way in (at the "pilot" indicator).</li> <li>2. Hold the control knob in for a longer period of time.</li> <li>3. If you are trying to re-light the pilot immediately after you have shut-off the pilot, you have to wait 5 minutes for the valve to reset. (safety system built into the valve)</li> <li>4. Check to see if the pilot flame is large enough to reach and surround the thermocouple. If the flame is too small, check for correct gas supply pressure. If pressure is good, adjust the pilot flame size with the adjustment screw on the valve. If the flame cannot be adjusted, there might be some debris obstructing the pilot orifice, or a wrong size pilot orifice.</li> <li>5. Check for poor connection of the thermocouple to the valve.</li> <li>6. Check for proper millivolts of the thermocouple. The thermocouple should generate at least 30 mV or it is defective.</li> <li>7. Check for defective gas valve.</li> </ol>
The pilot was lit but will randomly go out.	<ol style="list-style-type: none"> <li>1. Turn the fireplace on again. If the fireplace includes continuous pilot on demand ignition, the system will turn off the pilot if the fireplace has not been used for seven days.</li> <li>2. If the fireplace includes continuous pilot on demand ignition, the pilot wires connected to the valve may be reversed. See Page 30.</li> <li>2. Have a service technician check for low inlet pressure.</li> </ol>
The main burner does not turn on with the pilot lit.	<ol style="list-style-type: none"> <li>1. Check to make sure the control knob is turned to the <b>'ON'</b> position.</li> <li>2. Allow enough time for the pilot to heat up the thermopile to generate sufficient voltage to activate the valve.</li> </ol>

## TROUBLESHOOTING Cont...

SYMPTOM	ACTION
The main burner does not turn on with the pilot lit. Cont...	<ol style="list-style-type: none"> <li>3. Check to make sure the thermostat is set high enough to turn on the appliance.</li> <li>4. Check that the remote switch or the thermostat is turned on.</li> <li>5. Check for weak pilot flame. If the flame is weak, check gas supply, check pilot flame adjustment and check for blockage of pilot orifice.</li> <li>6. Check all connections to the valve for tight electrical contact.</li> <li>7. Check for 400-500 mV from the thermopile with the burner off and 200-250 mV with the burner on. If the voltages are lower, the thermopile is defective.</li> <li>8. Check for defective gas valve.</li> </ol>
The main burner shuts off when the appliance is warm.	<ol style="list-style-type: none"> <li>1. This may be the normal operation of a wall thermostat installed to appliances.</li> <li>2. Check for good pilot flames on the thermopile.</li> <li>3. Check for good voltage from the thermopile.</li> <li>4. Check for proper functioning of venting system (blocked?).</li> <li>5. Check wire connections. Expansion from heat affects a loose connection.</li> </ol>
Sooty deposits on the glass door.	<ol style="list-style-type: none"> <li>1. If the flame is yellow and lazy, check for lint etc. around primary air shutter. Increase primary air by opening the primary air shutter if necessary.</li> <li>2. Check for proper placement of the logs and branches. Ensure logs and burner are clean. See that section in the instruction manual.</li> <li>3. Check for proper venting and blockage of the vent termination.</li> <li>4. Check manifold pressure and clock input rating for over-firing.</li> </ol>
Sharp blue flames with flames lifting off the burner at the ends.	<ol style="list-style-type: none"> <li>1. Too much primary air. Reduce primary air by closing the primary air shutter. During cold temperatures, some flame lifting may occur during start-up.</li> </ol>
Convection blower does not turn on.	<ol style="list-style-type: none"> <li>1. The convection fan is thermostatically controlled. It will only turn on when the appliance is warmed-up. This may take up to 15 minutes with the appliance on high.</li> <li>2. Check for 120 VAC electrical supply to the appliance.</li> <li>3. Check for proper mounting of the thermal snap disc.</li> <li>4. Check electrical connections.</li> <li>5. Check for defective thermal snap disc.</li> <li>6. Check for defective convection blower speed controller.</li> <li>7. Check for defective convection blower.</li> </ol>

## MAINTENANCE

**CAUTION:**

Do not conduct maintenance on the appliance while it is operating or while it is still hot. Always verify proper operation after servicing.

### Cleaning and Routine Maintenance

The exterior painted surfaces, glass, and metal plated trims may be cleaned with a soft, non-abrasive cloth and water or a suitable, mild, non-abrasive cleaner. Be sure there are no fingerprints left on the glass panels as high temperatures can bake these prints on permanently.

**Regularly:**

- Frequent cleaning of the ceramic glass is recommended. We recommend using a good quality ammonia free gas fireplace glass cleaner that is available at any hearth retail location. Take care to avoid scratching glass while cleaning. **DO NOT CLEAN WHILE HOT**. Never use common household cleaners to clean the glass.
- Keep the appliance area free from combustible materials, such as paper, wood, clothing, gasoline and flammable solids, liquids and vapors
- Visually check the height and color of the burner and pilot flames
- Touch up the paint if necessary using a high temperature metallic black paint. Allow the paint to dry prior to lighting the fireplace.

**Once a year, have a qualified service technician:**

- Perform the regular services listed above
- Inspect and operate the pressure relief mechanism (door buckles) to verify they are free from obstruction and operate properly
- Carefully remove the logs and gently brush off any loose carbon deposits. This job is best done outside the house, wearing a dust mask. The logs are very fragile, take care not to break them. Do not wash logs with any liquid. While the logs are removed, check that all burner openings are not obstructed and it is recommended you use a vacuum cleaner to clean off any dust or lint
- Vacuum and clean any lint accumulations or debris in the firebox, on the burners, on the pilot, at the primary air opening, on the convection air blower and in any combustion and convection air passageways
- After cleaning, the logs and embers must be replaced according to the instructions in this manual
- Inspect the operation of the flame safety system pilot and gas valve
- Inspect and ensure the lighting of the main burner occurs within 4 seconds of the main gas valve opening. Flames should match those shown in **Page 45**
- Completely inspect the appliance and the venting system, if the vent pipe or seal is found to be defective, replace and or reseal (follow the instructions found in the venting instructions in this manual)
- Inspect the condition of the vent and vent terminal for sooting or obstruction and correct if present
- Test and measure the flame failure response time of the flame safety system. It must de-energize the safety shutoff in no more than 30 seconds
- Check all accessible gas-carrying tubes, connections, pipes and other components for leaks

**WARNING:**

All parts removed or disturbed, including guards and grills, must be properly replaced after maintenance. Service and repair must be conducted by a qualified service person. If these instructions are not followed, a fire or explosion may result, causing property damage, personal injury or loss of life.

## SERVICING UNDER WARRANTY

Before servicing, read the terms and conditions of the Archgard warranty at the back of the manual. Contact the Authorized Archgard dealer where you purchased the appliance from and provide them with details of the problem together with the initial installation information (from the back of this manual).

**WARNING:** Servicing of this appliance **must be conducted by a qualified Archgard service technician**. Improper servicing, adjustment or alteration of this appliance may cause property damage, personal injury or loss of life. All servicing should be conducted with the appliance cold. All replacement parts must be authorized by Archgard for suitability.

## ADJUSTING PRIMARY AIR

**Caution:** Wear gloves when adjusting the primary air with the appliance hot.

Note: the Shutter is set at the factory and normally only requires resetting at higher altitudes.

1. Open the lower louver.
2. Unscrew the 2 screws holding the control panel and remove the panel. (Fig. 1)
3. The primary air adjustment wing nut is located behind and to the left of the control valve.
4. Loosen the wing nut and slide the primary air shutter to the right to increase primary air and to left to reduce primary air.
5. Tighten the wing nut after adjustment.

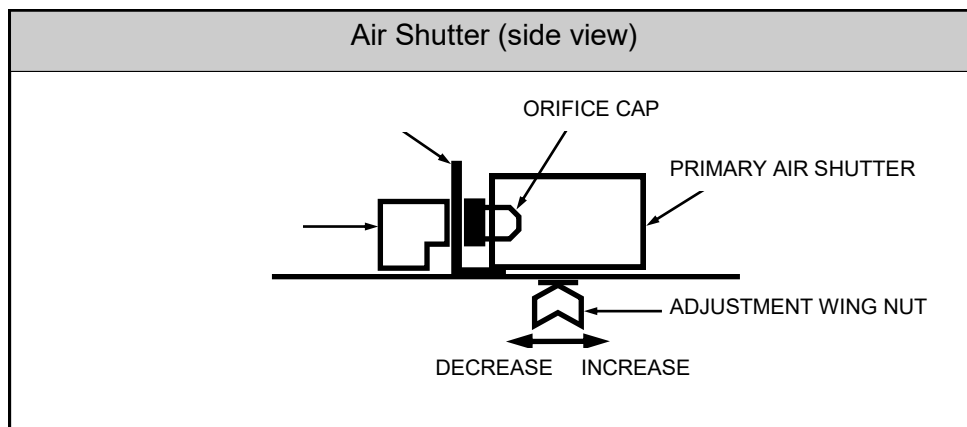

## ADJUSTING PRIMARY AIR

NOTE: (Fig.1) is to give an example of a correct and incorrect flame pattern. It is not a true representation of what the 72-DVT30N-2 will look like in your home environment.

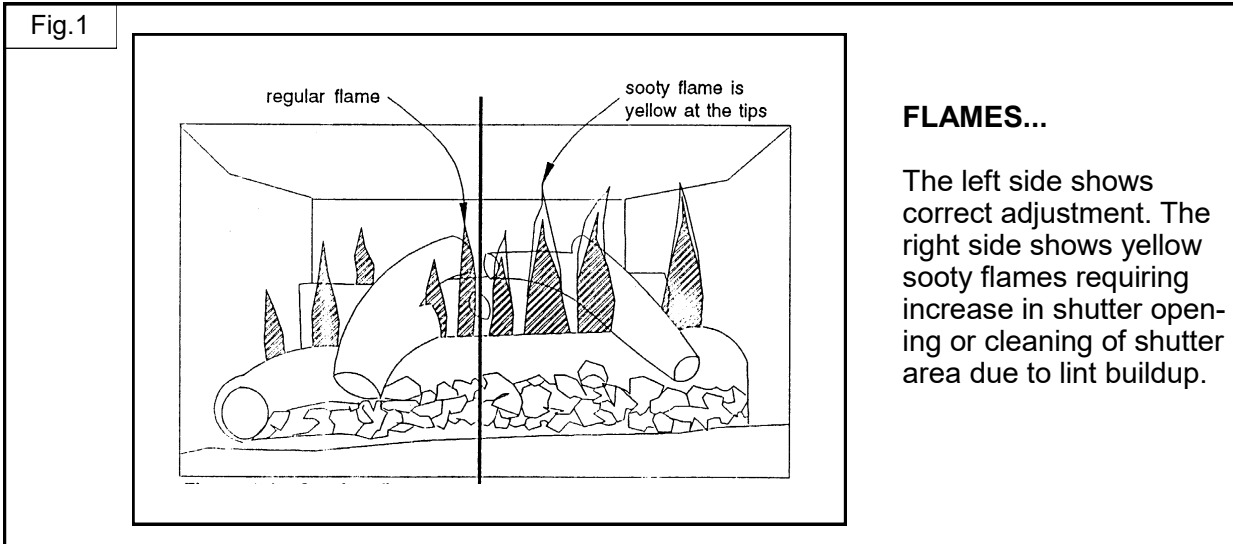

## CHANGING MAIN BURNER ORIFICE

1. Remove the glass door. Follow GLASS DOOR REMOVAL instructions within this manual.
2. Remove the wing nut and washer from the Primary Air Sleeve
3. Locate & slide the Primary Air Sleeve fully toward the left. This will allow the sleeve to disconnect from the burner tube. Follow ADJUSTING PRIMARY AIR instructions within this manual for reassembly.
4. Remove the grate and front logs from the pan burner. See LOG PLACEMENT for instructions.
5. Unscrew the two mounting screws that are located at the back rear of the pan burner.
6. Carefully remove the burner with Air Sleeve by lifting it out.
7. Use a 1/2" (13 mm) wrench to remove the orifice cap.
8. Change the orifice cap to the fuel type desired. Use a small quantity of gas thread seal compound. Do not over tighten.
9. Reverse steps 6 to 1.

THIS APPLIANCE IS EQUIPPED FOR NATURAL GAS. An additional CONVERSION kit is required to convert for Propane use. To order the CONVERSION kit, please contact your Authorized Archgard Dealer.

## CHECKING INLET AND OUTLET GAS PRESSURE

1. Open the lower grills (louvers).
2. The pressure test taps are located on the valve. The taps are located in the gas valve front face. The inlet is marked 'IN' and the outlet is marked 'OUT'. See Fig.1.
3. Loosen the set screw inside the tap with a 1/8" (3 mm) wide flat screw driver.
4. Connect a 1/4" (6 mm) rubber tube to the tap post and a manometer.
5. Verify the readings obtained are within specs (as shown on the appliance rating plate)
6. Be sure to tighten the set screw inside the tap after you are finish taking pressure readings.
7. Check for leaks.

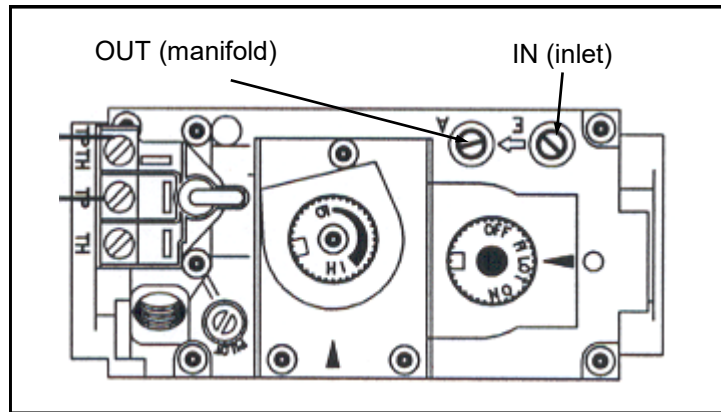
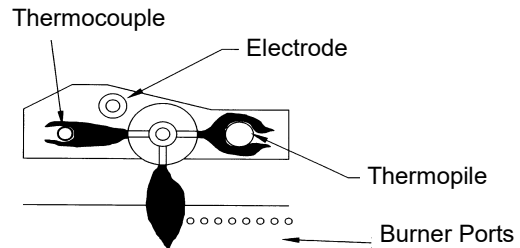

Fig. 1

## CHECKING AND ADJUSTING PILOT

The pilot flame should have the characteristic as shown in the illustration to the right. The flame should not have yellow tips but should engulf the thermocouple and thermopile. It can be adjusted by turning the screw marked "pilot" on the control valve.



## CONVERTIBLE PILOT ORIFICE

The pilot assembly is convertible to the type of gas being used, simply unscrew the body by using a 7/16" (11 mm) wrench turn 1/4 open then push the small metal tab across to the other side of the body and retighten. **Call your local Authorized Archgard Dealer to purchase the correct fuel conversion kit for your gas appliance.**

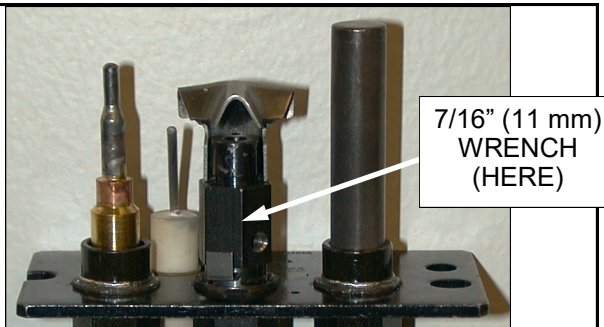

### PILOT POLARITY (SIT 821)

The SIT 821 must be wired with the red thermopile wire connected to the TP TH (+) contact and the white thermopile wire connected to the TP (-) contact.

If these are reversed, the pilot will not stay lit.

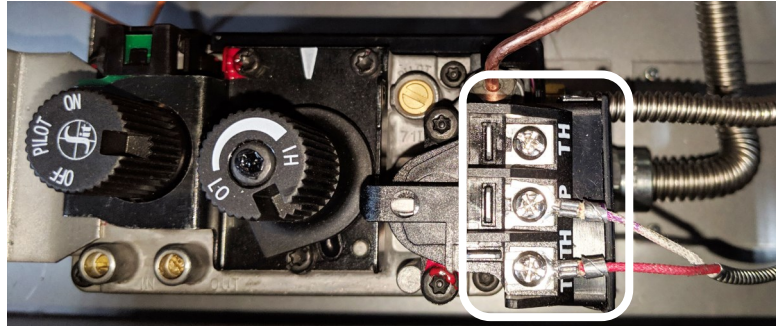

### REPLACING CONVECTION BLOWER

**Caution:** Label all wires prior to disconnection when servicing controls. Wiring errors can cause improper and dangerous operation. Verify proper operation after servicing. This appliance, when installed, must be electrically grounded in accordance with local codes or, in the absence of local codes, with the **National Electrical Code, ANSI/NFPA 70**.

#### NOTES:

- Ensure that the main power and breaker system is turned OFF before removing the fan.
- Make sure the fireplace has been turned off and is cool to the touch.
- Mark all wires to be removed for proper reassembly.

**CAUTION:** Wiring errors cause improper and dangerous operation.

1. The convection blower is located at the bottom of the appliance at the back. Loosen the 3 screws holding the blower.
2. Lift the blower out and disconnect the wires from the blower.
3. Repeat above steps to install new fan.

Please see Wiring Diagram on page 25 of this manual.

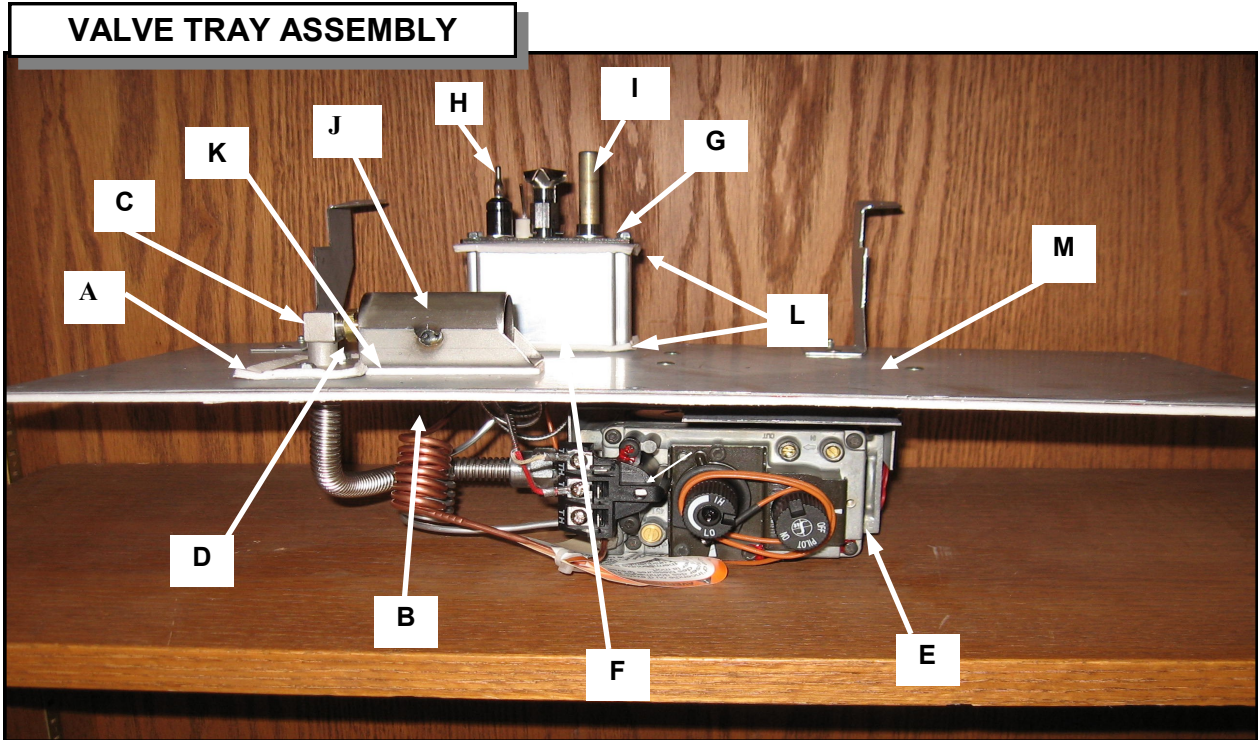

	Item #	Item Description	Qty	Unit
A	314-0015	Flex tub gasket	1	EA
B	308-0120	Wing Nut, Plated Steel (AIR Shutter)	1	EA
C	301-6007	7" Flex line assembly ,flanged orifice	1	EA
D	301-0068-37	Orifice (Main Burner Orifice) Drill to # 37 DMS (2.65 mm) for Natural Gas	1	EA
	301-0068-52	Orifice (Main Burner Orifice) Drill to #52 DMS (1.62 mm) or Propane	1	EA
E	308-0013 Or 308-0018	Valve NOVA SIT 820 (0.820.652) Natural Gas	1	EA
		SIT 821 Natural Gas with 7 Day Pilot on Demand Timer		
F	739-0019	Pilot Assembly Box	1	EA
G	308-0093	Pilot Assembly. Convertible NG/LP Base Mount. Includes the items listed below.....	1	EA
H		Part # 308-6057 - Thermocouple	1	EA
I		Part # 308-0056 - Thermopile	1	EA
J	800-0060	Air Shutter Assembly	1	EA
K	314-0131	Air Shutter Gasket	1	EA
L	314-0127	Pilot Assembly Box Gasket	2	EA
M		Complete Valve Tray Assembly	1	EA

## PARTS LIST - Logs and Pan Burner

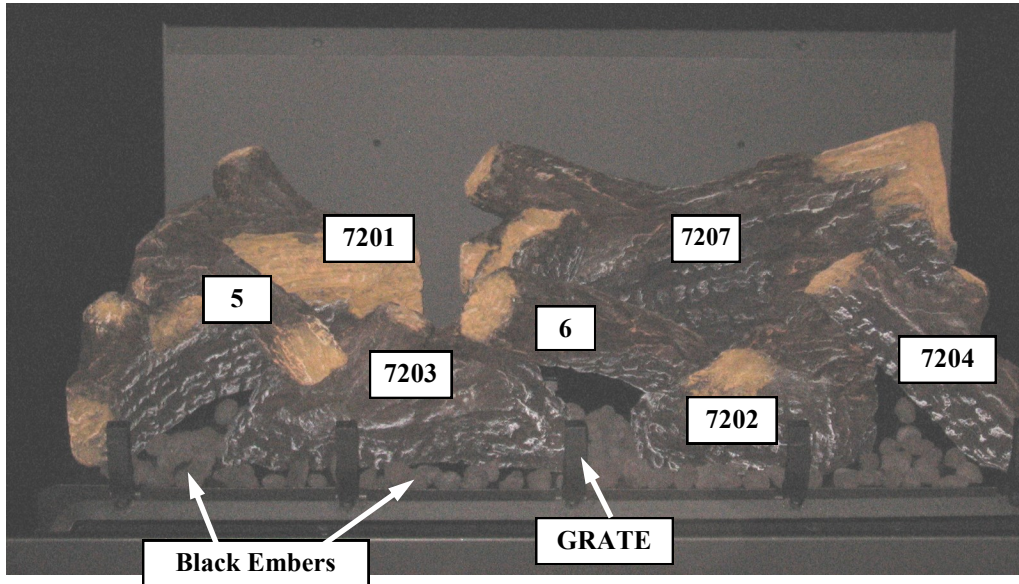

### Pan Burner



Item #	Item Description	Qty	Unit
310-634720-1	Log 7201	1	EA
310-634720-2	Log 7202	1	EA
310-634720-3	Log 7203	1	EA
310-634720-4	Log 7204	1	EA
310-634720-5	Log 7205 (there is only 5 on log)	1	EA
310-634720-6	Log 7206 (there is only 6 on log)	1	EA
310-634720-7	Log 7207	1	EA
872-0060-R2	Grate	1	EA
872-0053	Pan Burner	1	EA
310-0020	Black Embers (2 cup bag)	1	EA

<b>REPLACEMENT PARTS LIST ARCHGARD 72-DVT30N-2</b>
----------------------------------------------------

Item #	Item Description	Qty	Unit
200-1907-11	Owner's Manual	1	EA
300-0031	Magnet Pull (holds bottom louver)	2	EA
300-0034	Catch, Door Latch. (Buckle for door)	2	EA
308-0005	Piezo Igniter Only	1	EA
700-0140	Vent Restrictor #1	1	EA
700-0141	Vent Restrictor #2	1	EA
700-0142-REVA	Vent Restrictor #3	1	EA
308-0046	Knob Extension - ON/OFF 1-1/2" (62 mm)	1	EA
308-0047	Knob Extension - HI/LOW 1-1/2" (62 mm)	1	EA
Fan Components			
305-0013	Fan - Speed Control (Rheostat)	1	EA
305-0017	Fan - Junction Box Cover Plate	1	EA
305-0018	Fan - Junction Box	1	EA
305-0021	Fan - Thermodisc (fan sensor) 110 <sup>o</sup> F. (43 <sup>o</sup> Celsius)	1	EA
RF-305-0024	Fan - Fan with motor and blades. 120VAC, 115V, 24watt (QLN65-0018)	1	EA
702-0047	Fan - Thermodisc mounting bracket	1	EA
702-0050	Fan - Fan Heat Shield	1	EA
Flat Glass Door			
813-0075	Complete Replacement Door. Includes, glass, gasket and door frame (Black Square Door Assembly)	1	EA
813-0076	Complete Replacement Door. Includes, glass, gasket and door frame (Black Arch Door Assembly)	1	EA
72-BS	Barrier Screen	1	EA
Replacement parts for BBAY-70 Bay Door			
300-0031	Magnet Pull	2	EA
307-0030	Glass, 6mm Tempered (Middle Piece)	1	EA
307-0031	Glass, 6mm Temp (Side Piece)	2	EA
308-0048	Knob Ext. ON/OFF 2-1/2" (63 mm)	1	EA
308-0049	Knob Ext. HI/LOW 2-1/2" (63 mm)	1	EA
314-0006	Flat Gasket	72	IN

**REPLACEMENT PARTS LIST ARCHGARD 72-DVT30N-2 (continued)**

<b>Item #</b>	<b>Brick Panel Kit ( Quebec City Red)</b>	<b>Qty</b>	<b>Unit</b>
72-BRPL-QCR	Ceramic Brick Panel Set	1	ST
702-0044	Brick Panel Clips	2	EA
	<b>Brick Panel Kit ( Quebec City Grey)</b>		
72-BRPL-QCG	Complete Brick Panel Set	1	EA
	<b>Brick Panel Kit (Reflective Glass)</b>		
72-BRPL-RG	Complete Reflective Glass Panel Set	1	EA
702-0045	Glass Panel Clips	2	EA

# ARCHGARD LIMITED WARRANTY

This Limited Warranty is made by ARCHGARD INDUSTRIES LTD., hereinafter referred to as “Archgard”. Archgard warrants to the original purchaser of an Archgard gas burning fireplace(s) that the product will be free from defects in materials and workmanship under normal use and service, for a “lifetime”. All warranty repairs are to be performed by an authorized Archgard Dealer during the warranty period. Other repair / service company charges for any work done during the warranty period, will be the responsibility of the home owner.

## **INCLUSIONS: “LIFETIME LIMITED WARRANTY”**

All heat exchangers and combustion chamber  
Ceramic Fiber Logs and Ceramic Brick Panels, against splitting and cracking due to heat exposure

**NOTE:** Discoloration and some minor movement including warping of certain parts are normal and are not a defect; therefore, not covered under warranty.

## **INCLUSIONS: “SEVEN YEAR LIMITED WARRANTY”**

Burner tubes and pans

## **INCLUSIONS: “TWO YEAR LIMITED WARRANTY”**

Ceramic Glass against thermal breakage  
Trims and accessories from splitting or separating  
Electronic Control Module, Remote Transmitter

Items included with ten-year and two-year limited warranty will be covered under “Parts & Subsidized Labour” to the original purchaser for one (1) year and “Parts Only” thereafter from original date of purchase.

## **INCLUSIONS: “ONE YEAR LIMITED WARRANTY”**

Blowers, fans and fan motors, wiring, rheostats and thermoswitches  
Rocker switches, spill switches and wiring to them  
Gas control valves, pilot assemblies including thermopiles, thermocouples, electrodes and igniters  
Paint peeling or cracking

Items included in the one-year limited warranty will be covered under “Parts & Subsidized Labour” to the original purchaser for one (1) year from date of purchase.

## **WHAT TO DO IN THE EVENT OF A PROBLEM:**

Thoroughly read your “Owner’s Installation, Operation & Maintenance Manual”

If you cannot solve the problem, contact your Archgard dealer or representative

When calling for assistance, please have the following information:

**Model of your fireplace    Serial Number**

**Place of Purchase**

**Date of Purchase**

**Problem Description**

**NOTE:** Warranty will be void if work is carried out by an unqualified person(s). Only original Archgard parts may be used. Please consult your Archgard dealer or representative if in doubt about a replacement part(s).

All warranty repairs are to be performed by an authorized Archgard Dealer during the warranty period. Other repair / service company charges for any work done during the warranty period, will be the responsibility of the home owner.

## **OBTAINING WARRANTY SERVICE:**

The original purchaser shall return the defective part(s) to the original authorized Archgard dealer – transaction prepaid, along with the serial number of the appliance and original proof of purchase. Any defective part, in our judgment, will be repaired or replaced at Archgard’s discretion. The dealer must obtain approval from Archgard before any repairs are made.

## **WARRANTY LIMITATION:**

THIS LIMITED WARRANTY IS MADE IN LIEU OF ALL OTHER WARRANTIES, EXPRESSED OR IMPLIED AS TO QUALITY, MERCHANTABILITY OR FITNESS FOR PARTICULAR PURPOSE.

The appliance is only warranted for the use as intended by the installation and operating instructions and local building codes. The warranty will not cover damage due to accident, misuse, abuse, alteration, improper installation or “Acts of God”. This limited warranty is void unless the appliance is installed by a qualified Archgard installer, in accordance with the instructions furnished with the appliance. Some Provinces or States do not allow limitations on how long an implied warranty lasts, so the above limitations may not apply to the original purchaser. Any damage resulting from defects in this product is limited to the replacement of the defective part(s) and does not include incidental and consequential exposures sustained in connection with the product. This includes facing(s), mantle(s), cabinet(s), tile(s) or any other finishes resulting from removal of any gas appliance. This warranty is limited to residential use only and gives the consumer specific rights. These rights may vary from State to State or Province to Province.

## **WARRANTY CONDITIONS & REQUIREMENTS:**

1. You are the original purchaser – this warranty is not transferable.
2. Installation of the fireplace must be performed by a qualified Archgard installer.
3. Installation and operation must comply with the installation and operation instructions.
4. All optional accessories are covered for one (1) year from the date of purchase.
5. This warranty does not offer coverage for light bulbs or batteries (whether factory, dealer, or installer supplied). This includes any damage stemming from non-use.
6. Damage during shipping or handling of components, defects resulting from improper installation or service, or misuse of the fireplace or fireplace components are not covered under this warranty.
7. This warranty does not cover any part of the fireplace or any component which has been exposed to or submerged under water.
8. Archgard must be notified by the dealer the fireplace was purchased from or a qualified Archgard technician of the defect.
9. Annual service of the fireplace as required in the installation manual must be performed by a qualified Archgard technician (service records may be required to claim a warranty).
10. All previous warranty service must have been performed by a qualified Archgard technician (service records may be required to claim a warranty).
11. Travel time or mileage to the original purchaser’s residences is not covered under this warranty. We suggest that you pre-arrange travel expenses with your Authorized Archgard Dealer.
12. Freight on warranty shall be covered for the first two years of the warranty period.

# 72-DVT30N-2

## Frequently Asked Questions

Listed below are some frequently asked questions about your Archgard Gas Fireplace. If you have questions that are not listed below, or are not answered in this manual, please contact your Authorized Archgard Dealer.

Q. My glass has a condensation “fog” when the appliance is first lit.

A. Condensation is normal and will disappear in a few minutes after the glass is heated.

Q. I have a white “film” on my glass. What is the best way to clean the inside of the glass?

A. Frequent cleaning of your glass is recommended. Archgard recommends using a good quality “gas fireplace” glass cleaner that is available at all authorized dealers. Do not use abrasive materials, and do not clean the glass or the appliance when the unit is hot.

Q. How do I care for my gold plated trims?

A. Archgard recommends a cleaning with a damp cloth. DO NOT use chemical cleaners as they may harm the finish, and void your warranty. NOTE: If the top louvers, or top overlay starts to discolor, check the door gasket seal and replace if necessary.

Q. My fan/blower makes a “whirring” or “humming” noise.

A. Your Archgard gas appliance uses a powerful fan to push heated air into your room. It is not unusual to hear a “humming” noise when your fan is running. Note: the sound will change depending on the setting that your fan speed control is set at.

Q. I hear a “click” when my fan system activates.

A. When your appliance reaches temperature, it will activate the THERMODISC “fan switch”. The switch closes the electrical circuit that allows the fan to turn on. This is a normal sound.

Q. I hear a “ticking”, “cracking” or “pinging” sound when my fireplace is running, and after it is turned off.

A. The different gauges of steel used to manufacture your fireplace will expand and contract at different rates when your fireplace is on, and will continued as your fireplace completes its heating function. You will likely hear these same sounds more on start up and shut down. This is normal for steel fireplaces.

Q. When my appliance is OFF and my pilot light is lit, I hear a “whisper” sound.

A. The lit pilot can make a small noise. Sometimes in extreme wind conditions you may be able to hear air entering into the firebox chamber.

Q. I hear a “click” when my main burner turns ON or OFF.

A. Your Gas Control Valve will make a clicking sound when it opens to allow gas to flow to the main burner. This is a normal part of the operating system.

Q. Can I burn wood and other materials in my gas fireplace.

A. No! Burning anything other than natural or LP gas in a gas fireplace or stove will create a potential fire hazard and present a danger to your home and its occupants. Only burn the gas fuel for which the unit was originally designed.

Q. Can I shut my pilot off in the summer?

A. You will save energy by turning off the pilot light if you are not using your appliance for the hot summer months. Remember to relight it before you want to use the appliance for the first time in the fall. Refer to your owners manual for lighting instructions. If your fireplace comes equipped with Pilot on Demand Ignition (CPOD), the pilot will automatically extinguish after 7 days without using the fireplace.

Q. Can I position my gas logs in a different fashion or use a different log set?

A. No. Your gas fireplace is an engineered system that includes the firebox, burner, logs, venting and options which are tested and listed by CSA. Changing any specifications or placement of the logs could void your manufacturer's warranty, and possible even your homeowner's warranty.

---

**NOTES**



POSTAGE

# WARRANTY REGISTRATION

**ARCHGARD INDUSTRIES LTD.  
PO BOX 318  
RAYMOND, AB  
TOK 2S0**

FOLD DOWN AT LINE

FOLD DOWN AT LINE & TAPE CLOSED

Model # : 72-DVT30N-2 Serial #: \_\_\_\_\_ Date Installed: \_\_\_\_\_ / \_\_\_\_\_ / \_\_\_\_\_  
mm dd yyyy

Name: \_\_\_\_\_ Address: \_\_\_\_\_

City: \_\_\_\_\_ State/Prov: \_\_\_\_\_ ZIP: \_\_\_\_\_ Phone: ( \_\_\_\_\_ ) \_\_\_\_\_

Dealer's Name & Address: \_\_\_\_\_

City: \_\_\_\_\_ State/Prov: \_\_\_\_\_ ZIP: \_\_\_\_\_ Phone: ( \_\_\_\_\_ ) \_\_\_\_\_

Installer's Name & Address: \_\_\_\_\_

City: \_\_\_\_\_ State/Prov: \_\_\_\_\_ ZIP: \_\_\_\_\_ Phone: ( \_\_\_\_\_ ) \_\_\_\_\_

Why did you choose this product? \_\_\_\_\_

*Thank you for purchasing our product and filling out this warranty card.*

CUT ALONG LINE

CUT ALONG LINE

CUT ALONG LINE

**ARCHGARD INDUSTRIES LTD.**  
300 RAILWAY AVENUE  
RAYMOND, AB TOK 2S0  
CANADA

[WWW.ARCHGARD.COM](http://WWW.ARCHGARD.COM)