



Kōjin 62
MODEL: 62-DVTE46CN-1
GAS FIRED DIRECT VENT FIREPLACE
S/N 530033 AND UP

INSTALLATION, OPERATION, AND MAINTENANCE MANUAL



This appliance may be installed in an aftermarket permanently located, manufactured home (USA only) or mobile home where not prohibited by local codes.

This appliance is only for use with the type of gas indicated on the rating plate. This appliance is not convertible for use with other gases, unless a certified kit is used.



WARNING:

FIRE OR EXPLOSION HAZARD

Failure to follow safety warnings exactly could result in serious injury, death, or property damage.

- Do not store or use gasoline or other flammable vapors or liquids in the vicinity of this or any other appliance.

- WHAT TO DO IF YOU SMELL GAS:

- Do not try to light any appliance
- Do not touch any electrical switch; do not use any phone in your building
- Leave the building immediately
- Immediately call your gas supplier from a neighbor's phone. Follow the gas suppliers instructions
- If you can not reach your gas supplier, call the fire department

- Installation and service must be performed by a qualified installer, service agency or the gas supplier.

English and French Installation Manuals available through your local dealer or visit our website at: www.archgard.com
 Les manuels d'installation en anglais et en français son disponibles chez votre détaillant local ou en visitant notre site web: www.archgard.com



DANGER



HOT GLASS WILL CAUSE BURNS.

DO NOT TOUCH GLASS UNTIL COOLED.

NEVER ALLOW CHILDREN TO TOUCH GLASS.

A barrier designed to reduce the risk of burns from the hot viewing glass is provided with this appliance and shall be installed for the protection of children and other at-risk individuals.

NATIONAL FIREPLACE INSTITUTE



CERTIFIED
www.nficertified.org

We recommend that our gas hearth products be installed and serviced by professionals who are certified in the U.S. by the National Fireplace Institute® (NFI) as NFI Gas Specialists.

INSTALLER:

LEAVE THIS MANUAL WITH THE APPLIANCE.

CONSUMER:

RETAIN THIS MANUAL FOR FUTURE REFERENCE.

ARCHGARD FIREPLACE PRODUCTS

300 Railway Avenue
 Raymond, AB T0K 2S0 Canada

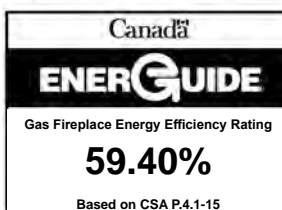

200-0284-03
 April 01, 2026

TABLE OF CONTENTS

1.0 Introduction	3	13.0 Gas Connections	37
2.0 Safety Information	4	13.1 Clocking Procedure.....	37
3.0 Technical Information	5	13.2 Supplying Gas.....	38
3.1 Appliance Certification.....	5	14.0 Conversion Kit Instructions	39
3.2 Installation Codes.....	5	14.1 Prepare the Fireplace.....	39
3.3 Specifications.....	5	14.2 Pilot Conversion.....	40
3.4 High Altitude Installation.....	5	14.3 Convert the Gas Valve.....	41
4.0 Rating Plate	6	14.4 Complete the Conversion.....	41
5.0 Installation Checklist	7	15.0 Firebox Liner Installation	42
6.0 Appliance Overview	8	15.1 Midnight Black Panel Installation.....	42
6.1 Appliance Overview.....	8	15.2 Reflective Glass Installation.....	44
6.2 Rating Plate Location.....	9	15.3 Refractory Panel Installation.....	48
6.3 Barrier Screen (62-BS).....	10	16.0 Burner Media Installation	51
6.4 Glass Door Installation.....	11	17.0 Operation	52
6.5 Accessing The Controls.....	12	17.1 Before Lighting.....	52
7.0 Electrical Connections	13	17.2 First Fire.....	52
8.0 Fireplace Dimensions	14	17.3 Lighting Instructions.....	53
9.0 Prepare The Fireplace	15	17.4 Remote Control Operation.....	54
9.1 Installation Overview.....	15	18.0 Maintenance	60
9.2 Nailing Flange Tabs.....	15	18.1 Cleaning and Routine Maintenance.....	60
9.3 Nailing Flange Extension.....	16	18.2 Servicing Under Warranty.....	61
10.0 Venting Instructions	18	18.3 Checking Inlet and Outlet Pressure.....	61
10.1 Vent Run Guide:.....	20	18.4 Checking and Adjusting Pilot.....	61
10.2 Vent Run Guide: 5" x 8".....	21	18.5 Adjusting the Primary Air.....	62
10.3 Vent Restrictor Configuration.....	22	18.6 Replacing Batteries.....	63
10.4 Third Party Venting Components (4 x 6 ⁵ / ₈).....	23	18.7 Replacing Fuse.....	63
10.5 Third Party Venting Components (5 x 8)	25	18.8 Disabling CPI.....	63
10.6 Termination Location Clearances.....	27	18.9 Replacing Light Bulbs.....	64
10.7 Snorkel Termination Installation.....	29	18.10 Replacing the Control Board.....	65
11.0 Framing	30	18.11 Wiring Schematic.....	66
11.1 Wall Enclosure Rough Opening.....	30	18.12 Removing the Baffle.....	67
11.2 Ventilation Framing, 5" x 8".....	31	18.13 Removing the Burner Surround.....	68
12.0 Clearances to Combustibles	32	18.14 Replacing the Burner.....	70
12.1 Mantel Clearances.....	32	18.15 Replacing the Fans.....	71
12.2 Sidewall Clearances.....	33	18.16 Replacing the Pilot.....	73
12.3 Optional Hearth Installation.....	33	18.17 Replacing the Light Bases.....	74
12.4 Finishing.....	34	18.18 Troubleshooting.....	75
12.5 Installation of Grandview Park Decorative Front.....	36	19.0 Frequently Asked Questions	76
		20.0 Replacement Parts List	77

General Information

1.0 Introduction

Thank you and congratulations for choosing an Archgard gas fireplace!

Kōjin (KOH-JIN)- Kōjin is the Japanese god of fire, the hearth, and the kitchen. He embodies fire, controlled and turned toward a good purpose and is said to destroy all impurity. Archgard's Kōjin 62 molds the flame to provide a contemporary, linear wall-to-wall fire that will fill your space with pure tranquility. With lines unlike any other linear fireplace, the Kōjin will draw every eye in the room.

This unrivaled flame is backed by the latest fireplace technology and designed to be the burning heart of your home. The Kōjin 62 is one of the most advanced Direct Vent heaters available today. It is solidly constructed and manufactured to the highest quality. It is our aim to provide you with an appliance that brings many trouble-free years of reliable service. This manual provides information regarding model number **62-DVTE46CN-1**.

Some of the many features of your **62-DVTE46CN-1** are:

- **Heater Classification** This fireplace is classified as a heating appliance. Therefore, it uses Direct Vent safety technology and it is suitable for continuously operated zone heating.
- **High Efficiency** This fireplace has one of the highest efficiencies of any Direct Vent gas fireplace heaters, ensuring it is less expensive to operate.
- **Adjustable Fan Speed** This fireplace comes complete with two adjustable six speed circulation fans controlled with the remote.
- **Adjustable Flame** This fireplace provides the ability to adjust the flame aesthetics and heat output to suit the owner's liking and heating needs.
- **Adjustable Lighting** Use the included remote to choose from six levels of accent lighting or leave the light off and allow the flame to provide a flickering glow.
- **Solid Construction** This fireplace is mainly constructed of 16 and 18 gauge galvanized and aluminized coated steel for long life and durability.
- **Optional Accessories** Speak with your local authorized Archgard dealer for a full complement of decorative accessories to suit your home's decor and personal tastes.
- **Electronic Control System** This fireplace uses a gas control valve that is operated by a multifunction remote control. It can be used as either an Intermittent Pilot Ignition (IPI) system or Continuous Pilot Ignition (CPI) system.

Model Number Definition (62-DVTE46CN-1)

62	Diagonal dimension of the fireplace opening in inches
DVT	Direct Vent Fireplace, Top Vented
E	Electronic Ignition
46	Natural Gas Input Rating in BTU (46,500)
C	Contemporary
N	Natural Gas (optional propane conversion kit available)
-1	Revision Number

CPI vs IPI:

Continuous Pilot on Demand Ignition (CPI): In this mode the pilot runs continuously even when the main burner is off. The Continuous Pilot on Demand Ignition operates on a seven day cycle. If the main burner is not turned on for seven continuous days, the pilot will turn itself off. When the main burner is lit again the cycle repeats. The pilot will remain lit for seven days, even after the main burner is turned off. If the main burner is lit during a seven day timing cycle, the seven day timer will reset.

Intermittent Pilot Ignition (IPI): A fuel saving mode in which the pilot is only used when the main burner is on.

This appliance is shipped in IPI mode. IPI mode is often the preferred method, however, there are some situations where it may be preferable to switch the fireplace into CPI mode. For example, in colder climates the glass door or the front of the fireplace could become very cold to the touch. Dynamic Start Advantage will solve most problems experienced by older IPI operated fireplaces.

Please complete and submit the warranty registration card included in the back of this manual or by visiting us at:
www.archgard.com/warranty-registration

2.0 Safety Information

Caution

FOR YOUR SAFETY - Do not install or operate your **62-DVTE46CN-1** without reading and understanding this manual. Any installation or operational deviation from this instruction manual voids the warranty and may prove hazardous.

- This appliance must be installed by a qualified gas installer and the installation must conform to the installation codes
- Provide adequate clearance around air openings into combustion chamber
- Never obstruct front openings
- Provide adequate clearances for proper operation and servicing of the appliance
- This appliance must be properly connected to an approved venting system and must not be connected to a chimney flue serving a separate solid fuel burning appliance
- Flow of combustion and ventilation air must not be obstructed
- Always provide adequate clearance around the intake and exhaust openings

Safety

- Due to high temperatures, the appliance should be located out of traffic and away from furniture and draperies
- Children and adults should be alerted to the hazards of high surface temperature and stay away to avoid burns or clothing ignition
- If this appliance is installed directly on carpeting, tile, or other combustible material other than wood flooring, the appliance shall be installed on a metal or wood panel extending the full width and depth of the appliance
- Young children should be carefully supervised when they are in the same room as the appliance. Toddlers, young children and others may be susceptible to accidental contact burns. A physical barrier is recommended if there are at risk individuals in the house. To restrict access to a fireplace or stove, install an adjustable safety gate to keep toddlers, young children and other at risk individuals out of the room and away from hot surfaces
- Do not store or place combustibles, gasoline, and other flammable vapors and liquids near the appliance
- Clothing or other flammable material should not be placed on or near the appliance
- **WARNING:** Do not operate appliance with the glass front removed, cracked, or broken. Removal of the glass should be done by a licensed or qualified service person. Do not to strike or slam the glass
- Any safety screen or guard removed for servicing an appliance must be replaced prior to operating
- Installation and Repair should be done by a qualified service person. The appliance should be inspected before use and at least annually by a professional service person. More frequent cleaning may be required due to excessive lint from carpeting, bedding materials, etc. It is imperative that the control compartments, burners and circulating air passageways of the appliance are kept clean
- Under no circumstances should any solid fuel (wood, coal, paper or cardboard, etc.) be used in this appliance
- Keep burner and control compartment clean
- Do not use this appliance if any part has been under water. Immediately call a qualified service technician to inspect the appliance and to replace any part of the control system and any gas control which has been under water

Each Archgard Gas Fireplace is checked and tested at the factory prior to being packaged and shipped to our dealers and finally installed in your home. Before leaving this unit with the customer, the installer must ensure that the appliance is firing correctly and that the electrical system is in working order. The Installation Checklist in **Section 5.0** should be used to ensure the proper installation of this gas fireplace heater and to document any deviations from a typical install.

Any alteration to the product that causes carbon or soot deposits that results in any damage or requires cleaning is not the responsibility of the manufacturer.

General Information

3.0 Technical Information

3.1 Appliance Certification

This appliance was listed by QAI Laboratories Inc to the following USA and Canadian gas appliance standards.

- ANSI Z21.88-2019/CSA 2.33-2019 Vented Gas Fireplace Heaters
 - CSA-2.17-2017, Gas-Fired Appliances for Use at High Altitudes
 - CSA P.4.1-15 testing method for measuring annual fireplace efficiency.
 - CSA C22.2 No.3 - M1988(R.2014) - Electrical Features of Fuel-Burning Equipment
- The listing label is attached to the appliance on the bottom right side of the appliance.
A copy is shown on **Section 4.0**.

Commonwealth of Massachusetts: This appliance has been manufactured in accordance with Massachusetts code 248 CMR 5.00. Approval Code: TBD. (https://licensing.reg.state.ma.us/pubLic/pl_products/pb_pre_form.asp).

Please contact **Archgard Industries Ltd.**, if you have any questions regarding the certification of this appliance.

3.2 Installation Codes

This appliance must be installed by a qualified gas appliance installer. The installation must conform with the local codes or, in the absence of local codes, with the current National Fuel Gas Code ANSI Z223.1/ NFPA 54 in the US, or Installation Code CAN/CGA-B149.1 in Canada. Electrical connections and grounding must conform with local code, or current National Electrical code ANSI/NFPA No. 70-1987 in the US, and in Canada the current Canadian Electrical Code CSA C22.1.

We recommend that our gas hearth products be installed and serviced by professionals who are certified in the U.S. by the National Fireplace Institute® (NFI) as NFI Gas Specialists.

3.3 Specifications

	Natural Gas (NG)	Propane (LP)
Manifold Pressure	1.1 - 3.8 in. W.C. (0.27 - 0.95 kPa)	2.9 - 11.0 in. W.C. (0.72 - 2.74 kPa)
Min. Supply Pressure Max Supply Pressure	5 - 14 in. W.C. (1.2 - 3.5 kPa)	12 - 14 in. W.C. (2.99 - 3.5 kPa)
Orifice Size	2 x #42 DMS (2.4 mm dia.)	2 x #53 DMS (1.5 mm dia.)
Input Rating	25,000 - 46,500 BTU/hr (7.33 - 13.63 kW)	25,000 - 46,500 BTU/hr (7.33 - 13.63 kW)
P.4 Fireplace Efficiency (FE)	59.40%	
P.4 Steady State Efficiency	67.26%	
Electrical Rating	120 VAC, 60 Hz, less than 2 A.	
Gas Control	SIT 885 Proflame II Dynamic Start Advantage with Continuous Pilot on Demand	
Altitude	0 - 4500 ft (0 - 1372 m)	
Primary Air Opening	Closed	1/4" (6.35 mm) Open

3.4 High Altitude Installation

When installing this appliance beyond 4500 ft. (1372 M) above sea level, the appliance must be properly derated and installed according to local codes, in the absence of local codes, with the current National Fuel Gas Code, ANSI Z223.1/ NFPA 54, in the US or Installation Code, CAN/CGA-B149.1, in Canada.

General Information

4.0 Rating Plate

DO NOT REMOVE THIS LABEL



MODEL: 62-DVTE46CN-1

LISTED VENTED GAS FIREPLACE HEATER and GAS-FIRED APPLIANCES FOR USE AT HIGH ALTITUDES. Tested to: ANSI Z21.88-2019 / CSA 2.33-2019, CSA 2.17-2017, CSA P.4.1-15, and CSA 22.2 No.3-M1988 (R2014). This vented gas fireplace heater is not for use with air filters. Certified for use in both CANADA and USA.

VENTED GAS FIREPLACE HEATER-NOT FOR USE WITH SOLID FUEL.
Manufactured as Natural Gas

	NG	LPG
Input rating	25,000 - 46,500 BTU/hr (7.33 - 13.63 kW)	25,000 - 46,500 BTU/hr (7.33 - 13.63 kW)
Manifold Pressure	1.1 - 3.8 in. W.C. (0.27 - 0.95 kPa)	2.9 - 11.0 in. W.C. (0.72 - 2.74 kPa)
Orifice size	2 x #42 DMS (2.4 mm dia.)	2 x #53 DMS (1.5 mm dia.)
Supply pressure (Min - Max)	5 - 14 in. W.C. (1.2 - 3.5 kPa)	12 - 14 in. W.C. (2.99 - 3.5 kPa)
Burner Primary Air Setting	Closed	1/4" (6.35 mm) Open
Altitude	0 - 4500 ft (0 - 1372 m)	0 - 4500 ft (0 - 1372 m)
Gas Control	SIT 885 Proflame II Dynamic Start with Continuous POD	
Electrical rating	120 VAC, 60 Hz, less than 2 A.	
P.4.1 Fireplace Efficiency (FE)	59.40%	
Replacement fan	Part no. RF-305-0024 fan must be used (qty 2)	
Keep burner and control compartment clean. See Instructions accompanying the heater. Optional fuel conversion kit : See Manual	Minimum clearances to Combustibles: Chase sides, back & top from fireplace standoffs: 0" (0 cm). Interior sidewall from fireplace opening: 3" (7.62 cm). Mantle: 8" (20.32 cm) mantel at min 24" (60.95 cm) from top of the fireplace opening. Vent pipe: Sides & Bottom: 1" (2.54 cm), Top: 2" (5.08 mm). Ceiling: 60" (152.4 cm) from fireplace opening. See Manual for additional dimensions and clearances. See IHEAT Manual for clearances with IHEAT installed.	

This appliance must be installed in accordance with local codes, if any; if none, follow the National Fuel Gas Code, ANSI Z223.1/NFPA 54, or Natural Gas and Propane Installation Codes, CSA B149.1. Electrical connections and grounding must be in accordance with local codes, if any; if none, follow the current CAN/CSA C22.1 in Canada and ANSI/NFPA 70 in the US. This appliance is certified for installation in a bedroom or a bed sitting room. This appliance is only for use with the gas indicated on the rating plate and may be installed in an aftermarket, permanently located, manufactured (mobile) home where not prohibited by local codes. See owner's manual for details. This appliance is not convertible with other gases, unless a certified kit is used.

WARNING: Improper installation, adjustment, alteration, service, or maintenance can cause injury or property damage. Refer to the owner's information manual provided with this appliance. For assistance or additional information consult a qualified installer, service agency, or the gas supplier. This appliance must be properly connected to a Direct Vent venting system in accordance with the manufacturer's installation instructions.

WARNING: Failure to install this appliance per the manufacturer's instructions or failure to use only parts specifically approved with this appliance may result in property damage or personal injury.

WARNING: Do not operate the appliance until all sections have been assembled and installed in accordance with the manufacturer's instructions.

WARNING: Operation of this appliance when not connected to a properly installed and maintained venting system can result in carbon monoxide (CO) poisoning and possible death.

Only doors certified with the appliance shall be used.
For use with Archgard barrier screen part #62-BS. Follow installation instructions.
Optional Archgard barrier screens available. See the Installation manual for options.

Made in Canada by:
Archgard Industries Ltd.
300 Railway Avenue, Raymond, AB

October 2024 303-3348-01

MANUFACTURE DATE:





Figure 4.0.01:

Installation

5.0 Installation Checklist

This standard installation checklist is to be used by the installer in conjunction with, not instead of, the instructions contained within this installation manual.

Customer: _____	Date Installed: _____
Install Address: _____	Location of Fireplace: _____
	Installer: _____

IHEAT: (See IHEAT Installation, Operation, and Maintenance Manual)	YES	IF NO, WHY NOT?
Do the clearances comply with those specified in the IHEAT manual?		
Does the framing comply with those specified in the IHEAT manual?		
IHEAT venting complies with IHEAT manual?		
Appliance Install: (Section 9.0)	YES	IF NO, WHY NOT?
Top nailing flange extension is installed.		
Fireplace is leveled and secured.		
Venting: (Section 10.0)	YES	IF NO, WHY NOT?
Venting configuration complies with vent diagrams.		
Venting installed and secured in place maintaining proper clearances.		
Maintained 1/4" rise for every 1 ft. on horizontal run.		
Termination is installed and sealed in compliance with local building code.		
Direct vent termination is highest point in vent assembly.		
Wiring / Electrical: (Section 7.0)	YES	IF NO, WHY NOT?
Connected to household 110/120v per local codes.		
Unit is properly grounded.		
Gas: (Section 13.0)	YES	IF NO, WHY NOT?
Proper appliance for fuel type?		
Was a conversion performed?		
Leak check performed & inlet and manifold pressures verified?		
Verified proper air shutter setting?		
Finishing (Section 12.0):	YES	IF NO, WHY NOT?
Only noncombustible material installed in noncombustible areas.		
Clearances meet installation manual requirements.		
Mantels and/or projections comply with install manual.		
Appliance Setup:	YES	IF NO, WHY NOT?
glass door, and screen installed according to this installation manual.		
Burner media installed according to the Media installation manual.		
Manuals given to home owner.		
Did you check operation of lights, fans, and flame modulation?		
Comments:		

6.0 Appliance Overview

6.1 Appliance Overview

The valve and Proflame II control board are located under the valve blind. The valve is located toward the left side of the control area and the control board is in the middle.

The junction box and battery backup (power supply) are located under the valve blind on the right side of the control area (see **Figure 6.1.02**).

The rating plate is attached to the junction box bracket (see **Section 6.2**).

The fans are located on the left and right sides under the firebox and may be accessed through the bottom of the firebox. See **Section 18.15**.

*Left and right side references in this manual correspond with the sides identified in **Figure 6.1.01**.

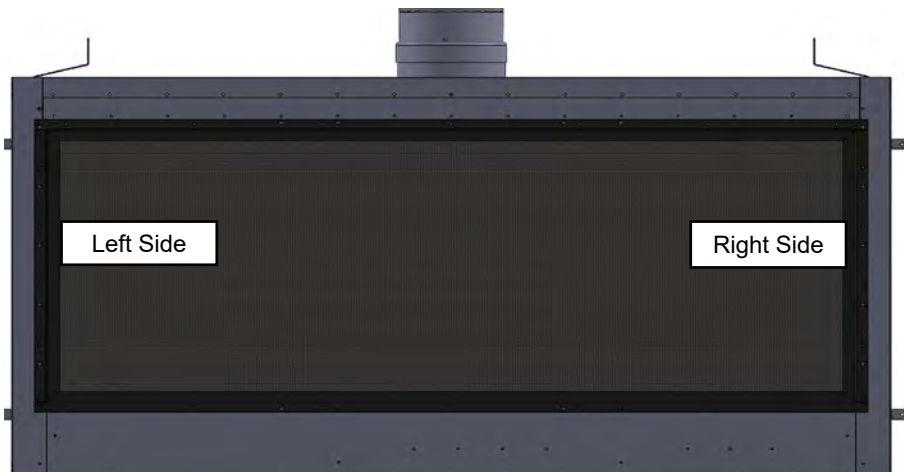

Figure 6.1.01:

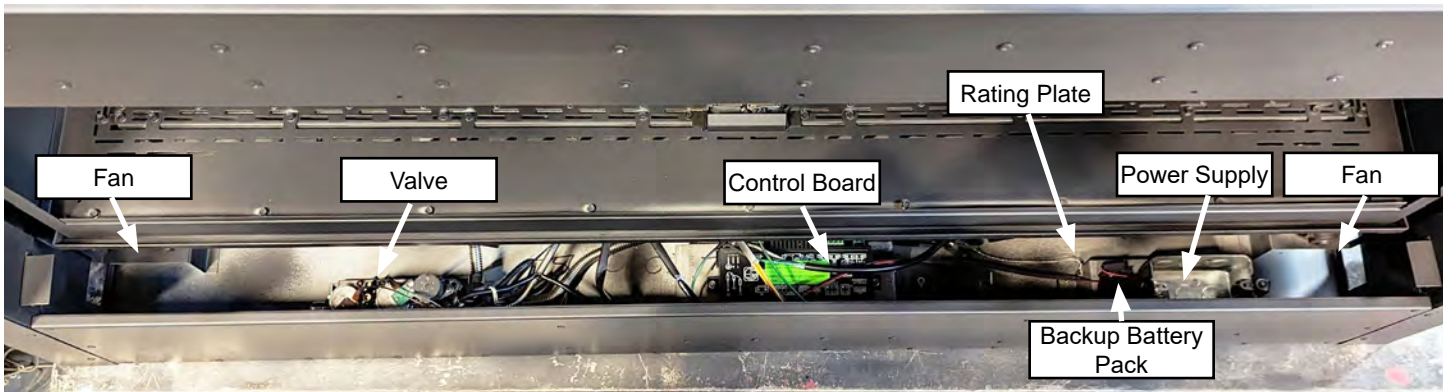

Figure 6.1.02:

The fireplace includes four (4) lifting handles that are designed to slip into slots on each side of the fireplace. This will make lifting and moving the fireplace easier.



Figure 6.1.03:

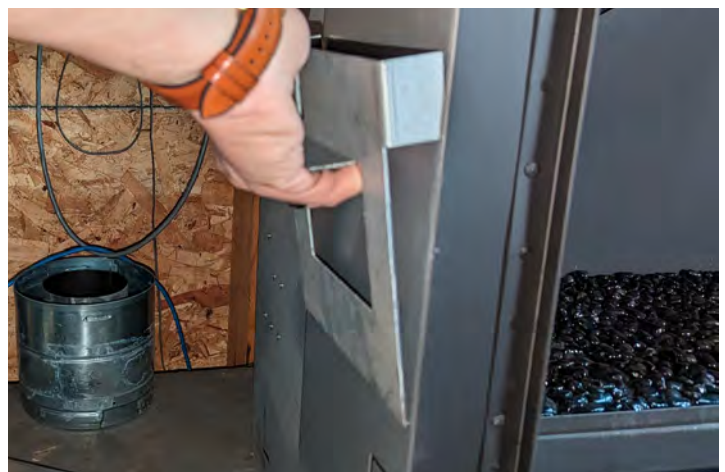

Figure 6.1.04:

Installation

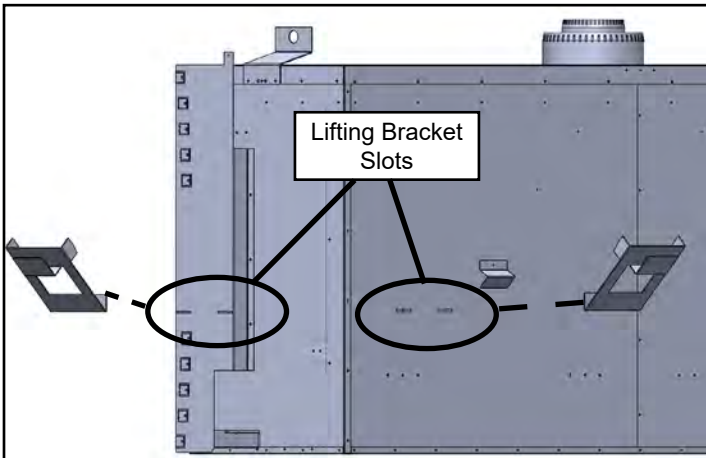

Figure 6.1.05:

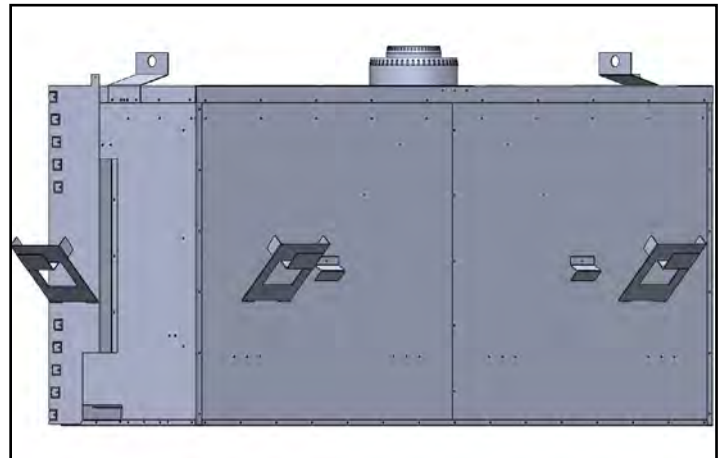

Figure 6.1.06:

6.2 Rating Plate Location

The rating plate is located attached to the junction box bracket. To access the rating plate:

1. Remove the barrier screen (See **Section 6.3**).
2. Remove the Glass Door Assembly (optional - see **Section 6.4**).
3. Remove the Valve Blind (see in **Section 6.5**).

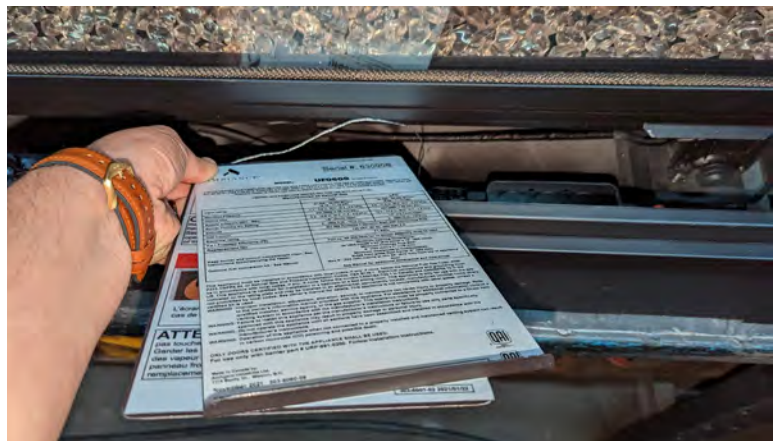

Figure 6.2.01:

Installation

6.3 Barrier Screen (62-BS)

Removal

To remove the screen, gently lift up slightly and pull the screen straight out. The screen is held in place with notched brackets, allowing the screen depth to be adjusted to accommodate the finish material.

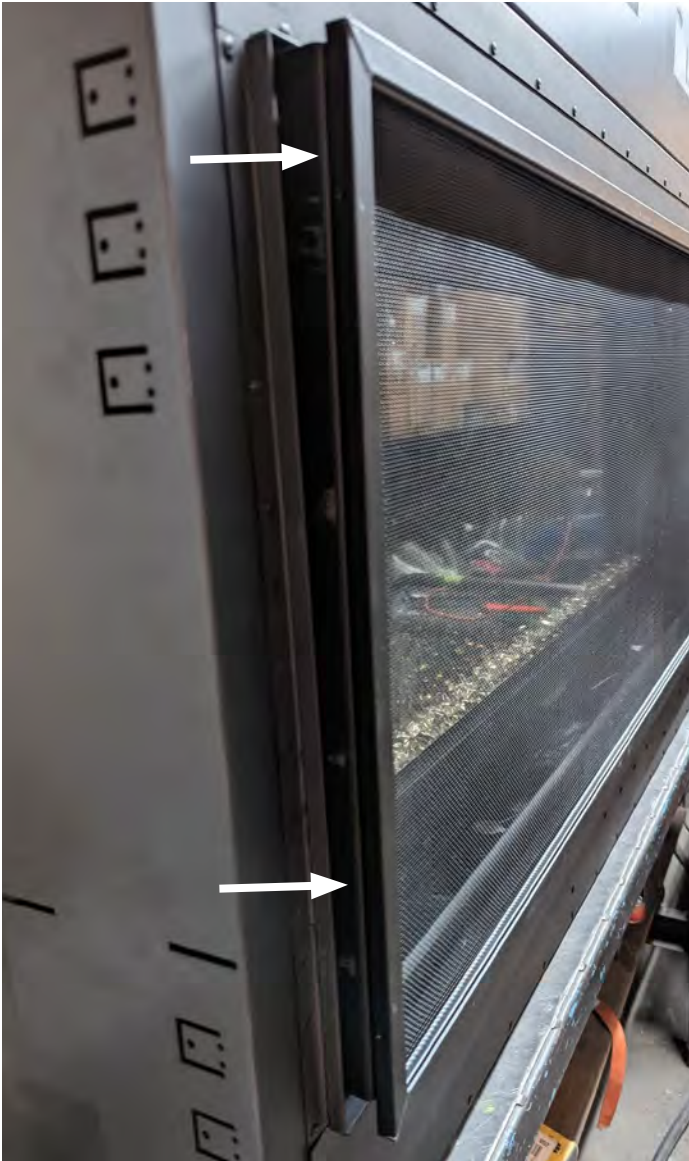

Figure 6.3.01:



Figure 6.3.02: Adjustable Screen

Installation

To install the screen, align the screen with the fireplace opening and push straight in. Gently lift slightly up and slowly push the screen in until it is at the desired depth.

WARNING

DO NOT INSTALL THE BARRIER SCREEN WITH THE GLASS DOOR REMOVED.

If barrier becomes damaged, the barrier shall be replaced with the manufacturer's barrier for this appliance (Part Number: **62-BS**). See the replacement parts list (**Section 20**) for optional front options.

Installation

6.4 Glass Door Installation

WARNING: Do not operate appliance with the glass front removed, cracked, or broken. Replacement of the glass should be done by a licensed or qualified service person. Do not attempt to remove the glass door when the appliance is hot. Be sure there are no fingerprints left on the glass panels during install or when cleaning as high temperatures can bake these prints on permanently. Inspect the door gasket to ensure no damage has occurred when installing the glass door.

Step 01: The door contains three (3) tabs that engage with the lower door bracket. Hold the door at an angle and drop the tabs into the openings in the lower door bracket.



Figure 6.4.01:

Step 02: Rotate the top of the door in. Simultaneously pinch and lift the two (2) upper door buckles to finish the door all the way in.



Figure 6.4.02:

Step 03: Pull the door buckle to engage with the hooks in the top of the door.



Figure 6.4.03:

If Your Glass Breaks

In the event your glass cracks or breaks, replace the original door assembly with Archgard replacement door assembly (part number RP-862-0000). The glass door and frame assembly must be replaced as a complete unit. Remove the barrier screen (See **Section 6.3**) and remove door as per the instructions above. Replace with new door assembly and reinstall the barrier screen.

NOTE: the NEW door will emit some odor when the appliance is lit. The odor will dissipate after the gasket material within the door has cured. Be sure there are no fingerprints left on the glass panels as high temperatures can bake these prints on permanently.

Warning: Only doors certified with the appliance shall be used. Do not use substitute glazing materials.

Installation is the reverse of removal.

Installation

6.5 Accessing The Controls

To access the control board, valve, or backup batteries:

1. Remove the barrier screen (see **Section 6.3**) or decorative front (see **Section 12.5**).
2. Lift the Valve Blind up and out as shown in **Figure 6.5.02** and **Figure 6.5.03**.

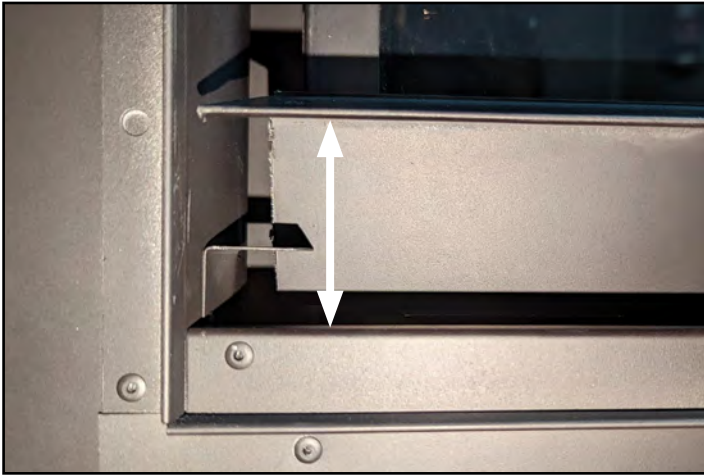

Figure 6.5.01:



Figure 6.5.02:

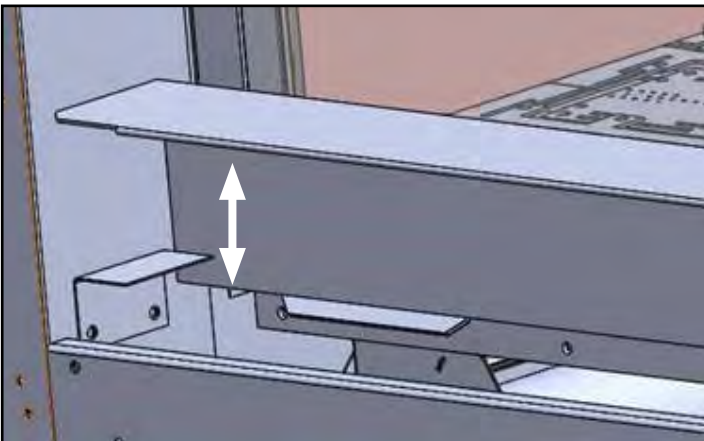

Figure 6.5.03:

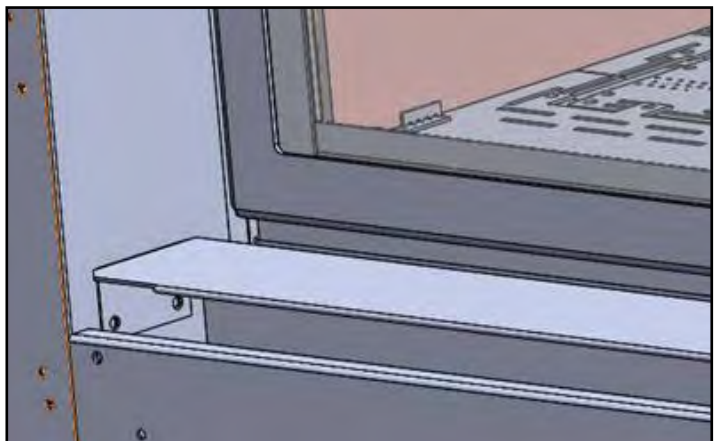

Figure 6.5.04:



Figure 6.5.05:

Installation is the reverse of removal.

Note: When reinstalling the valve blind, the valve blind slides behind the valve blind brackets. See **Figure 6.5.01** through **Figure 6.5.04**. Ensure the valve blind is centered so that it does not impede installation of the barrier screen or decorative front.

Installation

7.0 Electrical Connections

The **62-DVTE46CN-1** comes complete with two adjustable 6 speed fans and variable lights wired directly to the main control module. Do not cut or remove the grounding prong from the main power supply plug.

CAUTION: Label all wires prior to disconnection when servicing.

NOTE: This appliance, when installed, must be electrically grounded in accordance with local codes or, in the absence of local codes, with the National Electrical Code, ANSI / NFPA 70, or the Canadian Electrical code, CSA C22.1.

Before you begin:

- Remove the barrier screen (see **Section 6.3**)
- Remove the Valve Blind (see in **Section 6.5**)
- Remove the glass door assembly (optional - see **Section 6.4**)

To supply power to the fireplace:

Step 01: Pass the household wiring through the opening on the right side of the fireplace.

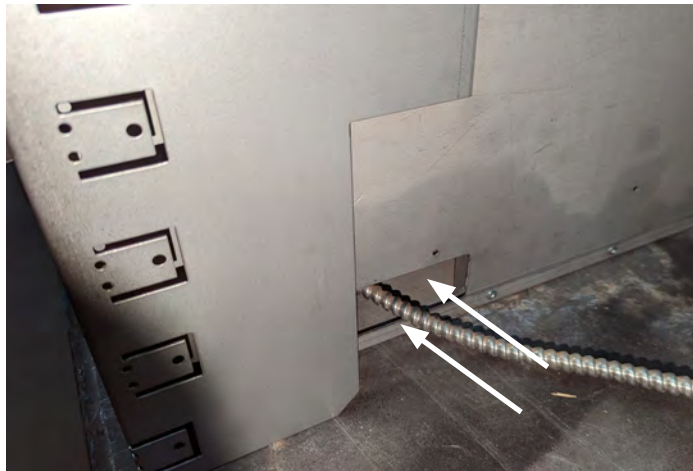

Figure 7.0.01:

Step 03: Pass the wire through the strain relief and secure in place. Wire according to local code using the receptacle and electrical plate included with this fireplace.

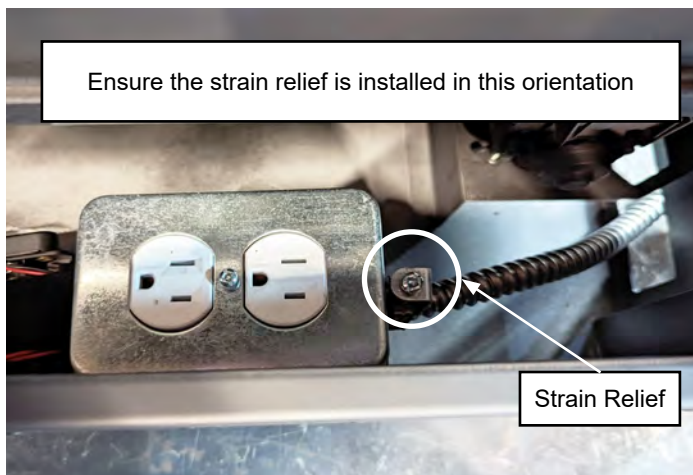

Figure 7.0.03:

Step 02: The junction box is located on the right side of the control board. It may be removed by removing the two (2) 1/4" Tek Screws if necessary.

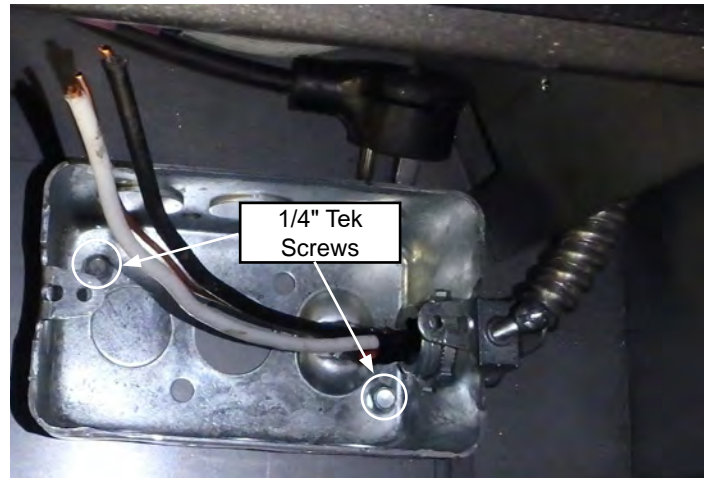

Figure 7.0.02:

Step 04: Plug the three-pronged plug from the control board into the receptacle.



Figure 7.0.04:

8.0 Fireplace Dimensions

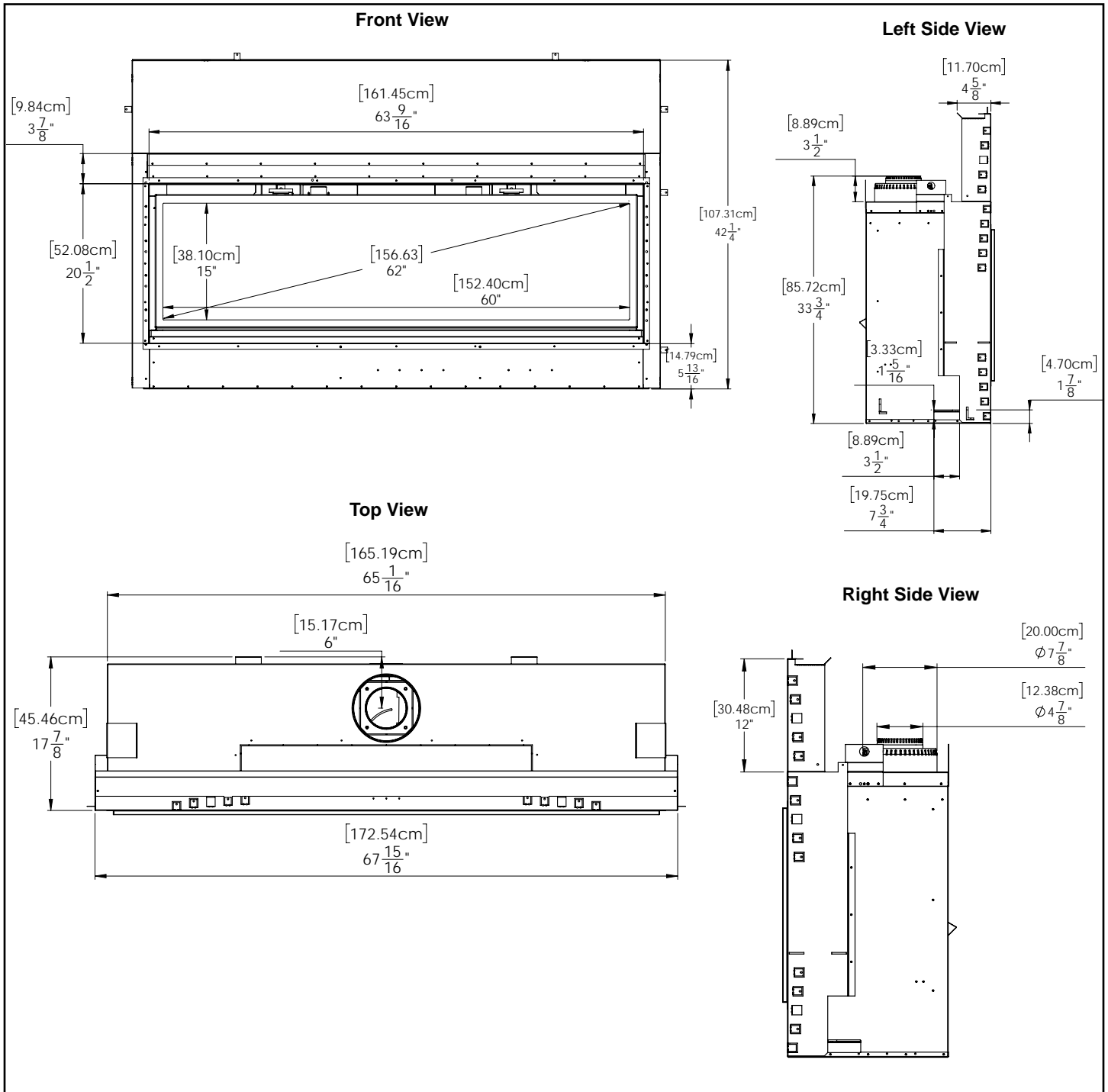

Figure 8.0.01:

Installation

9.0 Prepare The Fireplace

9.1 Installation Overview

NOTE

This product must be installed by a qualified installer. The installer should follow the procedure best suited for each specific installation.

IMPORTANT

**Appliance clearances and framing specifications differ if IHEAT is installed.
See the IHEAT manual before planning your installation.**

1. Frame an opening for the fireplace (see the IHEAT manual if installing IHEAT), allowing for vent installation and type of installation.
2. If mounting a heat sensitive object such as a television or artwork above the fireplace, you must also install IHEAT. See IHEAT manual for clearance changes when using IHEAT.
3. Attach nailing flange extension and header heat shield.
4. Bend nailing flange tabs.
5. Insert fireplace into framing.
6. Install hearth (if applicable).
7. Complete electrical hook-up.
8. Complete gas line installation.
9. Complete venting installation.
10. Secure fireplace to framing. Verify all clearances.
11. Install facing material (refer to **Section 12** for clearance information), mantel or cabinetry.
12. Install the optional panel set. Many options are available from your local Archgard dealer.
13. Install the burner media, glass door assembly, valve blind, and barrier screen.
14. Verify proper operation of fireplace and all components.

PLACEMENT CLEARANCE REQUIREMENTS

- This fireplace must be installed on a level surface capable of supporting the fireplace and venting
- Fireplace must be placed directly on wood or non-combustible surface (not linoleum or carpet) extending entire depth and width of fireplace
- Facing material must be all non-combustible (see **Section 12** for detailed clearance information)
- Due to high surface temperatures, fireplace should be located out of traffic and away from furniture and draperies
- This fireplace may be installed in a bedroom (see local codes)
- Please be aware of the large amount of heat this fireplace will produce when determining a location

9.2 Nailing Flange Tabs

Side Nailing Flanges

Bend the nailing tabs that corresponds with the thickness of the facing material being used (see **Figure 9.2.01** and **Figure 9.2.02**).

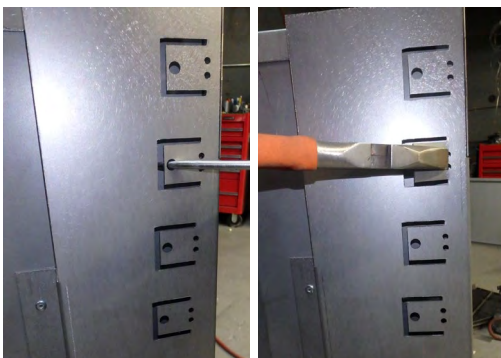

Figure 9.2.01:

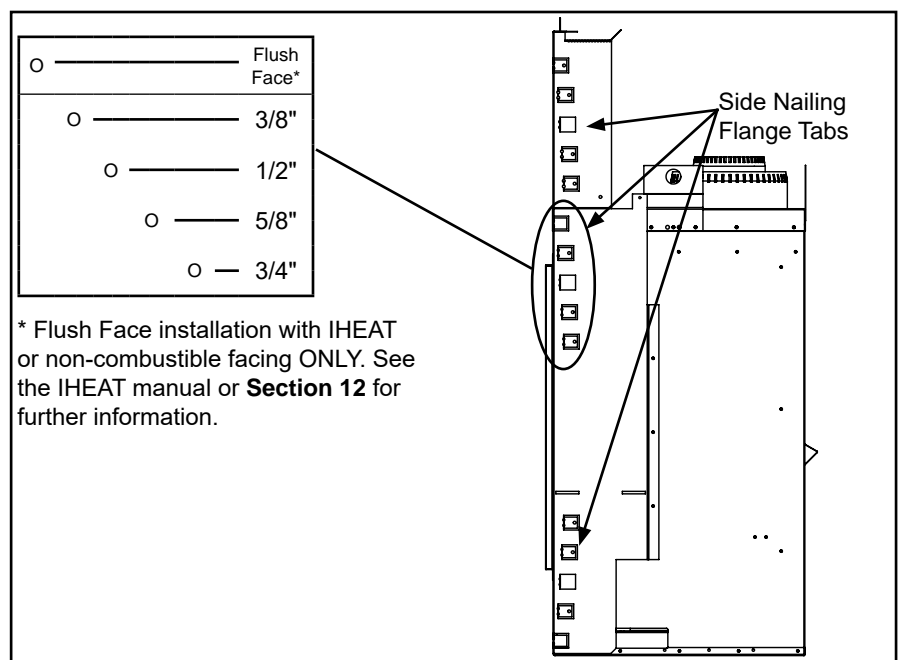

Figure 9.2.02:

9.3 Nailing Flange Extension

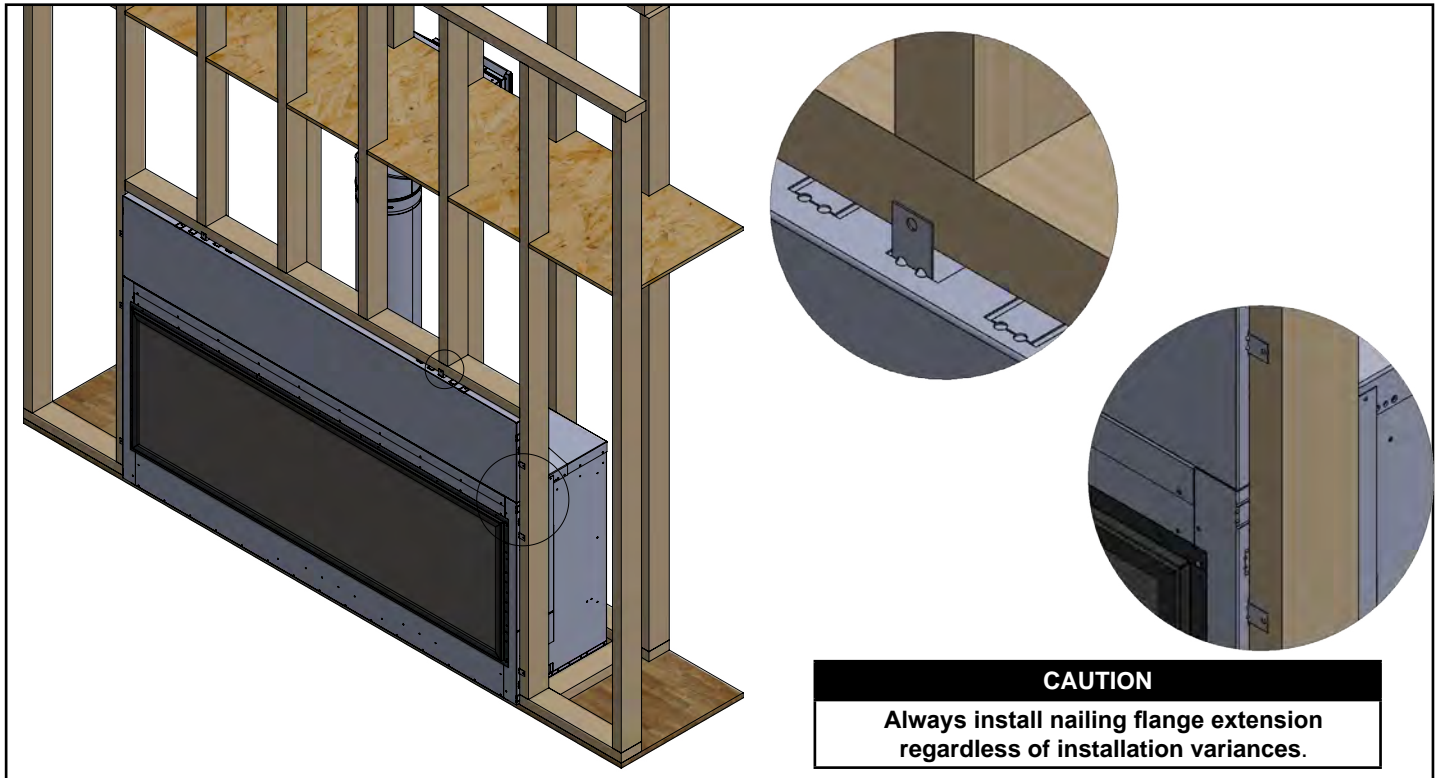

Figure 9.3.01:

Attaching The Nailing Flange Extension

Attach the nailing flange extension to the top of the fireplace using the five (5) 1/4" tek screws included in the manual bag.

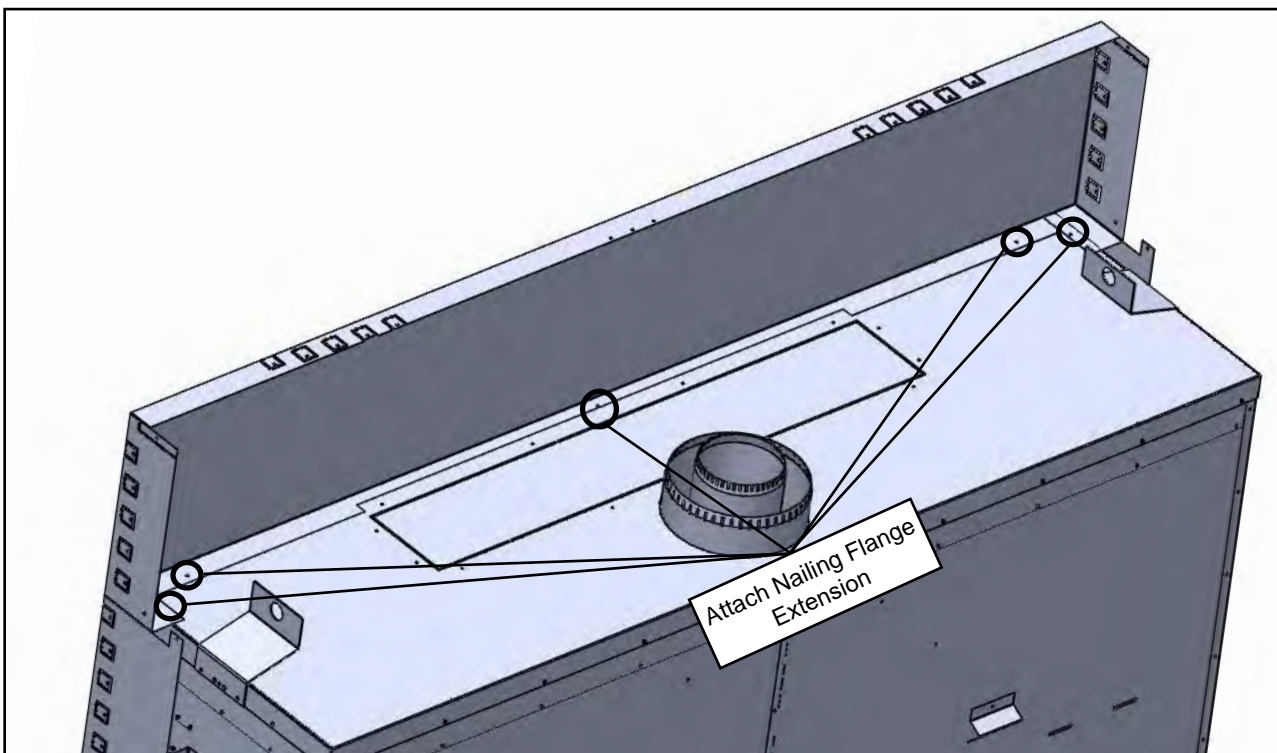

Figure 9.3.02:

Installation

Header Heat Shield Tabs

Bend the header heat shield tabs in at approximately a 90° angle (see **Figure 9.3.03**).

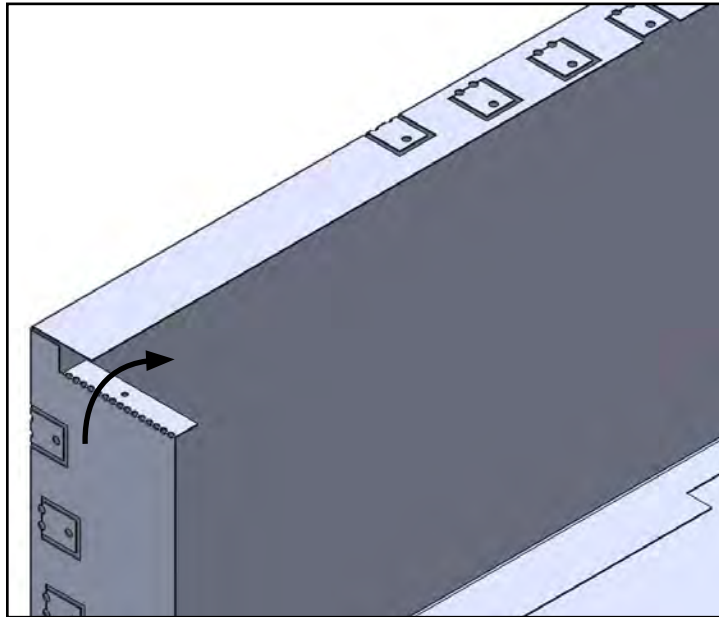

Figure 9.3.03:

Place the header heat shield on the header heat shield tabs.
Note: The header heat shield is not necessary if installing IHEAT.

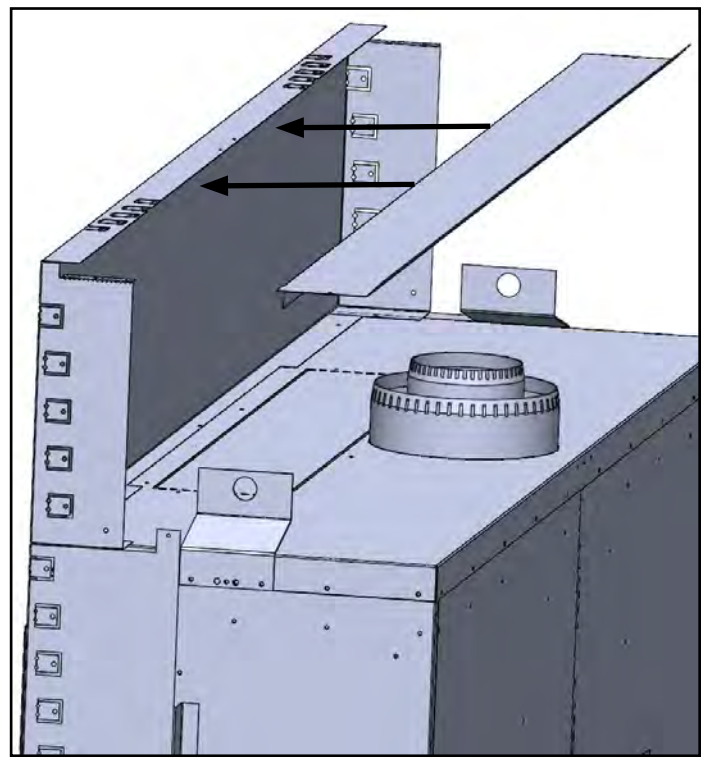

Figure 9.3.04:

Attach the header heat shield to the header heat shield tabs using two (2) 1/4" tek screws included in the manual bag.

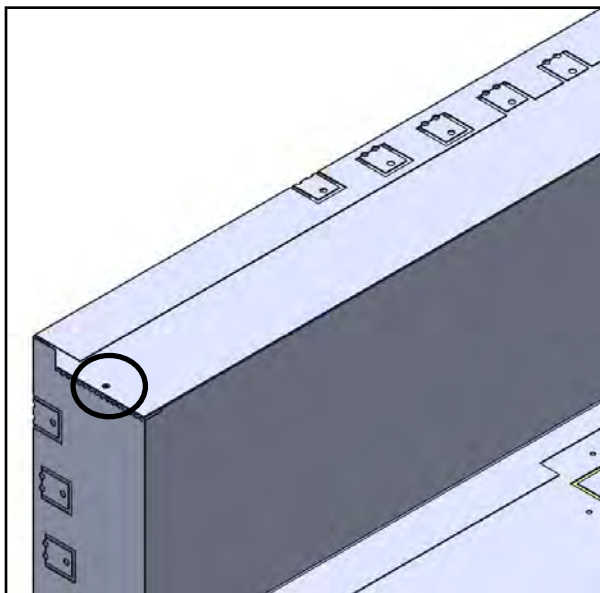

Figure 9.3.05:

Top Nailing Flange Tabs

Bend the nailing tabs that correspond with the thickness of the facing material being used (see **Figure 9.3.06**).

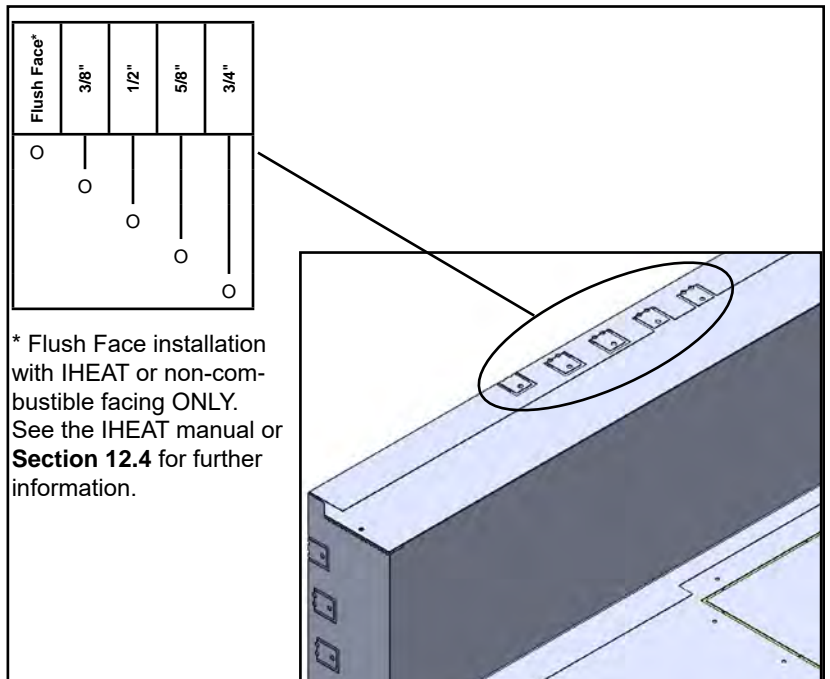

Figure 9.3.06:

Installation

10.0 Venting Instructions

WARNING: Operation of this heater when not connected to a properly installed and maintained venting system can result in carbon monoxide (CO) poisoning and possible death. The appliance must not be connected to a chimney flue serving a separate solid fuel burning appliance.

WARNING

Consult the local and international codes to assure adequate combustion and ventilation air is available. Flame height and appearance will vary depending upon venting configuration and type of fuel used. Venting requirements apply to both Natural and LP gas.

Refer to the vent manufacturer's installation manual for complete installation instructions. Installation must conform with the venting requirements and restrictions as outlined in this manual. Provide a means for visually checking vent connection to fireplace after fireplace is installed.

(2) 45° degree elbows may be used in place of (1) 90° elbow. Always maintain a minimum 12" (305 mm) span between each 90° bend in the vent run.

IF INSTALLING FLEX PIPE SYSTEMS:

- More than a 30 degree bend constitutes a 45 degree elbow
- More than a 45 degree bend constitutes a 90 degree elbow
- More than a 90 degree bend is not permissible
- Refer to vent manufacturer's installation manual for more information.

DO NOT USE SILICONE TO SEAL VENT.

Horizontal Venting Specifications:

- Horizontal sections require 1/4" (6 mm) rise for every 12" (305 mm) of travel
- Horizontal sections must be supported to prevent sagging. See vent manufacturer's installation manual for more information - As a general guideline; a flex line should be supported every 2 - 3' (609.6 - 914.4 mm) and rigid pipe should be supported every 4 - 6' (1219.2 - 1828.8 mm)
- This fireplace must be installed so as to prevent accumulation of condensate in the venting system

A wall thimble / firestop must be used when penetrating a combustible wall.

A reducer from 5 x 8 to 4 x 6 $\frac{5}{8}$ may be used as long as the venting meets specifications shown in **Section 10.1**. **Note:** An adapter may be required before reducing depending on the venting manufacturer.

Important: An adapter may required for either 5 x 8 or 4 x 6 $\frac{5}{8}$ depending on the manufacturer. See **Section 10.4** or **Section 10.5** for part numbers depending on your venting setup.

Manufacturer	Part Number
Duravent	Not Required
ICC	Required
Selkirk	Required
Amerivent	Required

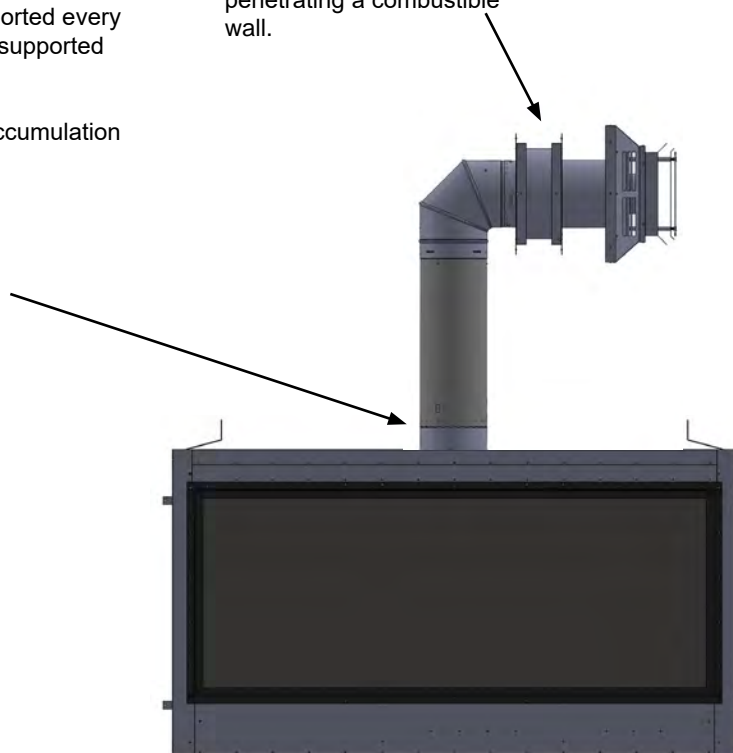

Figure 10.0.01:

Installation

5 x 8 or 4 x 6⁵/₈ Typical Venting Configuration

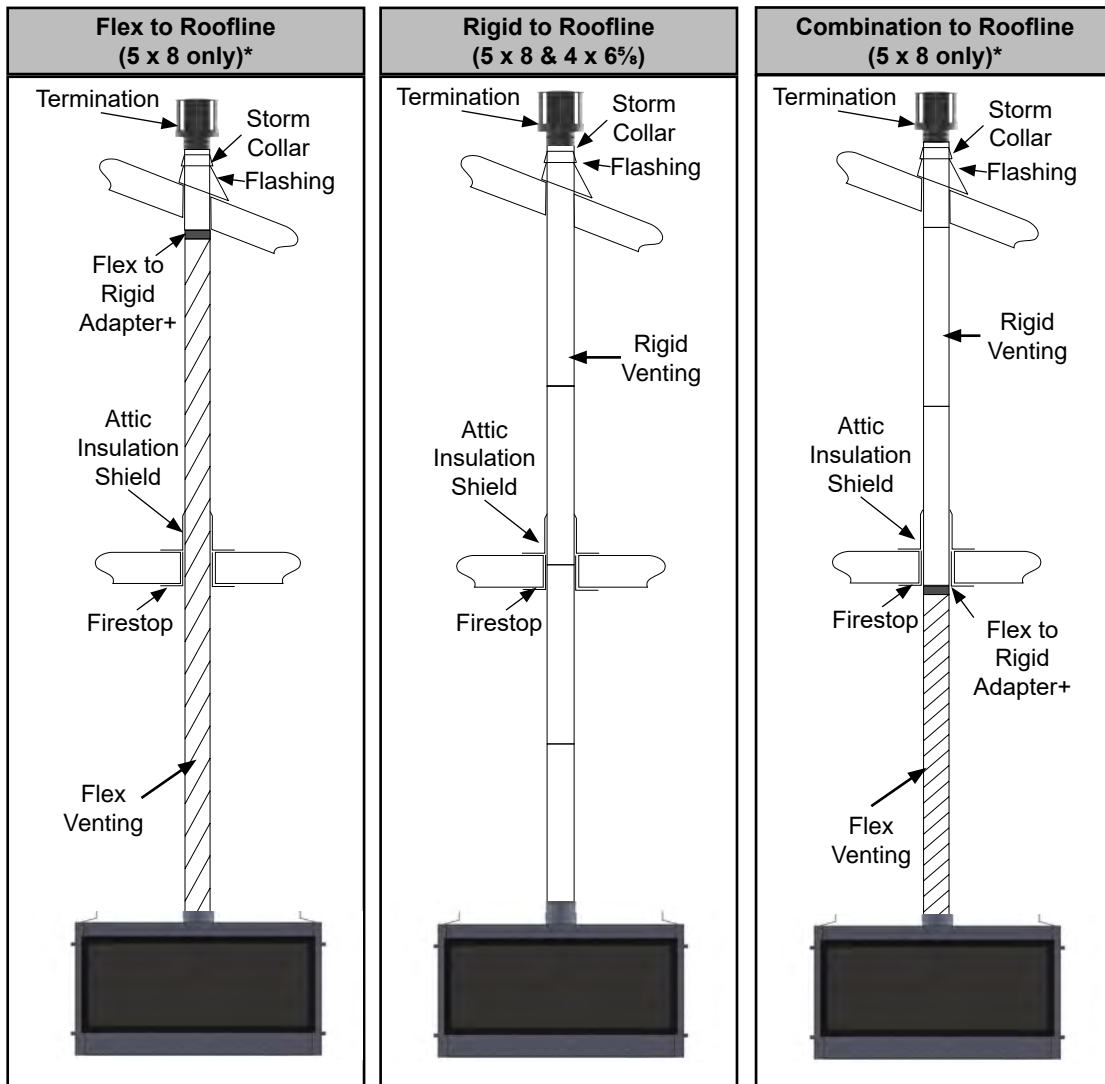

Figure 10.002:

* Archgard is not aware of a 5 x 8 to 4 x 7 flex adapter. If one exists, vertical flex is possible. Follow the vent chart in **Section 10.1** and **Section 10.2**.

+ See vent manufacturer for part number for adapter.

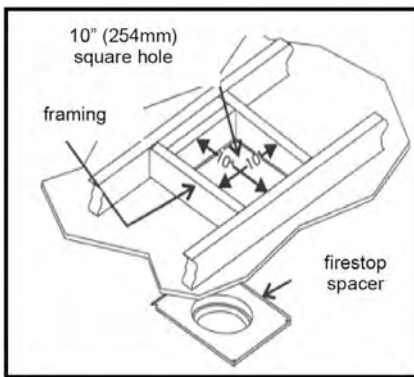

Figure 10.003: 4" x 6⁵/₈" Firestop Framing

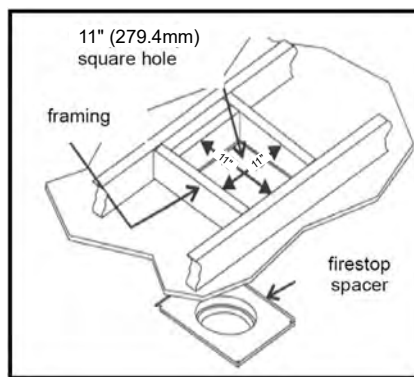

Figure 10.004: 5" x 8" Firestop Framing

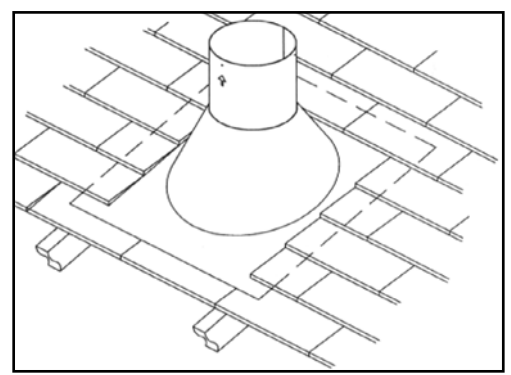

Figure 10.005: Flashing Installation

Installation

10.1 Vent Run Guide: 4" x 6⁵/₈" Rigid or 4" x 7" Flex Pipe

Horizontal Vent Sections rise 1/4"/ft (21mm/m)

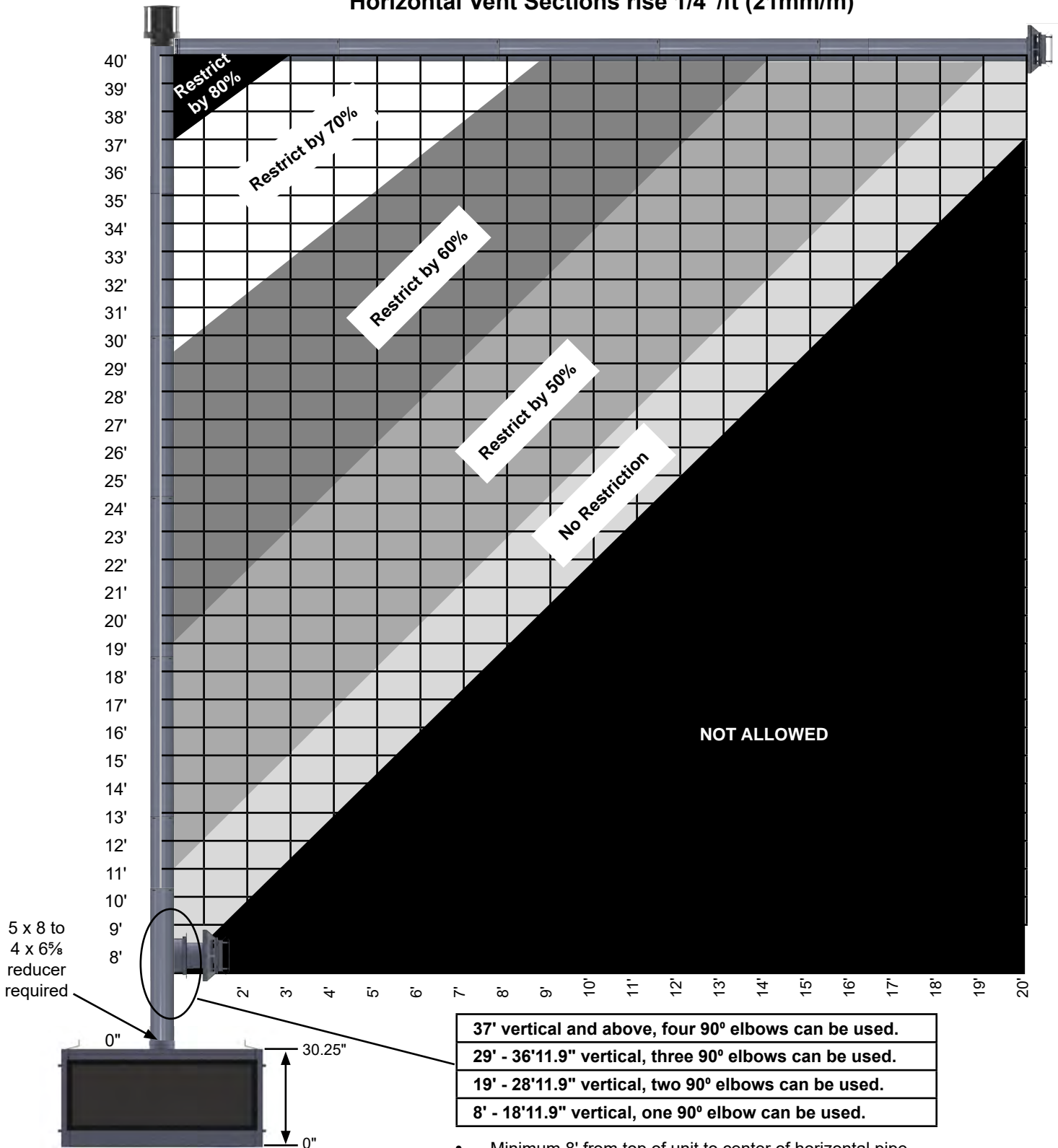

Figure 10.1.01:

- Minimum 8' from top of unit to center of horizontal pipe
- Vent height is measured from the top of the fireplace
- Nailing flange extension is not shown installed for clarity
- Two 45° elbows = one 90° elbow
- See Section 10.7 for snorkel use

Installation

10.2 Vent Run Guide: 5" x 8" Rigid or Flex Pipe

Horizontal Vent Sections rise 1/4"/ft (21mm/m)

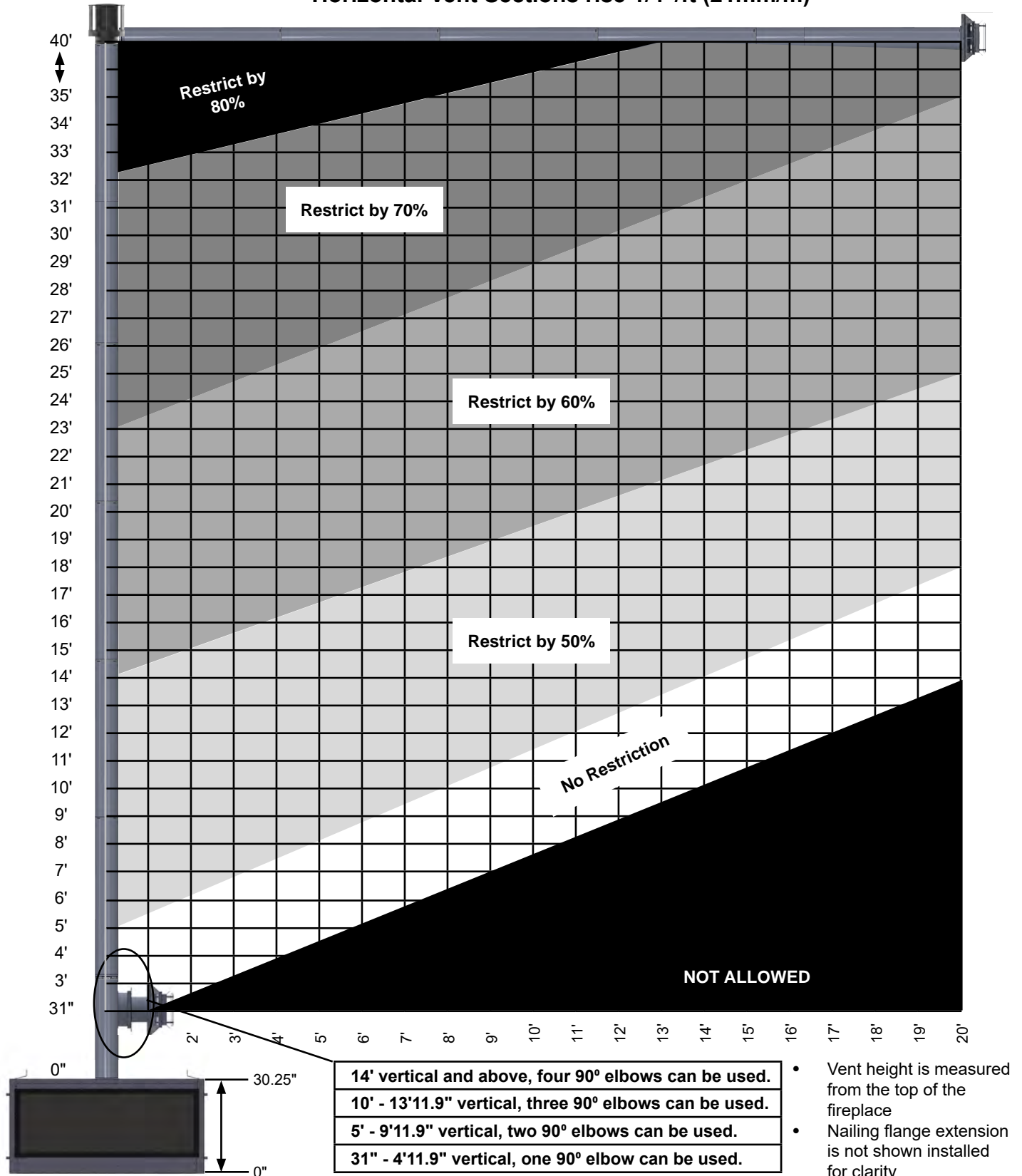

Figure 10.2.01:

- Vent height is measured from the top of the fireplace
- Nailing flange extension is not shown installed for clarity
- Two 45° elbows = one 90° elbow
- See **Section 10.7** for snorkel use

Installation

10.3 Vent Restrictor Configuration

This fireplace is shipped with the restrictor plate installed in the 0% restricted setting. Follow the chart in **Section 10.1** or **Section 10.2** for recommended settings based on venting configuration. It is important to remember each installation is unique and affected by various factors including venting configuration, altitude and climate. Therefore, after fireplace installation is complete, restrictor adjustments may be necessary. Use the following steps to adjust the vent restrictor.

Before you begin:

- **Disconnect power supply to the fireplace (including backup batteries)**
- Remove the barrier screen (see **Section 6.3**)
- Remove the valve blind (see **Section 6.5**)
- Remove the glass door assembly (see **Section 6.4**)
- Remove the firebox liner (see **Section 15**)
- Remove the baffle (see **Section 18.12**)

Step 01: Attach the restrictor using the 1/4" Tek Screw from the manual bag included with the fireplace.

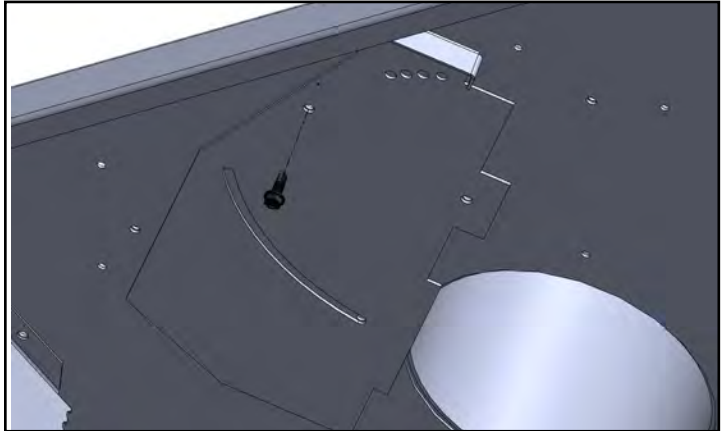

Figure 10.3.01:

Step 02: Set the restrictor according to the chart below and secure using a 1/4" Tek Screw from the manual bag included with the fireplace.

Restrictor Setting	Hole Pattern	
0% Restricted		
50% Restricted		
60% Restricted		
70% Restricted		
80% Restricted		

Figure 10.3.02:

Installation

10.4 Third Party Venting Components (4 x 6^{5/8})

ATTENTION

NO OTHER VENTING SYSTEM OR COMPONENTS MAY BE USED.

Part numbers shown are correct at the time of printing and should be confirmed with the manufacturer prior to purchase.

Follow manufacturer instructions for installation of termination.

	Selkirk	Duravent	ICC	Amerivent
Adapter Required before reducing				
Adapter	5DT-AAN	Not Required	TM-5AA6	5DT-AAN
Reducer: 5" x 8" to 4" x 6^{5/8}"				
Venting Reducer	5DT-R4	58DVA-X46	5DT-R4	---
4" x 6^{5/8}" Hard Pipe				
6"	4DT-06	46DVA-06	4DL6	4D7 (7")
9"	4DT-09	46DVA-09	4DL9	---
12"	4DT-12	46DVA-12	4DL1	4D12
18"	4DT-18	46DVA-18	---	---
24"	4DT-24	46DVA-24	4DL2	4D2
36"	4DT-36	46DVA-36	4DL3	4D3
48"	4DT-48	46DVA-48	4DL4	4D4
60"	---	46DVA-60	---	---
4" x 6^{5/8}" Pipe Extension				
Short Extension	4DT-AJ12 (4" to 10")	46DVA-08A (3" to 7")	4DLS1 (1 7/8" to 9")	4D7A (3" to 5")
Long Extension	---	46DVA-16A (3" to 14 1/2")	4DLS2 (1 7/8" to 21")	4D12A (3" to 10")
	---	---	---	4D16A (3" to 14")
	---	---	---	4D26A (3" to 24")
4" x 6^{5/8}" Adjustable (Telescopic) Pipe				
Short Adjustable	4DT-TL14 (14" to 22")	46DVA-17TA (9 1/2" to 15 1/2")	---	---
Long Adjustable	4DT-TL38 (38" to 70")	46DVA-24TA (15 1/2" to 22 1/2")	4DLA30 (16 1/2" to 29")	---
4" x 6^{5/8}" Hard Elbows				
30 degree	---	46DVA-E30	---	---
45 degree	4DT-EL45	46DVA-E45	4DE45	4D45L
60 degree	---	46DVA-E60	---	---
90 degree	4DT-EL90S	46DVA-E90	4DE90	4D90L
Slip 90 Degree Elbow	---	---	4DE90S	---
Wall Strap	4DTWS/B	46DA-WS	4WS	4DWS
Elbow (Offset) Strap	4DT-OS	46DVA-ES	4OS	4DWS
Wall Thimble	4DT-WT	46-DVA-WT	4WT	4DWT
Vinyl Siding Standoff	4DT-VSK (For 4DT-HCR) 4DT- VS or 4DTVSS (For 4DT-HC)	46DVA-VSS	4VSS	4DVSK (For 4DHC) 4DHVS or 4DHVSK (For 4DHCS)
Counter Flashing	---	46DVA-CFK	---	---
Counter Flashing Stainless	---	46DVA-CFK-S	---	---
Ceiling Firestop	4DT-CS	46DVA-FS	4CS	4DFSP
Attic Insulation Shield	4DT-AIS	46-DVA-IS	4AS	4DAIS12

Installation

Third Party Venting Components (4 x 6⁵/₈ - cont'd)

	Selkirk	Duravent	ICC	Amerivent
Roof Flashings				
0/12 to 6/12 Pitches	4DT-AF6	46DVA-F6	4FA (1/12 to 7/12)	4DF (0/12 to 5/12)
7/12 to 12/12 Pitches	4DT-AF12	46DVA-F12	4FB (8/12 to 12/12)	4DF12 (6/12 to 12/12)
Flat Roof	---	46DVA-FF	4F	---
Metal Roof Flashings				
0/12 to 6/12 Pitches	URBAK (rubber boot flashing)	46DVA-F6DS	---	URBAK (rubber boot flashing)
7/12 to 12/12 Pitches	URBAK (rubber boot flashing)	46DVA-F12DS	---	URBAK (rubber boot flashing)
Storm Collar	4DT-SC	46DVA-SC	4SC	4DSC
Horizontal Terminations				
Horizontal Square Termination (Aluminum)	4DT-HC	46DVA-HC	TM-4HT	4DHCS
Horizontal Square Termination (Stainless)	---	46DVA-HC-S	---	---
Horizontal Square Termination (Copper)	---	46DVA-HC-C	---	---
Horizontal Termination Other			TM-4DHT	
Horizontal Round Termination (Aluminum)	4DT-HCR	46DVA-HRCS	---	4DHC
Snorkels				
14" Snorkel	4DT-ST14	46DVA-SNK14	4ST14	4D14S
36" Snorkel	4DT-ST36	46DVA-SNK36	4ST36	4D36S
Horizontal High Wind Guard	---	46-DVA-WG	---	4DHWS
Vertical Terminations				
Vertical High Wind Termination	4DT-VT	46DVA-VCH (Archgard Part # 999-DV-SDVTC)	TM-4SVT	4DVC
Vertical High Wind Guard	---	46DVA-VWG	4SVTS	---
Flex Venting				
7" 25ft	1770250	7DFA-25	---	1770250
7" 35ft	1770350	7DFA-35	---	1770350
7" 50ft	---	7DFA-50	---	---
4" 25ft	1740250	4DFA-25	---	1740250
4" 35ft	1740350	4DFA-35	---	1740350
4" 50ft	---	4DFA-50	---	---

Archgard Flex Vent Kit	
999-DV-FL4710	Includes 4" & 7" aluminum flex liner (10' long) with six springs.
999-DV-C47	Includes 7" flex liner coupler (312-0025), and 4" flex liner coupler (312-0024).

Horizontal Safety Cages		
Archgard	999-DV-SCU	Termination Safety Cage - Universal (14 ³ / ₄ " W x 14 ³ / ₄ "H x 10 ¹ / ₄ "D)
ICC	4HTS	ICC Horizontal Termination Safety Cage

Installation

10.5 Third Party Venting Components (5 x 8)

	Selkirk	Duravent	ICC	Amerivent
Adapter				
Adapter	5DT-AAN	Not Required	TM-5AA6	5DT-AAN
5" x 8" Hard Pipe				
6"	5DT-06	58DVA-06	5DL6	5D7 (7")
9"	5DT-09	58DVA-09	5DL9	---
12"	5DT-12	58DVA-12	5DL1	5D12
18"	5DT-18	58DVA-18	---	---
24"	5DT-24	58DVA-24	5DL2	5D2
36"	5DT-36	58DVA-36	5DL3	5D3
48"	5DT-48	58DVA-48	5DL4	5D4
60"	---	58DVA-60	---	---
5" x 8" Pipe Extension				
Short Extension	5DT-AJ12 (4" to 10")	58DVA-08A (3" to 7")	5DLS1 (1 7/8" to 9")	5D7A (3" to 5")
Long Extension	---	58DVA-16A (3" to 14 1/2")	5DLS2 (1 7/8" to 21")	5D12A (3" to 10")
	---	---	---	5D16A (3" to 14")
	---	---	---	5D26A (3" to 24")
5" x 8" Adjustable (Telescopic) Pipe				
Short Adjustable	---	58DVA-17TA (9 1/2" to 15 1/2")	---	---
Long Adjustable	---	58DVA-24TA (15 1/2" to 22 1/2")	DLA30 (16 1/2" to 29")	---
5" x 8" Hard Elbows				
30 degree	---	58DVA-E30	5DE30	---
45 degree	5DT-EL45	58DVA-E45	5DE45	5D45L
60 degree	---	58DVA-E60	---	---
90 degree	5DT-EL90	58DVA-E90	5DE90	5D90L
Slip 90 Degree Elbow	---	---	5DE90S	---
Wall Strap	5DT-WS/B	58DA-WS	WS (universal)	5DWS
Elbow (Offset) Strap	5DT-OS	58DVA-ES	OS (universal)	5DWS
Wall Thimble	5DT-WT / 5DT-WT-1	58DVA-WT	5WT	5DWTS / 5DWT
Vinyl Siding Standoff	5DT-VSK / 5DT-VSKB (for 5DT-HCR) 5DT-VSS / 5DT- VSSB or 5DT-VS / 5DT-VS-1 (for 5DT-HC)	58DVA-VSS	VSS (universal)	5DHVSB / 5DH- VSK or 5DVSL (for 5DHCS) 5DVSB or 5DVSK (for 5DHC)
Counter Flashing	---	58DVA-CFK	---	---
Counter Flashing Stainless	---	58DVA-CFK-S	---	---
Firestop Spacer	5DT-FS	---	---	---
Ceiling Firestop	5DT-CS	58DVA-FS	5CS	5DFSP
Attic Insulation Shield	5DT-AIS	58DVA-IS	5AS	5DAIS12 or 5DAIS36

Installation

Third Party Venting Components (5 x 8 - cont'd)

	Selkirk	DuraVent	ICC	Amerivent
Roof Flashings				
0/12 to 6/12 Pitches	5DT-AF6	58DVA-F6	6EFA (1/12 to 7/12)	5DF (Flat to 5/12)
6/12 to 12/12 Pitches	5DT-AF12	58DVA-F12	6EFB (8/12 to 12/12)	5DF12
Flat Roof	---	58DVA-FF	6EF (Flat - 2/12)	---
Metal Roof Flashings				
0/12 to 6/12 Pitches	URBAK (rubber boot flashing)	58DVA-F6DS	6EMFA	TLCRBF or TLCMRFK
7/12 to 12/12 Pitches	URBAK (rubber boot flashing)	58DVA-F12DS	6EMFB	TLCRBF or TLCMRFK
Storm Collar	5DT-SC	58DVA-SC	SC (universal)	5DSC
Horizontal Terminations				
Horizontal Square Termination (Aluminum)	5DT-HC / 5DT-AHC	58DVA-HC	TM-5HT	5DAHCS or 5DHCS
Horizontal Square Termination (Stainless)	---	58DVA-HC-S	---	---
Horizontal Square Termination (Copper)	---	58DVA-HC-C	---	---
Horizontal Termination Other	---	---	TM-5RHT	---
Horizontal Round Termination (Aluminum)	5DT-HCR	58DVA-HRCS	---	5DHC
Snorkels				
14" Snorkel	5DT-ST14	58DVA-SNK14	5ST14	5D14S
36" Snorkel	5DT-ST36	58DVA-SNK36	5ST36	5D36S
Horizontal High Wind Guard	---	58DVA-WG	5HTS / 5RHTS	5DHWS
Vertical Terminations				
Vertical High Wind Termination	5DT-VT or 5DT-VC	58DVA-VCH	5SVT	5DVC
Vertical High Wind Guard	---	46DVA-VWG	5SVTS	---
Flex Venting				
8" 25ft	1780250	8DFA-25	---	1780250
8" 35ft	1780350	8DFA-35	---	1780350
8" 50ft	---	8DFA-50	---	---
5" 25ft	1750250	8DFA-25	---	1750250
5" 35ft	1750350	8DFA-35	---	1750350
5" 50ft	---	8DFA-50	---	---

Horizontal Safety Cages		
Archgard	999-DV-8SCU	Termination Safety Cage - Universal (17½" W x 17½" H x 10½" D)

ATTENTION

NO OTHER VENTING SYSTEM OR COMPONENTS MAY BE USED.

Part numbers shown are correct at the time of printing and should be confirmed with the manufacturer prior to purchase.

Follow manufacturer instructions for installation of termination.

Installation

10.6 Termination Location Clearances

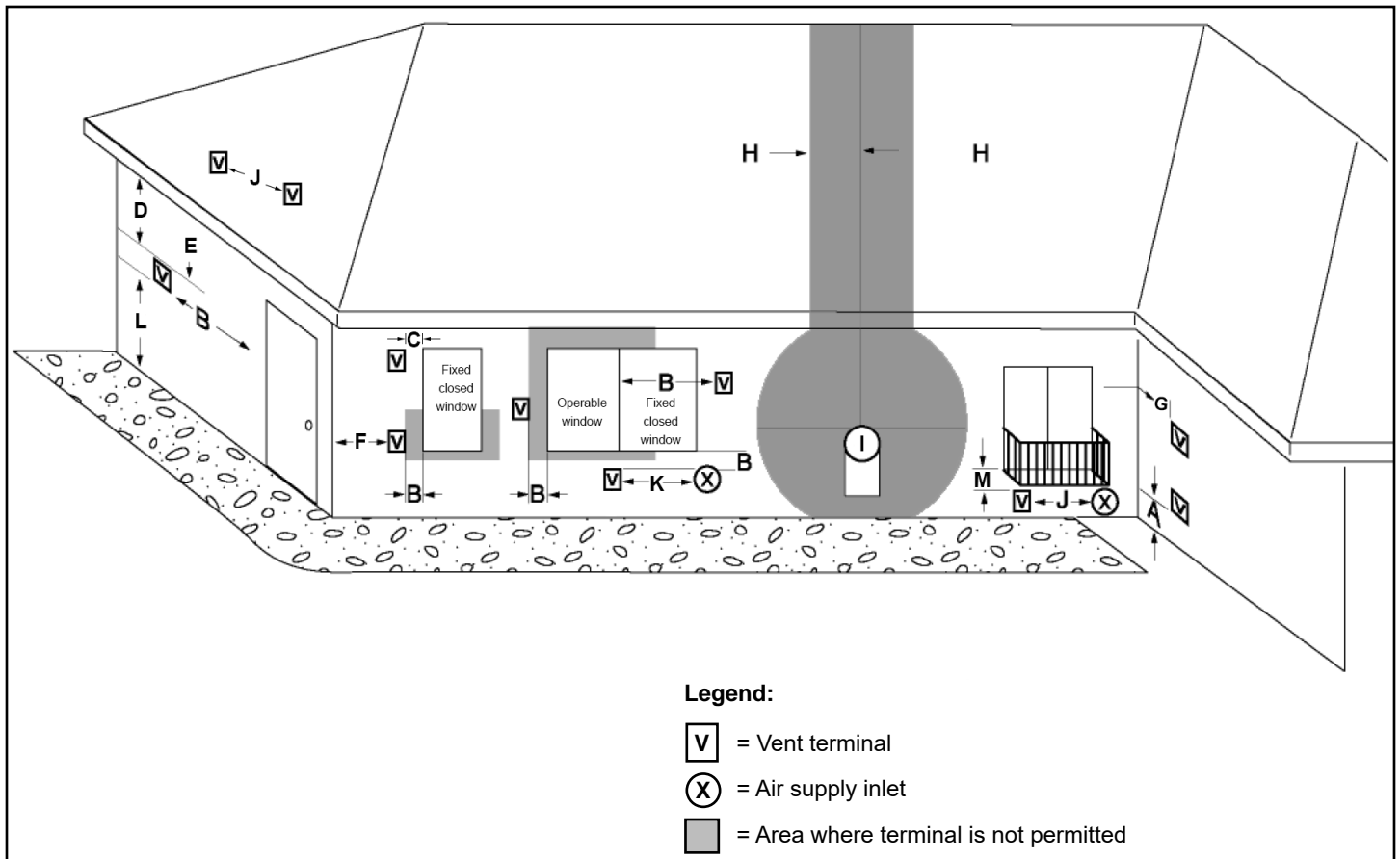

Figure 10.6.01:

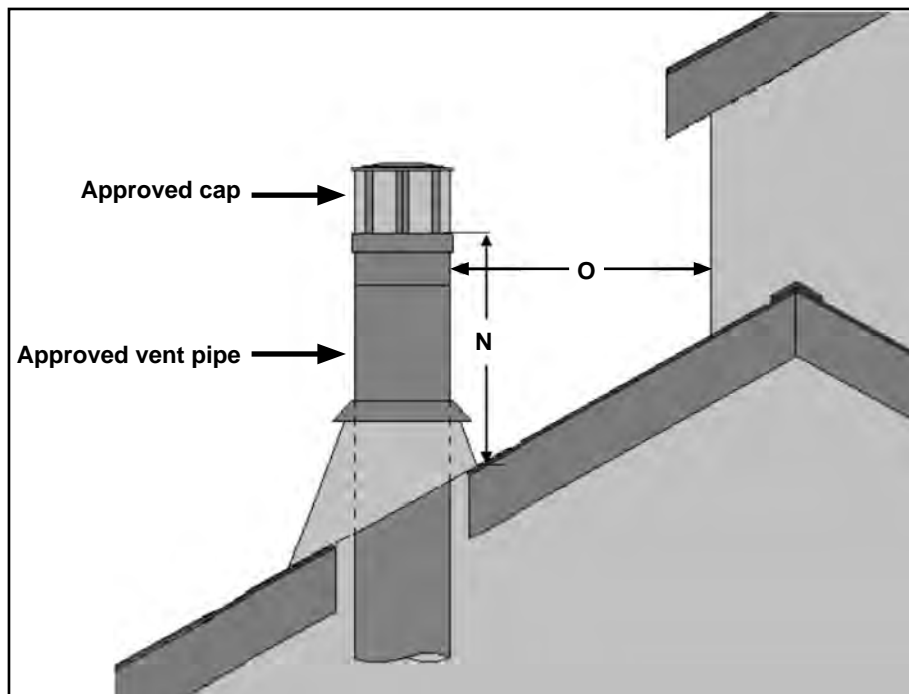

Figure 10.6.02:

Installation

		Canadian Installations ¹	US Installations ²
A	Clearance above grade, veranda, porch, deck, or balcony	12" (305 mm)	12" (305 mm)
B	Clearance to window or door that may be opened	12" (305 mm)	9" (229 mm)
C	Clearance to permanently closed window*	*	*
D	Vertical clearance to ventilated soffit	*	*
E	Clearance to unventilated soffit	24" (609.6 mm)‡ 14" (355.6 mm) when using 999-DV-VSD	24" (609.6 mm)‡ 14" (355.6 mm) when using 999-DV-VSD
F	Clearance to outside corner	0" (0 mm)	0" (0 mm)
G	Clearance to inside corner	4" (101.6 mm)	4" (101.6 mm)
H	Clearance to each side of center line extended above meter / regulator	3' (914 mm) within a height 15' (4.57 m) above the meter / regulator assembly	*
I	Gas service regulator vent outlet	3' (914 mm)	*
J	Clearance to non-mechanical air supply inlet to building or the combustion air inlet to any other appliance	12" (305 mm)	9" (229 mm)
K	Clearance to mechanical air supply inlet	6' (1.83 m)	3' (914 mm) above if within 10' (3.05 mm)
L	Clearance above paved sidewalk or driveway located on public property.	7' (2.13 m) †	*
M	Clearance under veranda, porch, deck, or balcony.	12" (305 mm) ‡	*
N	Minimum clearance from roof to lowest discharge opening.	18" (457 mm)	18" (457 mm)
O	Clearance from vertical vent to adjacent wall.	24" (610 mm)	24" (610 mm)

Notes:

1) In accordance with the current CSA B149.1, Natural Gas and Propane Installation Code.

2) In accordance with the current ANSI Z223.1/NFPA 54, Natural Fuel Gas Code.

• Recommended to prevent condensation on the window.

* For clearances not specified and ANSI Z223.1/NFPA 54 or CSA B149.1, clearance must be in accordance with local installation codes and the requirements of the gas supplier.

† A vent shall not terminate directly above a sidewalk or paved driveway that is located between two single family dwellings and serves both dwellings.

‡ Permitted only if veranda, porch, deck, or balcony is fully open on a minimum of two sides beneath the floor.

‡ Clearance to unventilated soffit (E) may be reduced to 14" (355.6 mm) by adding a shield (part number: 999-DV-VSD) to the Duravent termination (see Figure 10.6.03)

WARNING

A safety cage may be required to cover a horizontal termination if the termination is located near a walkway. See local codes.



Figure 10.6.03:

10.7 Snorkel Termination Installation

- Follow snorkel termination manufacturer's installation instructions and local codes
- The vertical rise of a snorkel termination can be used in place of a vertical vent rise. Follow the snorkel termination manufacturer's information for installation.
- A snorkel counts as two 90° elbows out of the total number of allowable elbows in the vent run. For example, the installation in **Figure 10.7.01** shows the use of 3 90° elbows.
- Ensure there is enough vertical venting to accommodate the number of elbows used. Refer to **Section 10.1** or **Section 10.2**.
- If the snorkel termination is installed below grade, (IE: basement) proper drainage must be provided to prevent water from entering the snorkel termination (see **Figure 10.7.01**).
- Do not attempt to enclose the snorkel termination in the wall or any other type of enclosure.
- Do not locate snorkel termination where excessive snow or ice build up may occur. Check snorkel termination area after every snow fall and clear if necessary to prevent blockage. If using snow blowers, make sure snow is not directed at the snorkel termination.

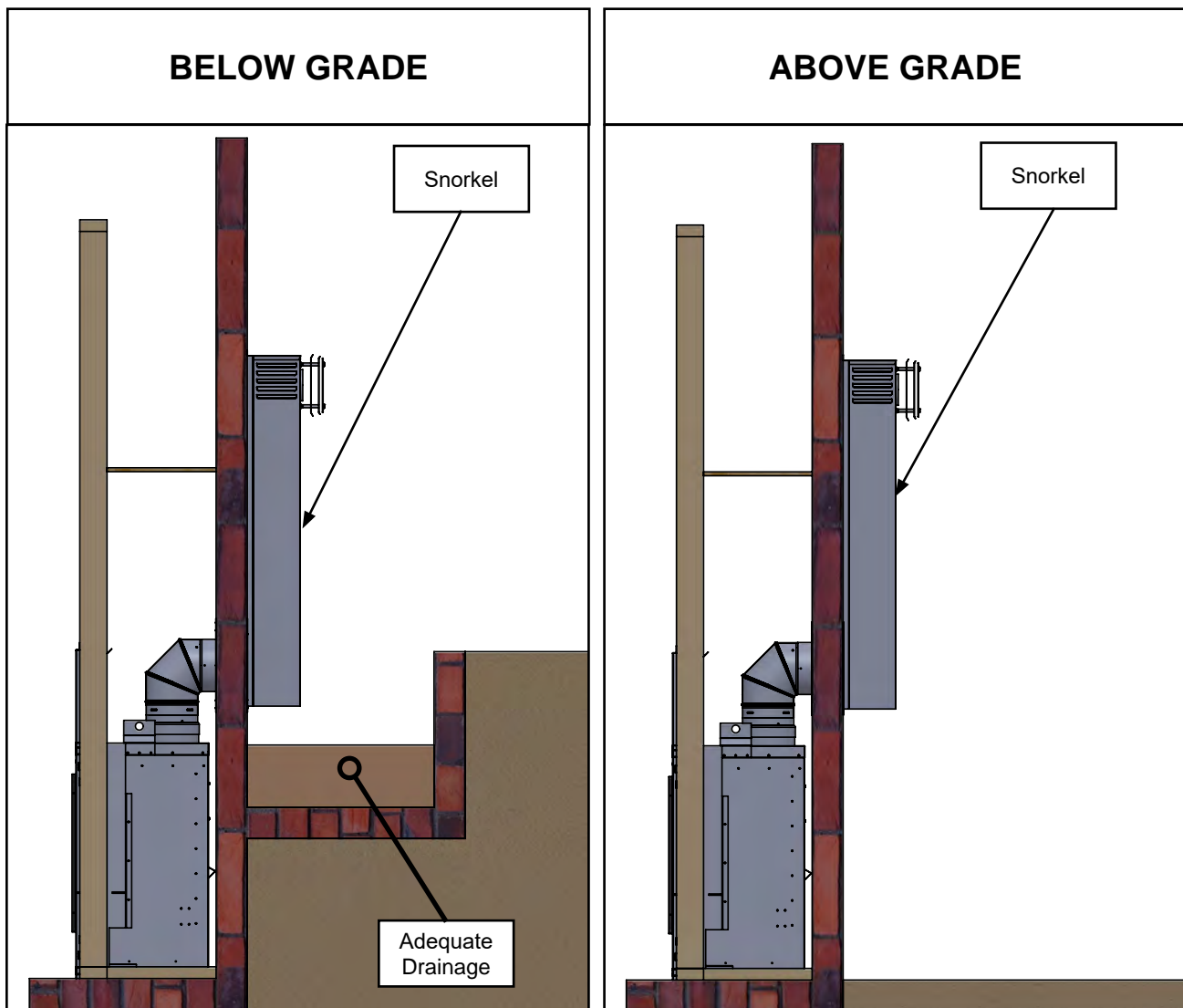

Figure 10.7.01

Installation

11.0 Framing

11.1 Wall Enclosure Rough Opening

IMPORTANT

Framing dimensions should allow for wall covering thickness and fireplace facing materials. If using a hearth and a decorative front, adjust rough opening size as necessary to maintain at least minimum clearance requirements.

Non-combustible facing material may be applied over (but not directly to) fireplace face. This will prevent facing material from falling off due to heat expansion. Do not obstruct the flow of ventilation air.

WARNING

Provide adequate clearances around air openings into the combustion chamber. Do not obstruct upper and lower grill openings. Room air enters through lower passage, is heated and exits through upper passage. Blocking these passages may result in overheating, creating a potentially hazardous situation.

Determine exact position of your fireplace, including hearth height, width, and depth (if applicable). If possible, place fireplace in such a manner that vent termination will be between two studs, eliminating the need for additional framing.

Consider height of hearth finish material (stone, brick etc.) when building fireplace platform to ensure it doesn't impact with the finishing strips or decorative front.

Install fireplace on hard metal or wood surface extending the full width and depth of fireplace.

If masonry is to be used (optional), prepare the necessary foundation for the masonry load. When masonry construction is used, a lintel iron must be used over top of fireplace to support the added weight. Never use this fireplace to support additional weight.

Build optional hearth to desired size and height. If a hearth extension is desired, combustible material may be used. See **Section 12.3**.

IMPORTANT

If installing IHEAT, see the IHEAT manual for framing dimensions and specifications.

FIRE HAZARD

DO NOT install directly on carpet, vinyl, or any combustible material other than wood.

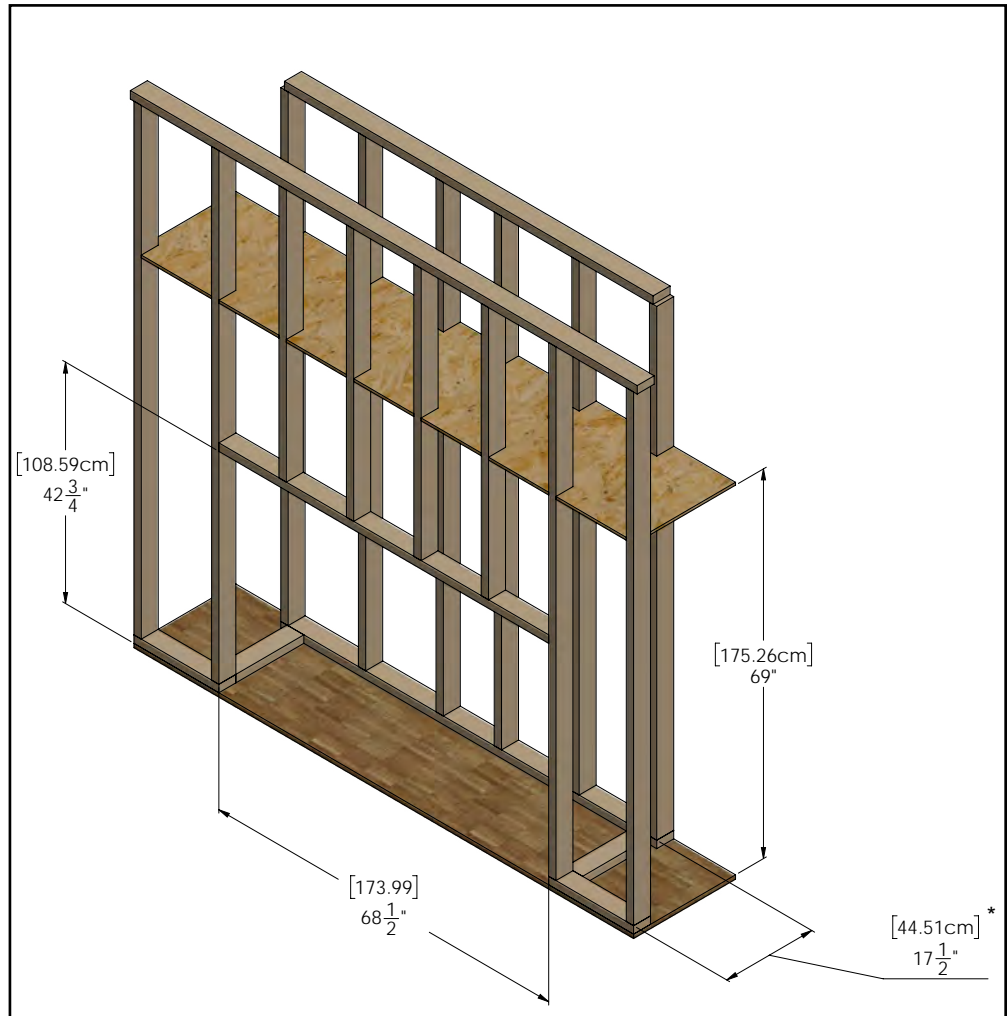

Figure 11.1.01

Wall Board Thickness (Nailing Flange Setting)	*Framing Depth
Flush Install	18"
3/8"	17 ⁵ / ₈ "
1/2"	17 ¹ / ₂ "
5/8"	17 ³ / ₈ "
3/4"	17 ¹ / ₄ "

Installation

11.2 Ventilation Framing, 5" x 8"

IMPORTANT

If installing IHEAT, see the IHEAT manual for framing dimensions and specifications.

Duravent ventilation framing (see Section 10.4 or Section 10.5 for part numbers)

The following ventilation framing dimensions are based on Duravent venting components. If other third party venting components are used, refer to the installation instructions from the third party manufacturer for installation information. The following critical dimensions must be maintained regardless of venting manufacturer:

5" x 8" Dimensions	
Item	Critical Dimensions
Distance from ceiling to horizontal pipe	4" (10.16 cm)
Thimble framing dimensions	10.5" (26.67 cm) W x 10.5" (26.67 cm) H

4" x 6 5/8" Dimensions:

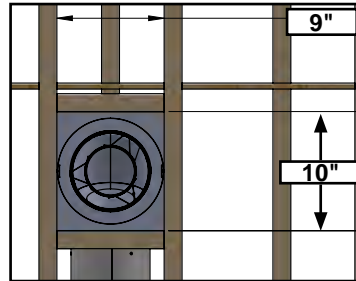

Figure 11.2.01

Ceiling height and the height to the bottom of the thimble shown are based on a minimum vent run. These values may vary depending on the requirements of each installation.

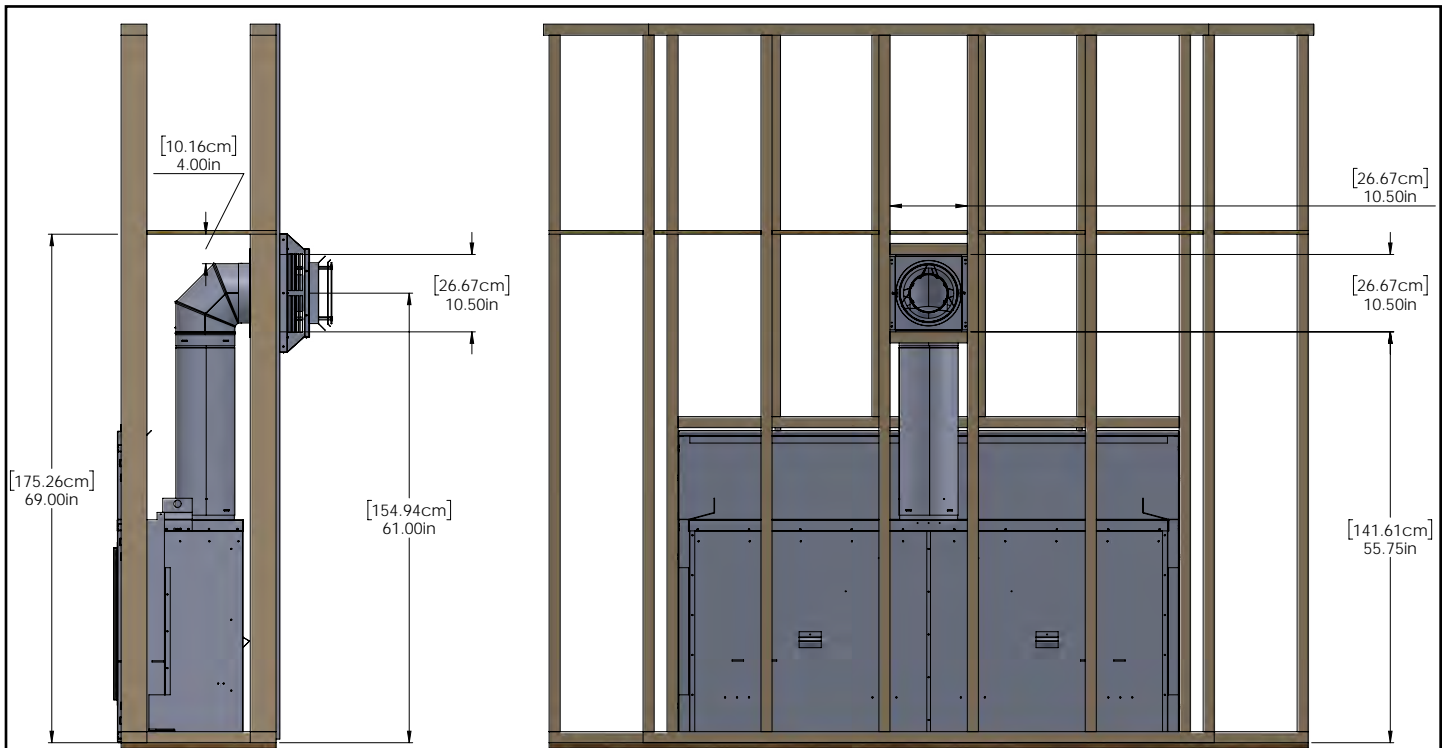

Figure 11.2.02

IMPORTANT

Vent cap location must be in compliance with guidelines in Section 10.6 of this manual.

WARNING

DO NOT RECESS VENT CAP INTO WALL OR SIDING.

12.0 Clearances to Combustibles

IMPORTANT

If installing IHEAT, see the IHEAT manual for framing dimensions and specifications.

WARNING: Failure to position the parts in accordance with these diagrams or failure to use only parts specifically approved with this appliance may result in property damage or personal injury or loss of life.

WARNING: TOP NAILING FLANGE EXTENSION MUST BE ASSEMBLED AND ATTACHED TO FIREPLACE. DO NOT REMOVE. TOP NAILING FLANGE EXTENSION IS NOT LOAD BEARING

12.1 Mantel Clearances

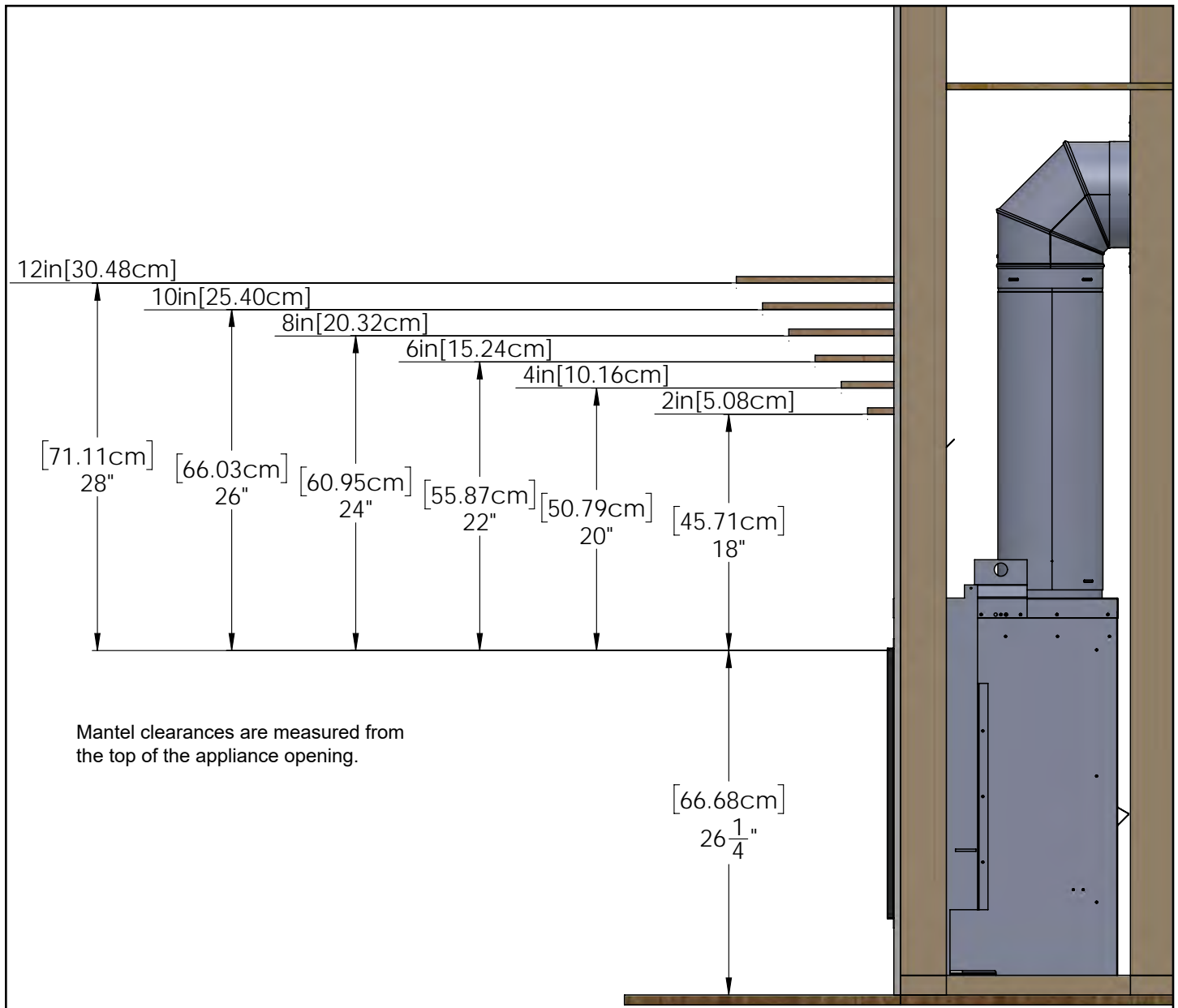

Figure 12.1.01

Installation

12.2 Sidewall Clearances

Maintain a minimum of **3" (7.62 cm)** clearance from the side of the glass door to sidewalls or mantel supports.

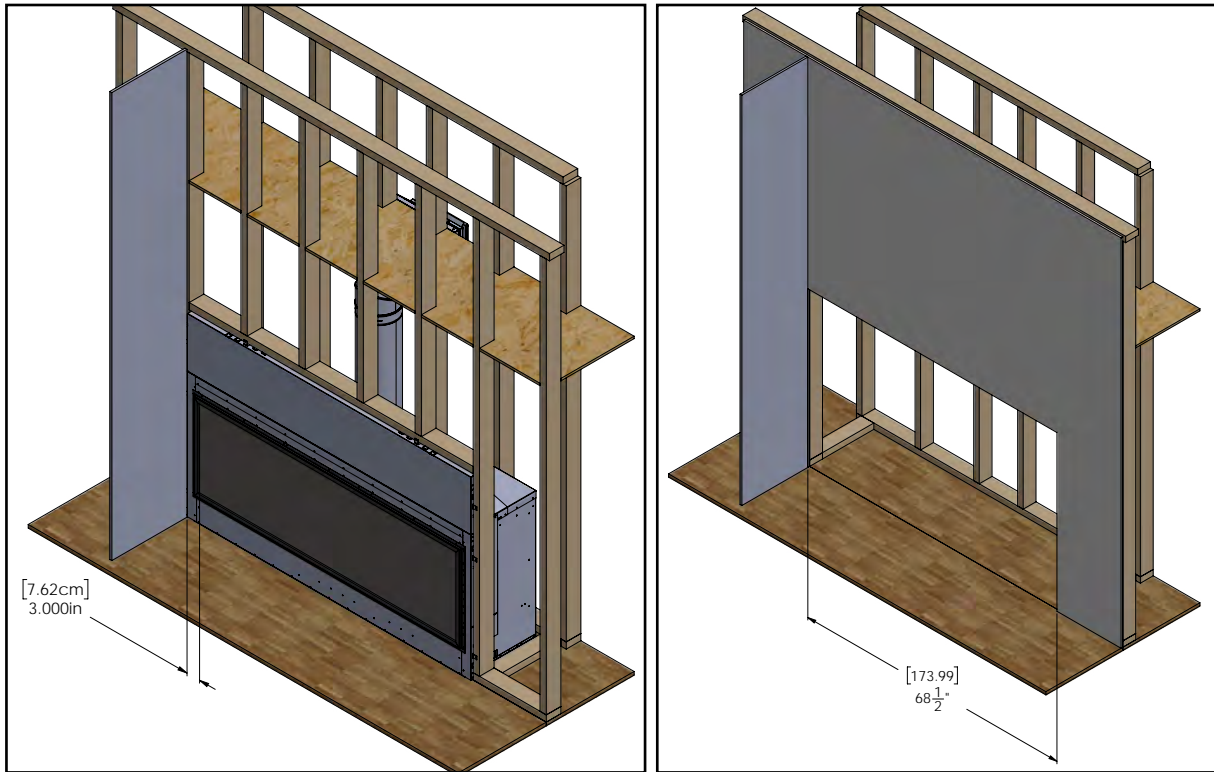

Figure 12.2.01

12.3 Optional Hearth Installation

Any hearth extending from the front fireplace may be constructed of combustible material, however, consideration must be made if installing a decorative front. A hearth is not required for installation.

Clearance to 62-BS Barrier Screen

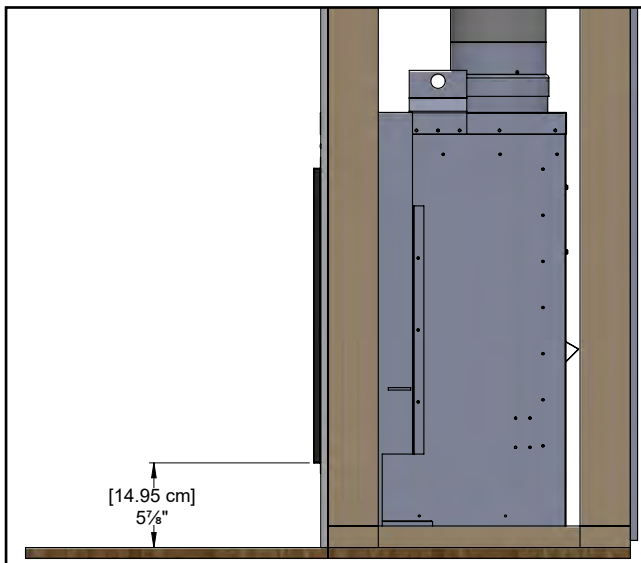

Figure 12.3.01: Clearance to Barrier Screen

Clearance to 62-FSGPB Decorative Front

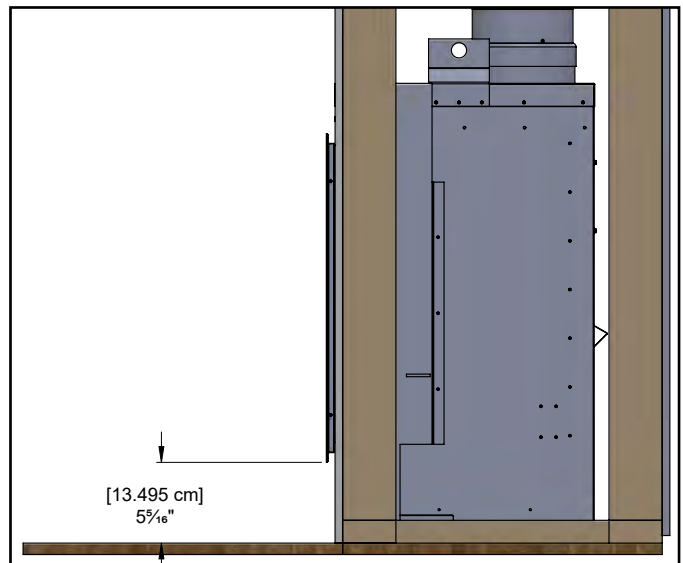

Figure 12.3.02: Clearance to Grandview Park Decorative Fronts

Installation

Archgard fireplaces are heating products, designed to produce a large amount of radiant and convective heat. The clearances specified above are intended to be minimum clearance distances to combustible materials, however, flooring directly adjacent to the minimum hearth clearances may reach temperatures of up to 180°F (82°C) or higher depending on the installation.

Please check with your flooring manufacturer for temperature tolerances as some materials, such as vinyl, tend to be more sensitive to temperatures above average room temperature and may be damaged or warped if exposed to heat.

We recommend testing any flooring material to ensure that it can withstand temperatures generated by this fireplace. If the tolerances of the flooring material are not known or are not capable of withstanding the temperatures generated by this fireplace, install a heat pad constructed of material that is not sensitive to heat, or adjust clearances to heat sensitive materials as shown below.

Note: clearances shown are the width of the fireplace door. The dimensions shown are guidelines only and cannot account for all flooring material. The dimensions shown do not replace the hearth clearances for this product. Always maintain the clearances to combustible materials as shown on the previous page.

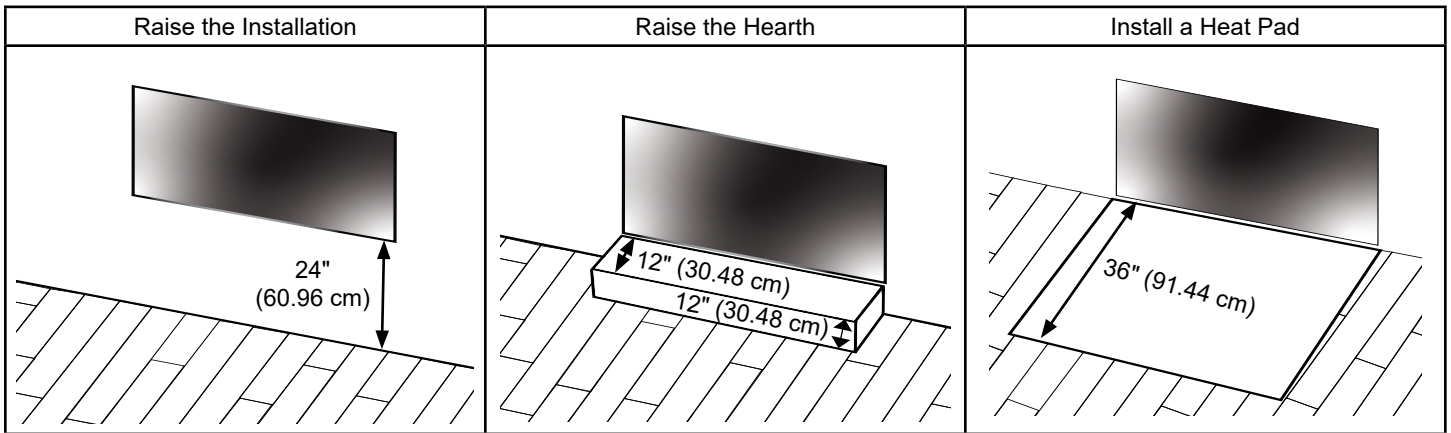

Figure 12.3.03

12.4 Finishing

Install the side strips along with the top and bottom strips using the twenty four (24) 1/8" rivets included.

WARNING: DO NOT PLACE COMBUSTIBLE MATERIAL OVER THE FACE OF THE FIREPLACE UNLESS IHEAT IS INSTALLED.

See the IHEAT manual for further information.

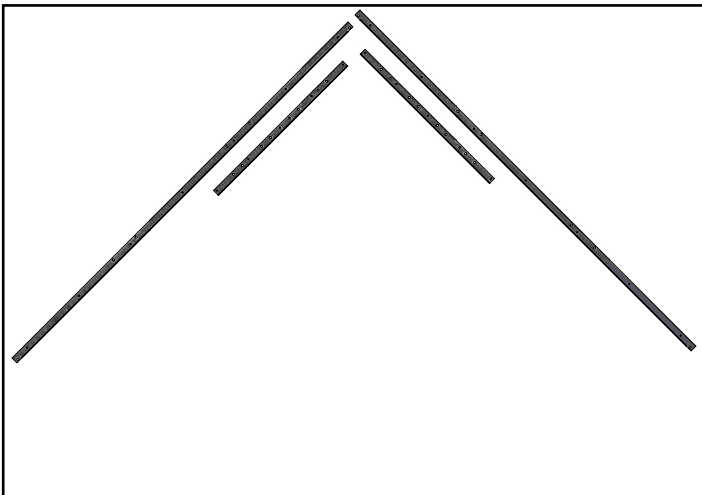

Figure 12.4.01

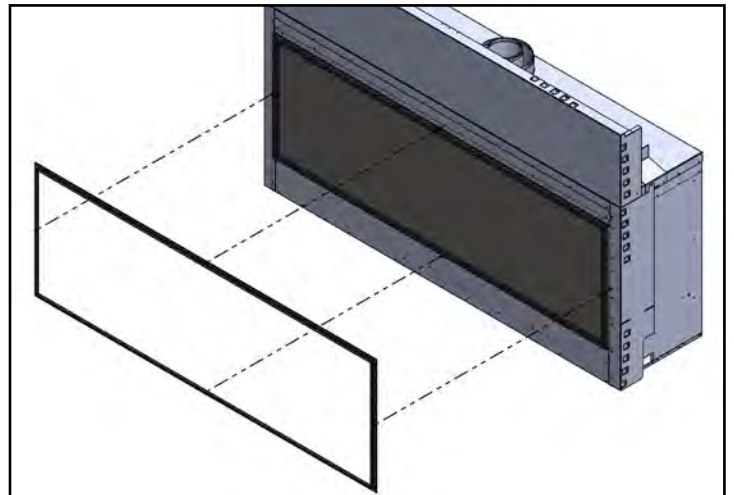

Figure 12.4.02

Installation

Drywall flush with non-combustible material over front

If using a finishing material such as tile, rock, or other non-combustible material to bridge the facing of the fireplace and the wall, install the fireplace flush with the drywall. The finishing strips will extrude by 1/2".

Finish over the front of the fireplace and drywall as shown in **Figure 12.4.04**.

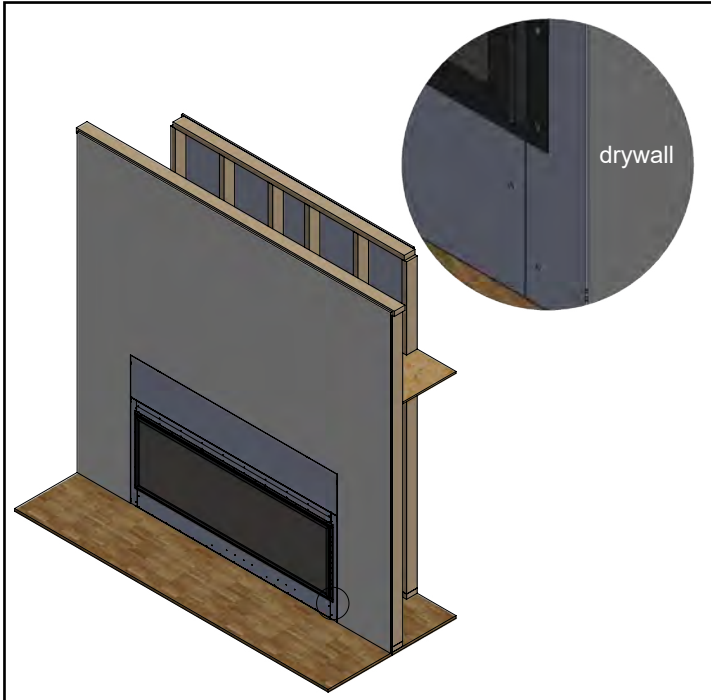

Figure 12.4.03: Drywall flush with fireplace

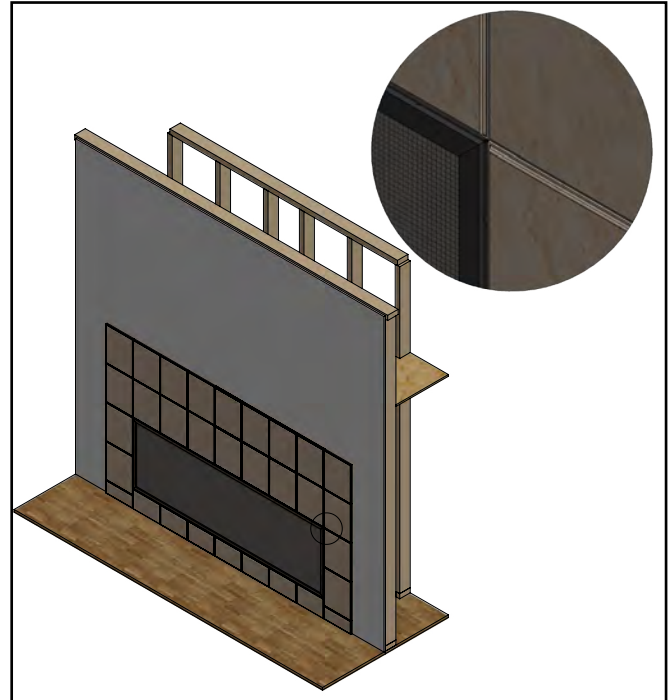

Figure 12.4.04: Tile over face of fireplace and drywall

Recessed installation with non-combustible material flush to drywall

The fireplace may be recessed and finished with cement board or other non-combustible material over the front. Paint the non-combustible material to give the appearance of drywall up to the fireplace opening.

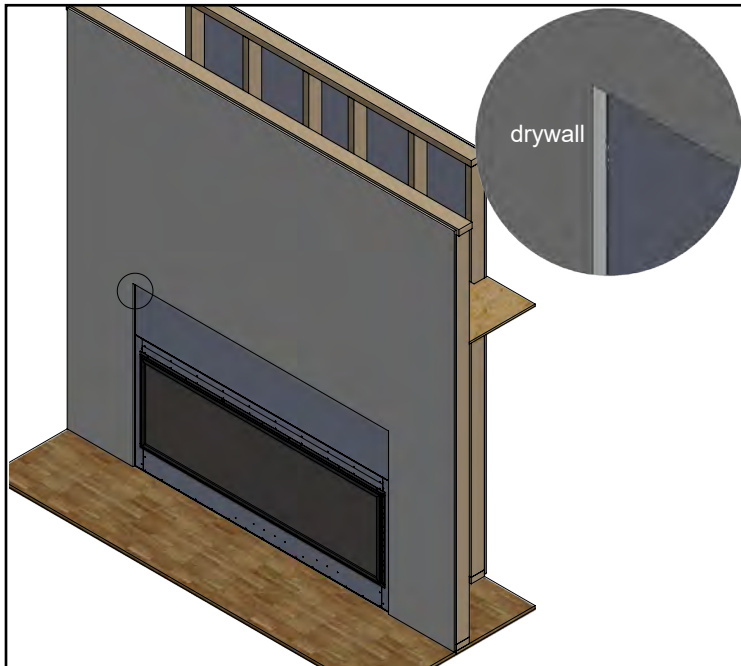

Figure 12.4.05: Drywall to Fireplace (not flush)

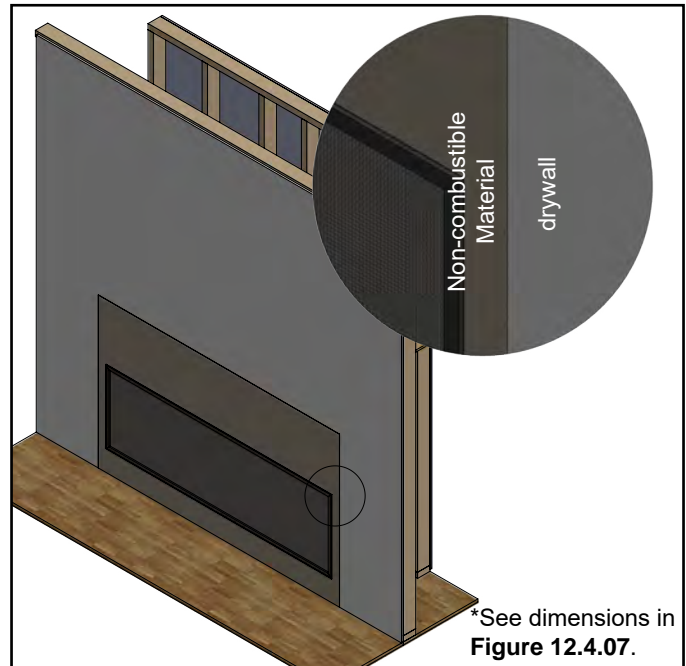

Figure 12.4.06: Non-combustible material over face of fireplace

*See dimensions in **Figure 12.4.07**.

Installation

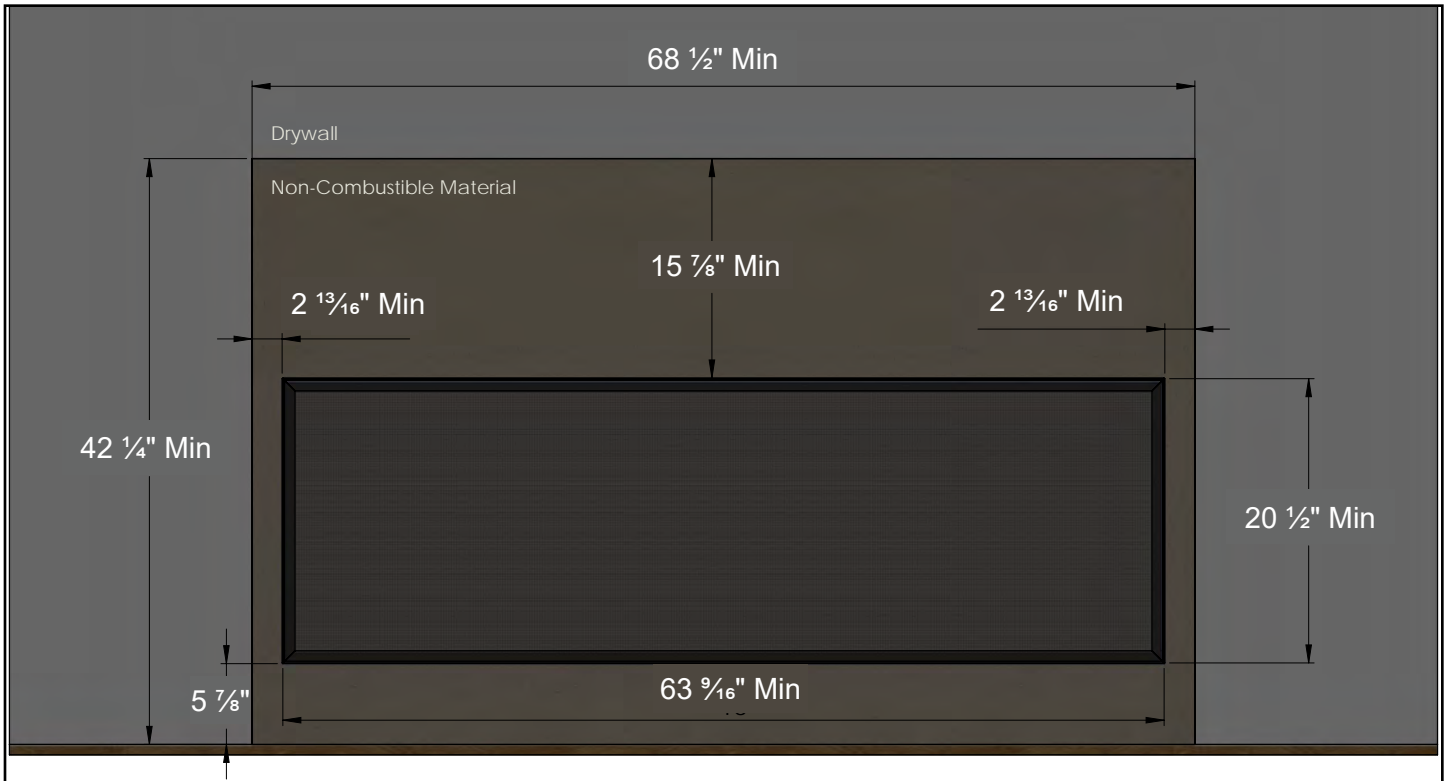

Figure 12.4.07: Dimensions of non-combustible material over face of fireplace

12.5 Installation of Grandview Park Decorative Front

The Archgard Grandview Park decorative front allow you to customize the look of your **62-DVTE46CN-1** to complete your home. See **Section 12.3** for clearance specifications if installing a hearth. Photos and videos may be found on Archgard.com. Please report any damage immediately to your Authorized Archgard Dealer.

Removal

To remove the front, gently lift slightly up and pull the front straight out. The screen is held in place with notched brackets, allowing the screen depth to be adjusted to accommodate the finish material.

Installation

To install the front, align the front with the fireplace opening and push straight in. Gently lift slightly up and slowly push the screen in until it is at the desired depth.



Figure 12.5.01

Grandview Park Dimensions

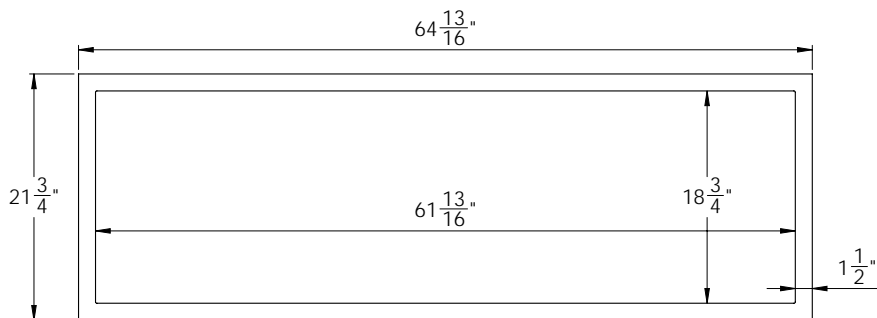

Figure 12.5.02

Installation

13.0 Gas Connections

Before connecting the appliance to the gas supply line, double check that the appliance you have purchased is designed for the gas type you are using. The gas type markings are located on the rating plate (See **Section 4.0** and **Section 6.2**) and also on the appliance's gas valve.

Adequate clearance for proper installation and checking of the gas connections must be provided. **All gas connections must be checked for gas leaks.**

After securing the fireplace to the framing, have your gas supplier or a qualified gas fitter run a gas supply line to the install location. The line must be properly sized and fitted according to the installation codes. Immediately upstream of the supply connection, the fitter shall provide an accessible manual shut-off valve. When connecting the supply line to the gas valve, the installer shall brace the gas valve to ensure that the gas valve is not moved from its bracket. If the valve is not braced when the supply line is connected, the valve may be moved and cause a "break" in the main burner supply line. Such damage is not covered by the manufacturer's warranty.

CAUTION: The appliance and its individual shut-off valve must be disconnected from the gas supply piping system during any pressure-testing of that system at test pressures in excess of 1/2 psig (3.5 kPa). The appliance must be isolated from the gas supply piping system by closing its individual manual shut-off valve during any pressure-testing of the gas supply piping system at test pressures equal to or less than 1/2 psig (3.5 kPa). Failure to do so will damage the appliance's gas valve. Such damage is not covered by the manufacturer's warranty.

Natural Gas Pressure Settings:

The inlet supply or line pressure must be a minimum of 1.1" W.C. (0.27 kPa) and a maximum of 3.8" W.C. (0.95 kPa). The orifices are 2 x #42 DMS (2.4 mm) drill size.

<u>ELEVATION</u>	<u>INPUT RATING</u>
0-4500 ft (0-1372 M)	46,500 BTU/hr (13.63 kW)
4500 ft (1372 M) and above.	46,500 BTU/hr (13.63 kW) less 4% per 1000 ft. (305 M) above sea level.

Please contact your local distributor for the appropriate orifice size you require.

Propane Pressure Settings:

The inlet supply or line pressure must be a minimum of 2.9" W.C. (0.72 kPa) and a maximum of 11.0" W.C. (2.74 kPa). The orifices are 2 x #53 DMS (1.5 mm) drill size.

<u>ELEVATION</u>	<u>INPUT RATING</u>
0-4500 ft. (0-1372 M)	46,500 BTU/hr (13.63 kW)
4500 ft. (1372 M) and above.	46,500 BTU/hr (13.63 kW) less 4% per 1000 ft. (305 M) above sea level.

Please contact your local distributor for the appropriate orifice size you require.

13.1 Clocking Procedure (for high altitude derating)

IMPORTANT: THE INPUT RATING SHOULD ALWAYS BE CHECKED WHEN FIRST FIRING THIS APPLIANCE.

Before you begin, shut off all other gas appliances including any standing pilots. Light the fireplace and wait 15 minutes. Clock the time to burn 1ft³ of gas on the meter. Check with your gas supplier for the gas BTU content at your elevation. Input is the rate of flow multiplied by the heating value of the gas (cubic feet/hour x BTU per cubic feet). **Note:** This assumes a dry gas meter at 1/2 psi. If using a 2 psi dry gas meter the unit will rate lower as the calculation has to correct for the higher pressure in the meter. If the unit is over-rated, contact your authorized Archgard dealer. The following calculation equation gives a rough estimation as it does not correct for temperature and pressure.

Rough Calculation Equation:

$$\frac{3600}{\text{time to burn 1ft}^3 \text{ gas in seconds}} \times \frac{\text{gas caloric value in BTU/ft}^3}{\text{in BTU/ft}^3} = \text{Rating in } \frac{\text{BTU}}{\text{hr}}$$

Installation

13.2 Supplying Gas

Before you begin:

- **Disconnect power supply to the fireplace (including backup batteries)**
- Remove the barrier screen (see **Section 6.3**)
- Remove the glass door assembly (optional - see **Section 6.4**)
- Remove the valve blind (see **Section 6.5**)

NOTE: The gas line can be brought in from either the left or the right side of the fireplace. The connection of the supply line to the valve is made on the left side of the valve.

Step 01: Locate the flex line and shut-off valve in the manual bag.



Figure 13.2.01:

Step 02: Connect the flex line to the inlet side of the valve using two 3/4" wrenches.



Figure 13.2.02:

Step 03: Ensure the shut-off valve is in the OFF and connect gas supply to the shut-off valve.

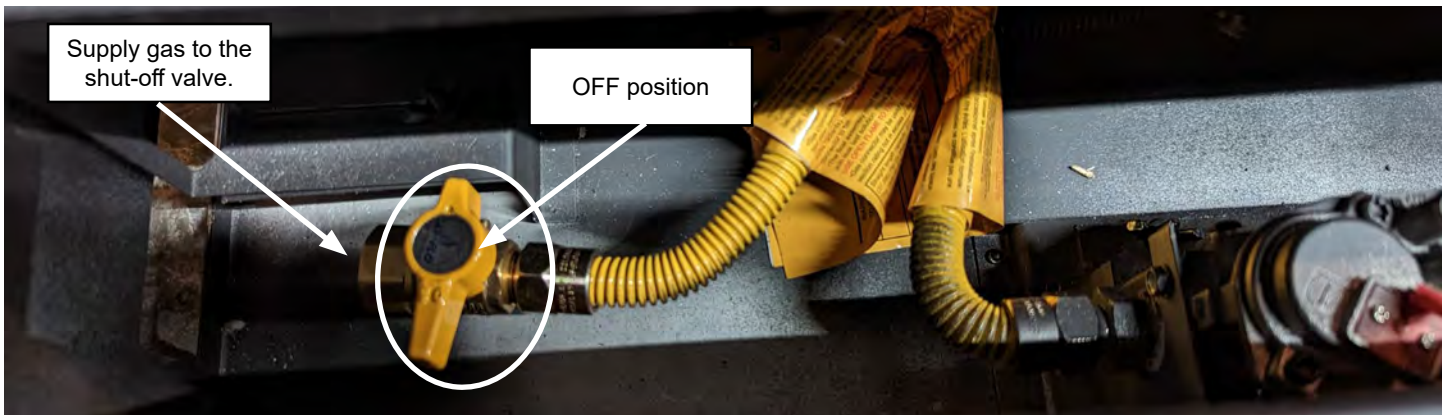

Figure 13.2.03:

Installation

14.0 Conversion Kit Instructions

IMPORTANT: This fireplace is Natural gas ready. If converting to LP gas, follow instructions below.

WARNING: This conversion kit shall be installed by a qualified service agency in accordance with the manufacturers instructions and all applicable codes and requirements of the authority having jurisdiction. If the information in these instructions is not followed exactly, a fire, explosion or productions of carbon monoxide may result, causing property damage, personal injury or loss of life. The qualified service agency is responsible for proper installation of this kit. The installation is not proper and complete until operation of the converted appliance is checked as specified in the instructions supplied with the kit. Refer to appliance owner's manual or product data plate for proper inlet and manifold pressure adjustments and orifice sizing.

IMPORTANT: For high altitude installations above 4500 ft (1372 meters), consult local gas distributor or the authority having jurisdiction for proper derating methods.

KIT NUMBERS: 62-CKELP for LP gas and 62-CKENG for Natural Gas

KIT INCLUDES:

- Gas conversion label (303-0128)
- Burner orifices (part number 2 x 301-0068-53, #53 DMS for LPG) (part number 2 x 301-0068-42, #42 DMS for NG)
- Instruction Sheet
- SIT 885 Valve conversion kit c/w instructions & gas type label

**WARNING: SHUT OFF GAS SUPPLY AND ELECTRICAL POWER TO FIREPLACE
SHUT OFF GAS SUPPLY BEFORE DISCONNECTING ELECTRICAL POWER**

14.1 Prepare the Fireplace

- Remove the barrier screen (see **Section 6.3**), glass door (see **Section 6.4**), burner media (see the media installation manual), valve blind (see **Section 6.5**), and brick panels or firebox liner (see **Section 15.0**)
- Remove the burner surround (see **Section 18.13**)
- Remove the burner (see **Section 18.14**)

Slide the air shutter away from the orifice.

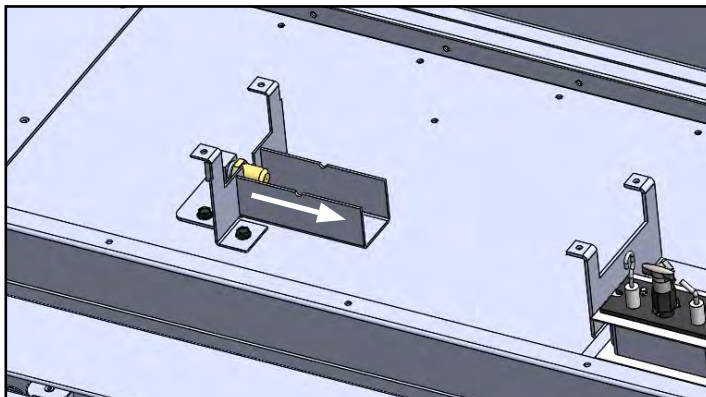

Figure 14.1.01:

Lift the air shutter up and out of the firebox.

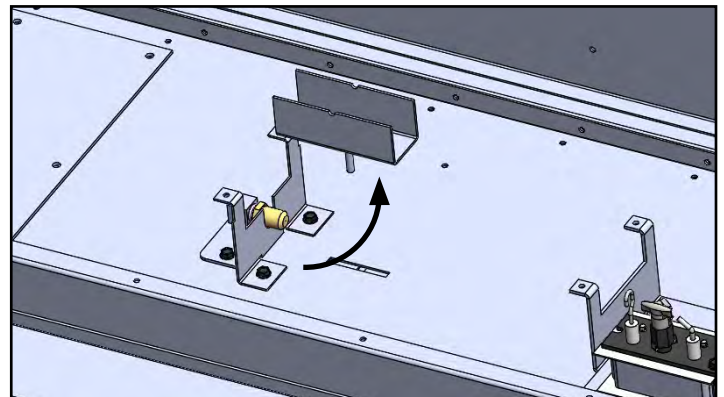

Figure 14.1.02:

Installation

Remove the two (2) tek screws securing the burner support bracket in front of the orifice. Repeat for the other burner.

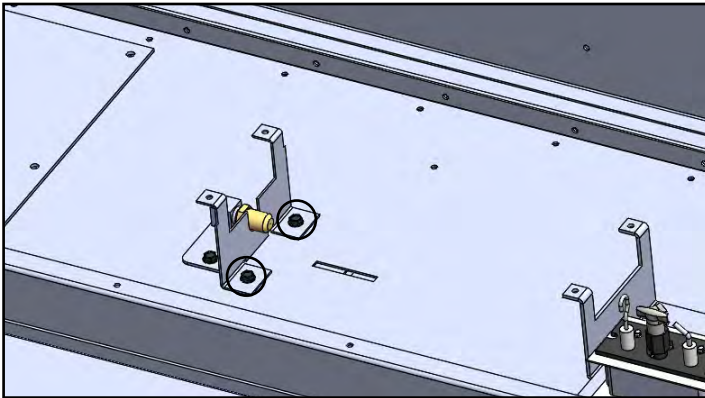

Figure 14.1.03:

Remove the burner orifice using a 1/2" wrench. Replace with the orifice supplied with the conversion kit. Use a small amount of pipe sealant on the threads of the orifice mount. Do not use too much as it can block the orifice.

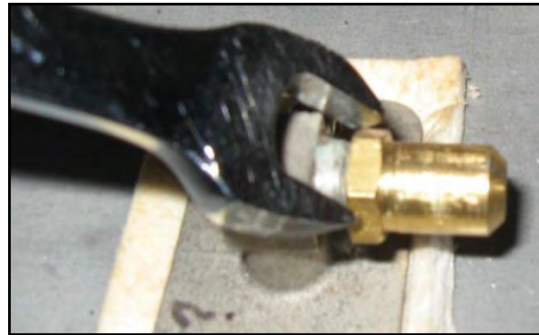

Figure 14.1.04:

14.2 Pilot Conversion

Using a 7/16" wrench and loosen the pilot hood 1/4 turn. Slide the tab at the bottom of the orifice hood all the way so the red side (propane) with the hole in it is showing. Tighten the pilot hood back up so that it is lined up with the two probes on both sides of the pilot assembly.

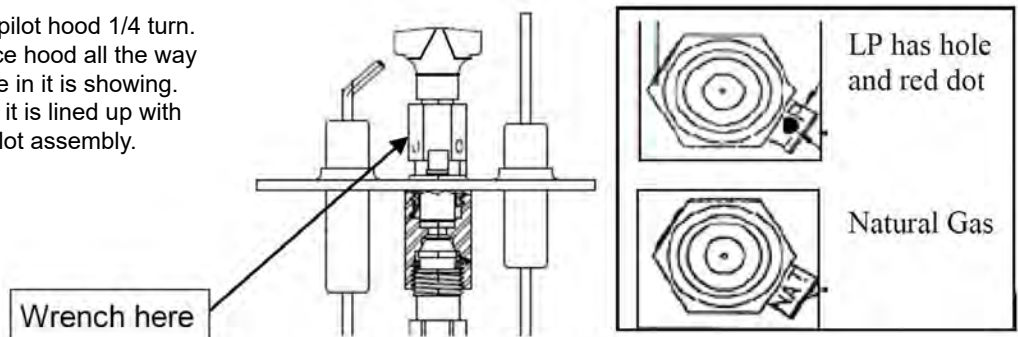

Figure 14.2.05:

Installation

14.3 Convert the Gas Valve

WARNING: Installation of this conversion kit must only be undertaken by a qualified and certified gas appliance installer.

Verify that the following items are present in the package:

- Pressure regulator assembly (E)
- Two (2) screws (F)
- Identification label (G)
- Installation instructions (this document)

1. Shut off the gas supply to the valve and shut down the electric supply.
2. See **Figure 14.3.01**. Using a Torx T20, or slotted screwdriver, remove and discard the two (2) pressure regulator mounting screws (A), pressure regulator tower (B), and the spring and diaphragm assembly (C), (if applicable).
3. Ensure the rubber gasket (D), which is prefitted as part of assembly (E), is properly positioned, see **Figure 14.3.02**, otherwise fit the gasket as shown **Figure 14.3.02**.
4. Install the new STEPPER MOTOR pressure regulator assembly, as shown in **Figure 14.3.03** and **Figure 14.3.04**. Use the supplied screws (F), M4 x 0.7 threaded, length of thread $L = (16 \text{ mm} + 0 - 0.5 \text{ mm})$, steel material, resistance class 8.8 (see **Figure 14.3.05**).
5. Manually thread the two conversion kit mounting screws into the valve body. Use a standard screwdriver or T20 Torx bit and tighten to the screws with a fixing torque of $25 \text{ lb-in} \pm 5\%$.
IN THE EVENT THAT THE THREADS OF THE VALVE ARE STRIPPED OR DAMAGED, REPLACE THE VALVE.
6. Install the enclosed identification label (G) to the valve body where it can be easily seen.
7. Make STEPPER MOTOR and valve electrical connections, apply gas to system and relight appliance according to manufacturers instructions.
8. With the main burner ON, test the new pressure regulator assembly for leaks using a soap solution.
9. Relight the main burner and verify proper burner ignition and operation.

WARNING: Installation should be carried out in a clean environment.

WARNING: This modulating conversion kit must ONLY be applied as part of a conversion kit supplied by the APPLIANCE MANUFACTURER.

WARNING: Correct operation of the system cannot be guaranteed if the conversion kit or valve has been dropped or has sustained a strong impact.

INSTALLER NOTICE: These instructions must be left with appliance.

14.4 Complete the Conversion

- Reinstall the burner (see **Section 18.14**), burner surround (see **Section 18.13**), brick liners or firebox liner (see **Section 15.0**), burner media (see the media installation manual), and glass door (see **Section 6.4**).
- Turn on the gas and electrical supplies
- Turn on the fireplace so the burner is on
- Check for leaks at **all** connections

Test inlet and outlet pressure (See **Section 18.3**). Visually check pilot flame. Flame should envelope top of the flame sensor and extend forward onto the burner. To adjust pilot turn the pilot adjustment screw on the control valve clockwise to decrease or counter clockwise to increase pilot flame. Clock the rating as shown in **Section 13.1**. Adjust the primary air according to specifications in this manual or as found on the rating plate.

- Turn fireplace off
- Affix gas type label to the rating plate label (See **Section 6.2** for rating plate location)
- Complete the conversion label and affix to valve assembly plate
- Reinstall the valve blind (see **Section 6.5**) and barrier screen (see **Section 6.3**)

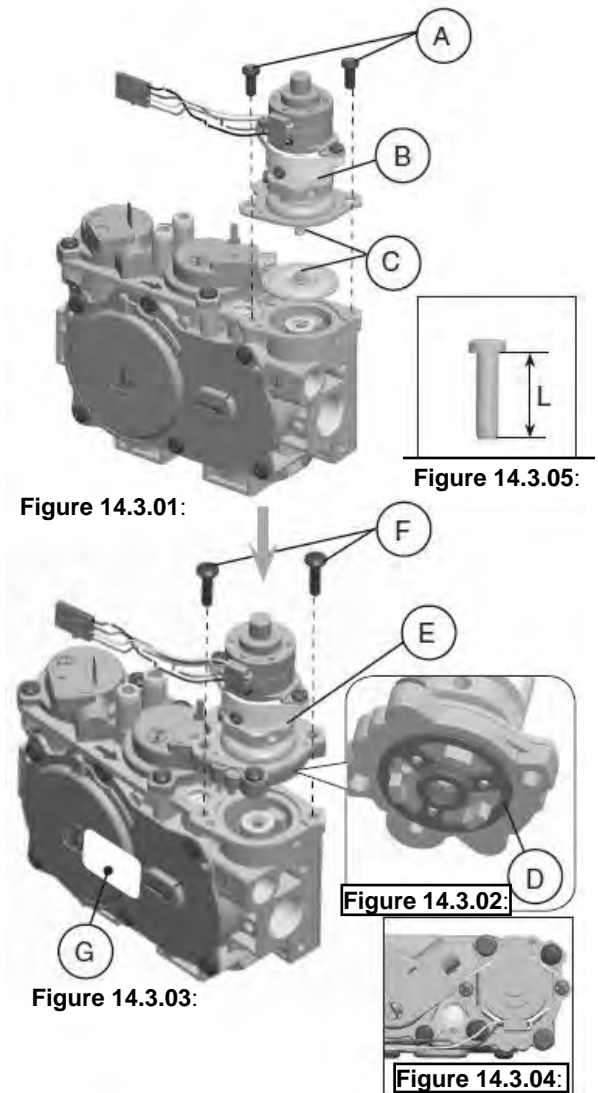

15.0 Firebox Liner Installation

15.1 Midnight Black Panel Installation

The following steps highlight the procedure for installing Midnight Black steel panel firebox liners. Handle the panels with care to avoid scratching the paint. Inspect the panels to ensure that no damage has occurred inside the package. Please report any damage immediately to your Authorized Archgard Dealer.

Before you begin:

- **Ensure the gas supply is turned OFF and disconnect the power supply (including backup batteries)**
- Remove barrier screen (see **Section 6.3**)
- Remove the valve blind (see **Section 6.5**)
- Remove Glass Door (see **Section 6.4**)

Step 02: Attach the fractal panel using 6 x tek screws from the manual bag. Repeat for the other side.



Figure 15.1.02:

Step 04: Rotate the bottom of the panel in and insert two (2) tek screws from the manual bag to secure the middle rear panel in place.



Figure 15.1.04:

Step 01: Align the top left or top right side panel (fractal) with the left or right upper side of the firebox.



Figure 15.1.01:

Step 03: Insert the middle tabs on the top of the middle rear panel into the openings in top of the firebox.

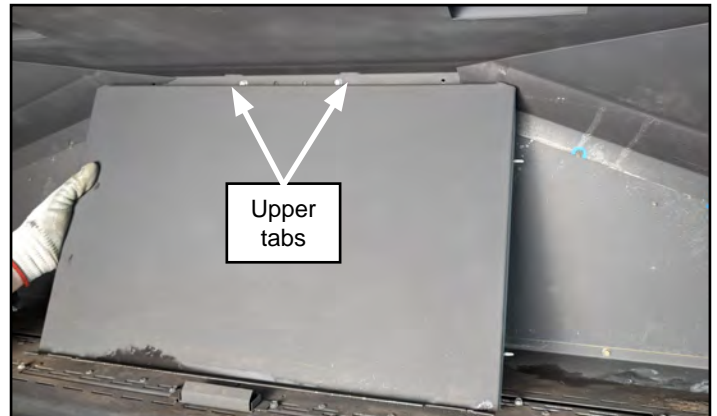

Figure 15.1.03:

Step 05: Align the left or right side rear panel with the screws on the side of the middle rear panel. This manual shows installation from right to left but the opposite may be done.



Figure 15.1.05:

Installation

Step 06: Rotate the side of the panel in and Insert two (2) tek screws from the manual bag to secure the side rear panel in place.



Figure 15.1.06:

Step 07: Place the bottom of the left or right side panel behind the screws on the left side of the burner. Do not place it tight to the side.



Figure 15.1.07:

Step 08: Rotate the left side panel up.



Figure 15.1.08:

Step 09: Insert two (2) tek screws from the manual bag to secure the side panel in place.



Figure 15.1.09:

Step 10: Insert the phillips head screw from the manual bag to secure the top of the panel.



Figure 15.1.10:

Step 11: Repeat **Step 06** through **Step 11** for installation of the right side rear panel and the right side panel.

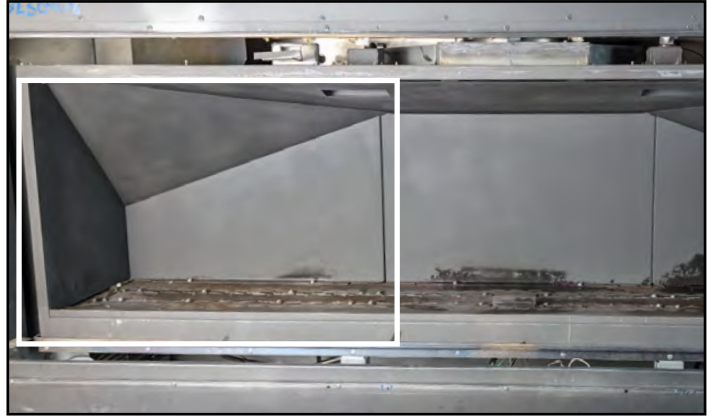

Figure 15.1.11:

Removal is the reverse of installation.

Installation

15.2 Reflective Glass Installation

The following steps highlight the procedure for installing Eternal Flame Reflective Ceramic Glass liner. We recommend using clean cotton gloves when handling panels. Handle the panels with care. Inspect the panels to ensure that no damage has occurred inside the package. Please report any damage immediately to your Authorized Archgard Dealer.

Before you begin:

- Ensure the gas supply is turned OFF and disconnect the power supply (including backup batteries)
- Remove barrier screen (see Section 6.3)
- Remove glass door assembly (see Section 6.4)
- Remove the valve blind (see Section 6.5)

Step 01: Bend the lower tabs on each panel retainer.



Figure 15.2.01:

Step 03: Place the middle rear reflective panel in the middle rear panel retainer.



Figure 15.2.03:

Step 02: The middle panel retainer contains upper and lower tabs.

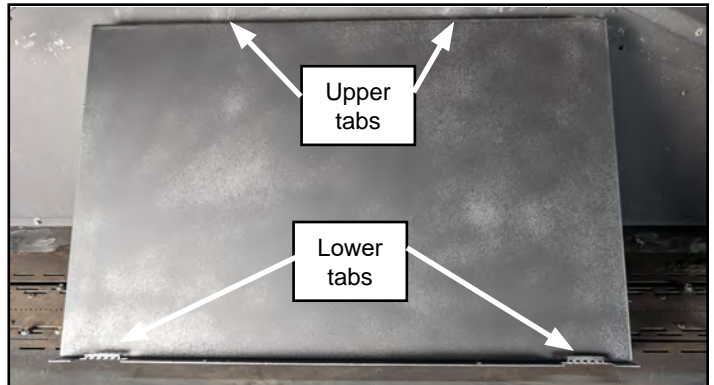

Figure 15.2.02:

Step 04: Place the top side (fractal) panel retainer clips over the upper corners of the rear panel and rear panel retainer.



Figure 15.2.04:

Installation

Step 05: Insert the top tabs on the middle rear panel retainer in the slots in the top of the firebox and rotate the bottom of the rear panel retainer in.

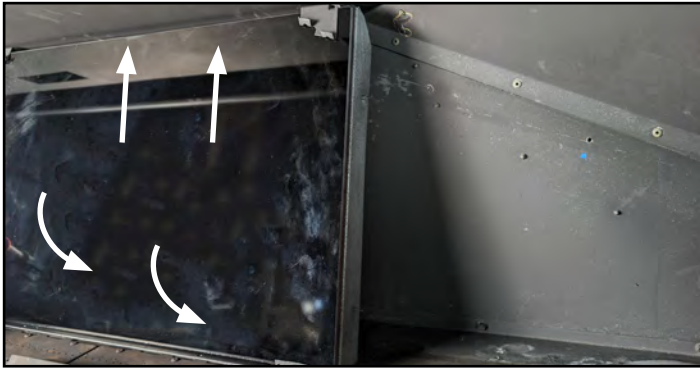

Figure 15.2.05:

Step 06: Insert two (2) tek screws from the manual bag to secure the middle rear panel retainer in place.



Figure 15.2.06:

Step 07: The sides of the middle rear panel retainer contains screws intended to hold the rear side panels in place.



Figure 15.2.07:

Step 08: Slide the right rear side panel retainer into place.



Figure 15.2.08:

Step 09: Insert two (2) tek screws from the manual bag to secure the right rear side panel retainer in place.



Figure 15.2.09:

Step 10: Insert the right rear side panel in the panel retainer.



Figure 15.2.10:

Installation

Step 11: Align the right side panel retainer with the right side of the fireplace. The right side panel retainer will help hold the right side rear panel in place.



Figure 15.2.11:

Step 12: Rotate the top of the right side panel retainer toward the side of the fireplace and insert two (2) tek screws from the manual bag to secure the rear side panel retainer in place.



Figure 15.2.12:

Step 13: Place the right side glass panel in the right side glass panel retainer.



Figure 15.2.13:

Step 14: Use a phillips screw from the manual bag to install the right side clip and right side panel retainer to the top of the firebox.



Figure 15.2.14:

Step 15: Repeat for the left side.



Figure 15.2.15:

Step 16: Align the top right panel (fractal) to rest on top of the right side panel.



Figure 15.2.16:

Installation

Step 17: Slip the right corner of the panel between the two tabs on the clip on the top right corner of the middle rear panel.



Figure 15.2.17:



Figure 15.2.18: Detail view of corner in clip

Step 18: Repeat for the top left panel (fractal).

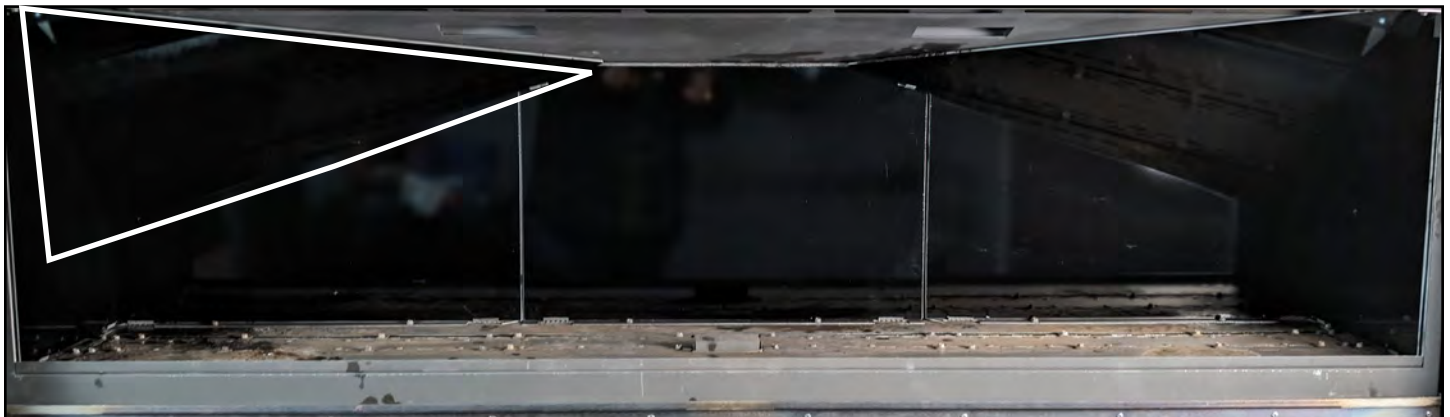

Figure 15.2.19:

Removal is the reverse of installation.

Installation

15.3 Refractory Panel Installation

The following steps highlight the procedure for installing refractory panel firebox liners. Handle the panels with care as they are delicate. Inspect the panels to ensure that no damage has occurred inside the package. Please report any damage immediately to your Authorized Archgard Dealer.

Before you begin:

- **Ensure the gas supply is turned OFF and disconnect the power supply (including backup batteries)**
- Remove barrier screen (see **Section 6.3**)
- Remove glass door assembly (see **Section 6.4**)
- Remove the valve blind (see **Section 6.5**)

Note: The rear panel in the Appalachian Ledgestone Grey is divided into three (3) pieces. The rear panel in the Lost Coast Black panel is divided into two (2) pieces. The method of installation is otherwise the same. The following steps show installation of the Appalachian Ledgestone Grey panel set.



Figure 15.3.01: Appalachian Ledgestone Grey (three pieces)



Figure 15.3.02: Lost Coast Black (two pieces)

Step 01: Place the large rear panel piece in the back of the firebox.



Figure 15.3.03:

Step 02: Place the remaining rear panel pieces.



Figure 15.3.04: Appalachian Ledgestone Grey, 3-piece rear panel



Figure 15.3.05: Lost Coast Black, 2-piece rear panel

Installation

Step 03: Continue to hold the rear panel. Place the left side panel. The left side panel will help hold the side of the rear panel.



Figure 15.3.06:

Step 04: Install the left side panel clip using the phillips screw from the manual bag included with the fireplace.



Figure 15.3.07:

Step 05: Repeat **Step 03** and **Step 04** for the opposite side.



Figure 15.3.08:

Step 06: Take the upper right panel (fractal).

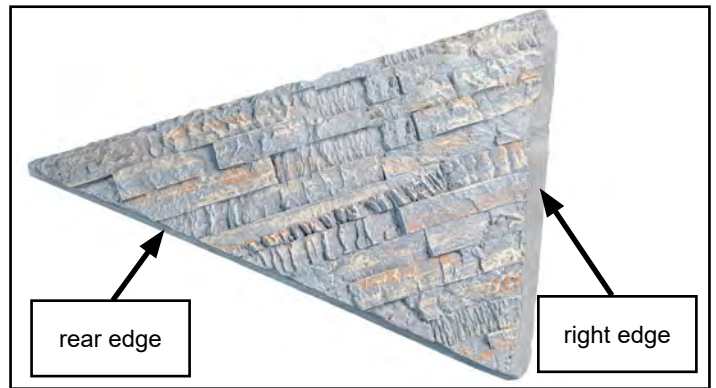

Figure 15.3.09:

Step 07: Align the upper right panel (fractal) between the right side panel and rear panel.



Figure 15.3.010:



Figure 15.3.011:

Installation

Note: The panel should show a clean edge when properly installed.



Figure 15.3.12: Incorrect install



Figure 15.3.13: Correct install

Step 08: Repeat **Step 06** and **Step 07** on the left side to complete installation.



Figure 15.3.14: Appalachian Ledgestone Grey Panel Set



Figure 15.3.15: Lost Coast Black Panel Set

Removal is the reverse of installation.

16.0 Burner Media Installation

The Kōjin Series has more burner media installation options than any other Archgard fireplace. The images below are a small sample of the possibilities Kōjin 62 has to offer. Information on how to install media may be found in the Burner Media installation manual included with the fireplace.



Figure 16.0.01: Clear White Fire Beads



Figure 16.0.02: Clear White Fire Beads with Silhouette Log Set



Figure 16.0.03: Amber Fire Beads



Figure 16.0.04: Jet Black Fire Beads



Figure 16.0.05: Mississippi River Rocks



Figure 16.0.06: Santa Cruz River Rocks



Figure 16.0.07: Grand Timber Set A with Black Embers



Figure 16.0.08: Silver Birch Set A & B with Black Embers

17.0 Operation

17.1 Before Lighting

WARNING: If you do not follow these instructions exactly, a fire or explosion may result causing property damage, personal injury or loss of life. Do not operate the appliance with the glass front removed, cracked or broken. Replacement of broken glass should be done by a licensed or qualified service person.

Each Archgard Gas Fireplace is checked and tested at the factory prior to being packaged and shipped to our dealers and finally installed in your home. Archgard recommends that before leaving this unit with the customer, the installer must ensure that the appliance is firing correctly and that the electrical system is in working order. This will include:

1. Performing leak tests of supply line, gas control valve, supply line from gas control valve and pilot assembly.
2. Clocking the appliance to ensure the correct firing rate (see **Section 13.1** of this manual).
3. If required, adjusting the primary air to burner to ensure that the flame does not carbon or soot.
4. Checking for proper operation including correct drafting.
5. Turning the fireplace ON to ensure that the fan is working correctly. After the system has been checked and confirmed that the fan is in working order, refer to the instructions for FIRST FIRE located in this manual.

Use the installation checklist in **Section 5.0** to ensure all installation steps have been completed.

Note: Any alteration to this product that causes carbon or soot deposits that results in any damage or requires cleaning is not the responsibility of the manufacturer.

Do not store or use gasoline or other flammable vapors and liquids in the vicinity of this or any other appliance.

WHAT TO DO IF YOU SMELL GAS:

- Do not try to light any appliance.
- Do not touch any electrical switch; do not use any phone in your building.
- Immediately call your gas supplier from a neighbor's phone. Follow the gas supplier's instructions.
- If you cannot reach your gas supplier, call the fire department.

Installation and service must be performed by a qualified installer, service agency or the gas supplier.

1. **BEFORE LIGHTING**, smell all around the appliance area for gas. Be sure to smell next to the floor, because some gasses are heavier than air and will settle on the floor.
2. **IF YOU SMELL GAS**, follow the instructions as listed directly above or as shown on the front cover of this manual.
3. Do not use this appliance if any part has been under water. Immediately call a qualified service technician to inspect the appliance and to replace any part of the control system and any gas control which has been under water.
4. This appliance is equipped with an ignition device which automatically lights the pilot and main burner when operating the remote control.

17.2 First Fire

When operated for the first few times, the appliance will emit some odor and fumes. This is due to the heat from the appliance evaporating the oils and solvents used in fabricating the appliance. Close off the room to the rest of the house and open all windows. Keep the room well ventilated, as smoke alarm may sound. Run the appliance for at least 6 hours at maximum setting with blower set to OFF to allow paint to cure (after the installer has checked to ensure the fan is operational). Smoke and fumes caused by the curing process may cause discomfort to some individuals. Clean the glass door after this curing process has completed (see **Section 18.1**). Be sure there are no fingerprints left on the glass panels as high temperatures can bake these prints on permanently.

17.3 Lighting Instructions

The following information may be found on the fireplace rating plate. See **Section 6.2** for the rating plate location.

FOR YOUR SAFETY READ BEFORE LIGHTING
POUR VOTRE SÉCURITÉ VEUILLEZ LIRE AVANT L'ALLUMAGE

WARNING: If you do not follow these instructions exactly, a fire of explosion may result causing property damage, personal injury or loss of life.

AVERTISSEMENT: Quiconque ne respecte pas à la lettre les instructions dans la présente notice risque de déclencher un incendie ou une explosion entraînant des dommages, des blessures ou la mort.

A. This appliance is equipped with an ignition device which automatically lights the pilot. Do not try to light the pilot by hand. When lighting the pilot follow these instructions exactly.

B. BEFORE OPERATING smell all around the appliance area for gas. Be sure to smell next to the floor because some gas is heavier than air and will settle on the floor.

WHAT TO DO IF YOU SMELL GAS

- Do not try to light any appliance.
- Do not touch any electrical switch; do not use any phone in your building.
- Immediately call your gas supplier from a neighbor's phone. Follow the gas supplier's instructions
- If you cannot reach your gas supplier, call the fire department.

C. Do not use this appliance if any part has been under water. Immediately call a qualified service technician to inspect the appliance and to replace any part of the control system and any gas control which has been under water.

A. Cet appareil est équipé d'un dispositif d'allumage qui allume automatiquement la veilleuse. N'essayez pas d'allumer la veilleuse à la main.. Respectez les instructions ci-dessous à la lettre.

B. AVANT D'ALLUMER la veilleuse, renifllez tout autour de l'appareil pour détecter une odeur de gaz. Renifllez près du plancher, car certains gaz sont plus lourds que l'air et peuvent s'accumuler au niveau du sol.

QUE FAIRE SI VOUS SENTEZ UNE ODEUR DE GAZ:

- Ne pas tenter d'allumer d'appareil
- Ne touchez à aucun interrupteur; ne pas vous servir des téléphones se trouvant dans le bâtiment
- Appelez immédiatement votre fournisseur de gaz depuis un voisin. Suivez les instructions du fournisseur.
- Si vous ne pouvez rejoindre le fournisseur, appelez le service des incendies.

C. N'utilisez pas cet appareil s'il a été plongé dans l'eau, même partiellement. Faites inspecter l'appareil par un technicien qualifié et remplacez toute partie du système de contrôle et toute commande qui ont été longés dans l'eau.

LIGHTING INSTRUCTIONS
INSTRUCTION D'ALLUMAGE

1. STOP! Read the safety information above on this label. This appliance is equipped with an ignition device which automatically lights the pilot. Do not try to light the pilot by hand.
2. Set the remote control switch to "OFF".
3. Open the lower louvers, or remove trim and barrier screen.
4. Turn off all electric power to the appliance.
5. Open the gas isolation valve.
6. Wait 5 minutes to clear out any gas. Then smell for gas, including near the floor. If you smell gas, STOP! and follow "B" in the safety information above (and to the left) on this label. If you do not smell gas, go to the next step.
7. Turn on all electric power to the appliance.
8. Set the remote control switch to "ON".
9. If the fireplace does not light, the system will cycle through two trials (one minute of audible clicking, thirty seconds of silence, and then another one minute of audible clicking). If the system locks out due to inadequate gas flow, refer to troubleshooting in instruction manual.
10. If the system will not function correctly, follow the instructions "To turn Off Gas To Appliance" below and call your service technician or gas supplier.
11. Replace louver or trim.

1. ARRÊTEZ! Lisez les instructions de sécurité sur la portion supérieure (à droite) de cette étiquette. Cet appareil est équipé d'un dispositif d'allumage qui allume automatiquement la veilleuse. N'essayez pas d'allumer la veilleuse à la main.
2. Réglez le commutateur à distance sur "OFF".
3. Ouvrez persiennes inférieurs ou garnir.
4. Coupez l'alimentation électrique de l'appareil.
5. Vanne d'isolement de gaz ouverte.
6. Attendez cinq (5) minutes pour laisser échapper tout le gaz. Renifllez tout autour de l'appareil, y compris près du plancher, pour détecter un odeur de gaz. Si vous sentez une odeur de gaz, ARRÊTEZ! Passez à l'étape B des instructions de sécurité sur la portion supérieure (à gauche) de cette étiquette. S'il n'y a pas d'odeur de gaz, passez à l'étape suivante.
7. Réglez le commutateur à distance sur "ON".
8. Allumez l'alimentation électrique de l'appareil.
9. Si le foyer ne se allume pas, le cycle de la volonté du système grâce à deux essais (une minute de clic audible, trente secondes de silence, et puis un autre une minute de clic audible). Si le système se bloque en raison de l'écoulement de gaz insuffisante, voir le dépannage dans le manuel d'instruction.
10. Si le système ne fonctionne pas correctement, suivez les instructions «Pour couper le gaz de l'appareil» ci-dessous et appelez votre technicien d'entretien ou fournisseur de gaz.
11. Persienne fermée ou garnir.

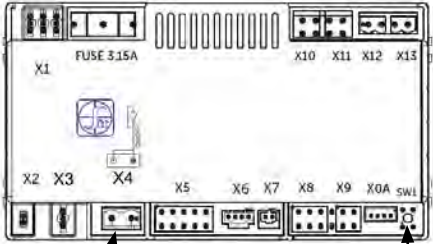

Proflame 885 Board

Remote Override Switch

Remote Sync Button

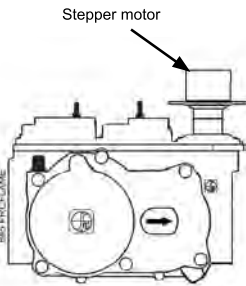

Stepper motor

Proflame 885 Valve

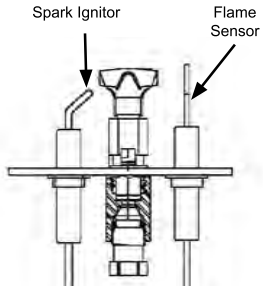

Spark Ignitor

Flame Sensor

Pilot

TO TURN OFF GAS TO APPLIANCE
POUR COUPER LE GAZ À L'APPAREIL

1. Set the remote control switch to "OFF".
2. Turn off all electric power to the appliance if service is to be performed.
3. Open louver or access panel.
4. Turn incoming gas isolation valve to "OFF" position.
5. Close louver or trim.

1. Réglez le commutateur à distance sur "OFF".
2. Coupez l'alimentation électrique de l'appareil s'il faut procéder à l'entretien.
3. Ouvrez persiennes inférieurs ou porte d'accès.
4. vanne d'isolement de gaz à proximité
5. Persienne fermée ou garnir.

Figure 17.3.1:

17.4 Remote Control Operation

IMPORTANT

The Proflame II Remote is an integrated part of the Proflame II System, which consists of a Proflame II Remote, to be used in conjunction with Integrated Fireplace Control (Proflame II Control Module).



Figure 17.4.01

The Proflame II Remote provides for controlling the following hearth appliance functions:

1. Main Burner ON/OFF
2. Main Burner flame modulation (6 levels)
3. Choice of Continuous Pilot on Demand or intermittent pilot (CPI/IPI)
4. Manual, Thermostat, and SMART thermostat functions
5. Comfort fan speed modulation (6 levels)
6. Variable lights (6 levels)

The Proflame II Remote uses a streamline design with a simple button layout and informative LCD display. A Mode Key is provided to index between the features and a Thermostat Key is used for on/off or to index through the thermostat function. Additionally a Key Lock function is provided.

ATTENTION

- TURN OFF THE MAIN GAS SUPPLY DURING INSTALLATION OR MAINTENANCE OF THE RECEIVER DEVICE
- TURN OFF MAIN GAS SUPPLY TO THE APPLIANCE PRIOR TO REMOVING OR REINSERTING THE BATTERIES
- IN CASE OF REMOTE CONTROL MALFUNCTION TURN OFF THE FIREPLACE BY REMOVING POWER SUPPLY (INCLUDING BACKUP BATTERIES)
- FOR INSTALLATION/MAINTENANCE SWITCH OFF THE FIREPLACE BY REMOVING POWER SUPPLY (INCLUDING BACKUP BATTERIES)

Technical Data - Remote Control

Supply Voltage	4.5 V (three (3) 1.5V AAA batteries)
Ambient temperature ratings	0 - 50°C (32 - 122°F)
Radio Frequency	315 MHz

Operation

Remote Display

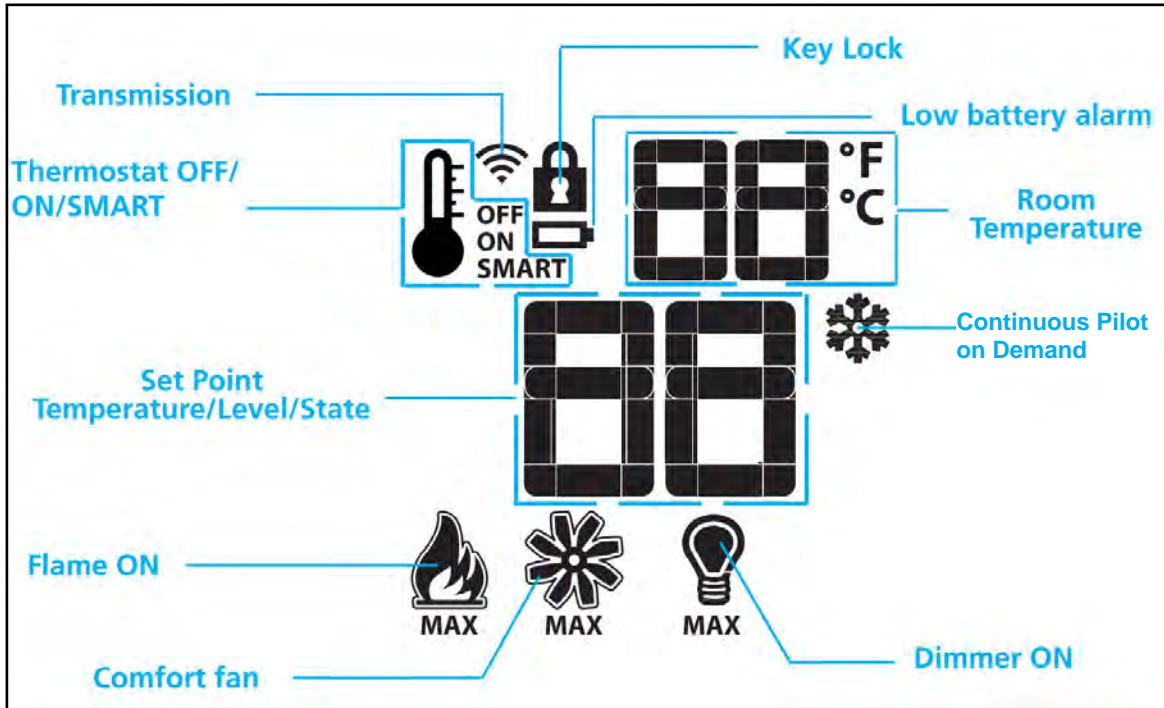

Figure 17.4.02

WARNING

THE REMOTE AND RECEIVER ARE RADIO FREQUENCY DEVICES. PLACING THE REMOTE IN OR NEAR METAL ENCLOSURES MAY REDUCE THE SIGNAL RANGE.

Handheld Remote (optional)



Figure 17.4.03

Operation

Initializing the System for Handheld / Wall Mount Remote Operation

1. Connect IFC Control Module to AC power supply. A single beep will indicate the presence of power. **NOTE: This will initiate Pilot Start-up in Manual Mode. The pilot will spark repeatedly and ignite if gas has been supplied to the unit. Sync the control board to the remote to turn main burner and pilot off using the steps below.**
2. The ON/OFF Override Jumper on the control board must be connected.
3. Press and hold the red SW1 button until the IFC module beeps three (3) times and/or the amber LED illuminates indicating the module is ready to synchronize with the remote.
4. Within ten (10) seconds push the ON/OFF key on the remote. The IFC module will beep four (4) times to indicate that it has successfully synced with the remote. Turn the fireplace OFF using the ON/OFF button on the remote to complete initialization. The remote will now control the fireplace.
5. Install the provided four (4) AA batteries into battery back up holder.

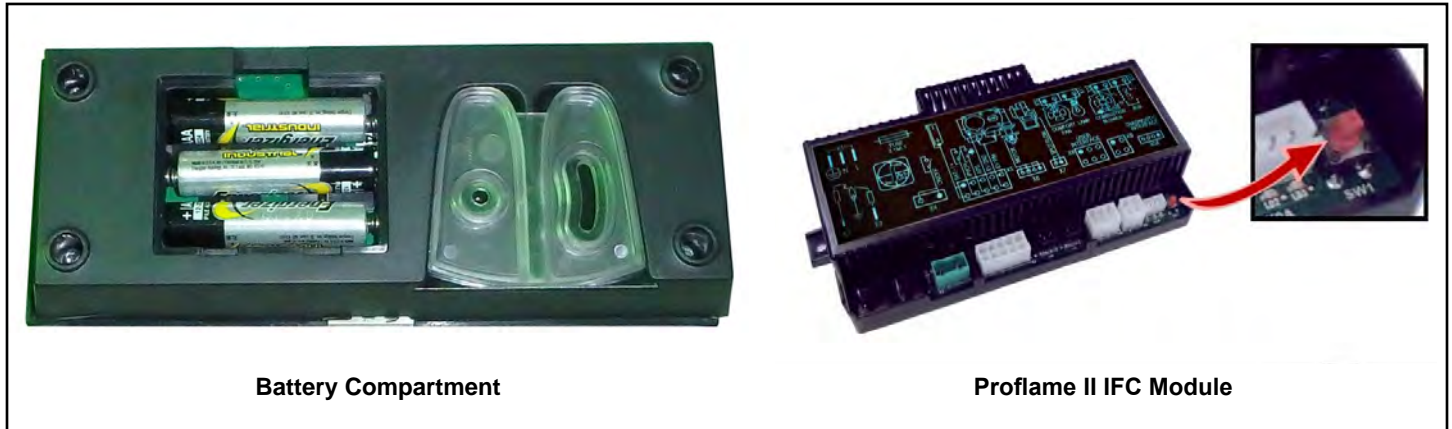

Figure 17.4.04:

Turn ON the Appliance

With the system OFF, press the ON/OFF Key on the Remote. The Remote display will show other active icons on the screen. At the same time the Receiver will activate the appliance. A single beep from the receiver will confirm reception of the command.

Turn OFF the Appliance

With the system ON, press the ON/OFF Key on the Remote. The Remote display will show the current room temperature. At the same time the Receiver will turn the appliance off. A single beep from the receiver will confirm reception of the command.

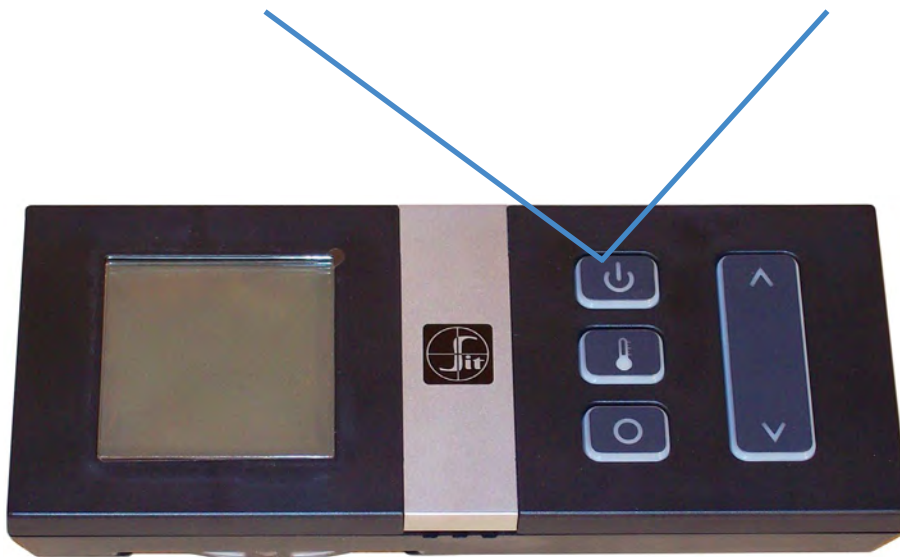

Figure 17.4.05:

Operation

Temperature Indication Display

With the system in the OFF position, press the Thermostat Key and the Mode Key at the same time to switch between Fahrenheit (F) or Celsius (C). Verify on the LCD screen the correct designation is visible.

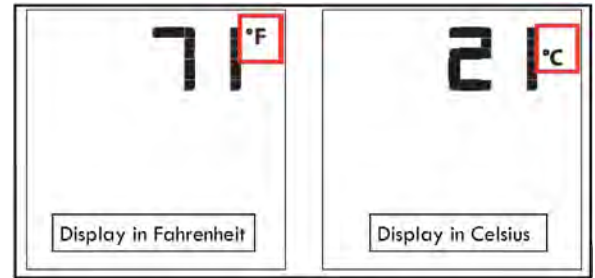

Figure 17.4.06:

Variable Flame Control

This function is disabled when in SMART Thermostat Mode and does not operate in the first two minutes of operation during the Dynamic Start Advantage.

The Proflame II IFC has six (6) flame levels. With the system ON and the flame at maximum in the appliance, pressing the Down Arrow Key once will reduce the flame height by one step. Repeat to lower the flame till OFF. With flame OFF in this configuration, fan and lights will still be operational.

The UP Arrow Key will increase the flame height each time it is pressed.

If the UP Arrow Key is pressed while the system is on but the flame is off, the flame will activate in the high setting.

A single beep will confirm reception of the command.

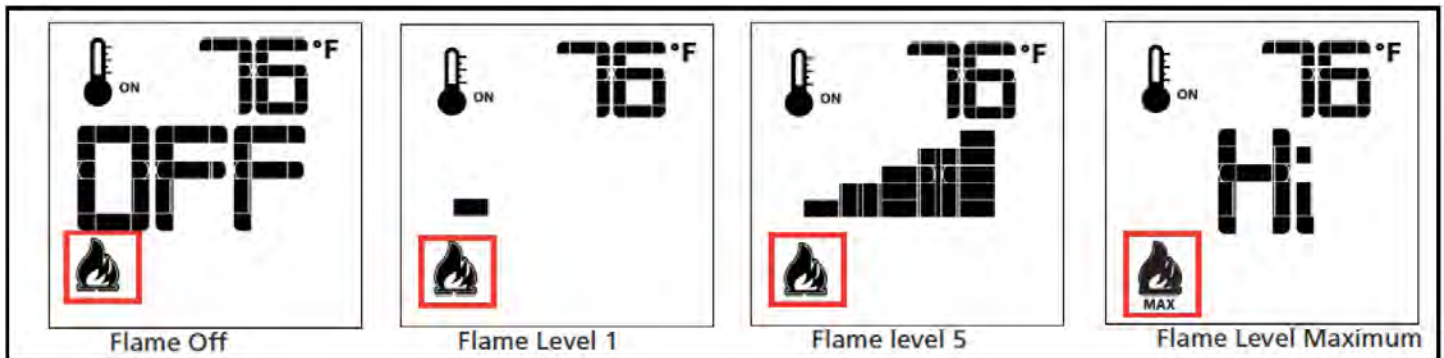

Figure 17.4.07:

Fan Speed Control

If the appliance is equipped with a hot air circulating fan, the speed of the fan can be controlled by the Proflame II system. The fan speed can be adjusted through six (6) speeds. To activate this function use the Mode Key to index to the fan control icon. Use the Up/Down Arrow Keys to turn on, off or adjust the fan speed. A single beep will confirm reception of the command.

In manual mode the fan will activate immediately upon burner ignition. Adjust the fan speed to personal preference. Blower will shut off when the burner is extinguished.

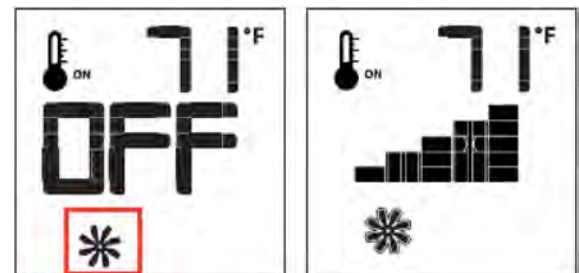

Figure 17.4.08:

Dimmer Control

This function is used to control the variable lights. To activate this function use the Mode Key to index to the variable light icon.

The intensity of the output can be adjusted through six (6) levels. Use the Up/Down Arrow Keys to adjust the output level. A single beep will confirm reception of the command.

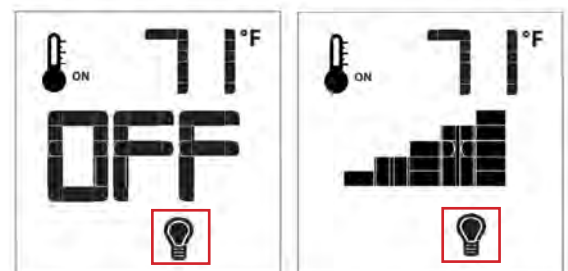

Figure 17.4.09:

Operation

Room Thermostat (Remote Operation)

The Remote Control can operate as a room thermostat. The thermostat can be set to a desired temperature to control the comfort level in a room.

To activate this function:

- Press the Thermostat Key. The LCD display on the remote will change to show that the room thermostat is ON and the set temperature is now active
- To adjust the temperature, press the Up/Down Arrow Keys until the desired temperature is displayed

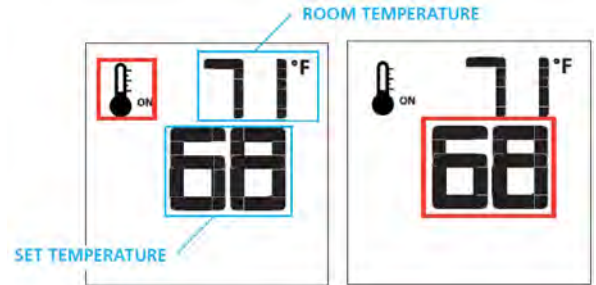

Figure 17.4.10:

SMART Thermostat (Remote Operation)

The Smart Thermostat function adjusts the flame height automatically in accordance to the difference between the set point and the actual room temperature. As the room temperature approaches the set point, the Smart Function will modulate the flame down.

To activate this function:

- Press the Thermostat Key until the word "SMART" appears to the right of the temperature bulb graphic
- To adjust the set temperature, press the Up/Down Arrow Keys until the desired set temperature is displayed

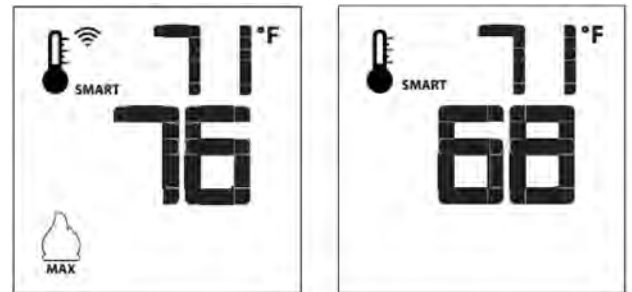

Figure 17.4.11:

NOTE

When the fireplace is started in Smart Thermostat mode:

1. The fan will automatically activate 5min after ignition and shut down 12min after fire is turned off.
2. Manual Flame height adjustment is disabled.

Continuous Pilot on Demand / Intermittent Pilot (CPI/IPI) Selection

With the system in "OFF" position press the Mode Key to index to the CPI mode icon.

Pressing the UP Arrow Key will activate the Continuous Pilot on Demand Ignition mode (CPI). Pressing the Down Arrow Key will return to IPI. A single "beep" will confirm the reception of the command.



Figure 17.4.12:

CPI vs IPI:

Continuous Pilot on Demand Ignition (CPI): In this mode the pilot runs continuously even when the main burner is off. The Continuous Pilot on Demand Ignition operates on a seven day cycle. If the main burner is not turned on for seven continuous days, the pilot will turn itself off. When the main burner is lit again the cycle repeats. The pilot will remain lit for seven days, even after the main burner is turned off. If the main burner is lit during a seven day timing cycle, the seven day timer will reset.

Intermittent Pilot Ignition (IPI): A fuel saving mode in which the pilot is only used when the main burner is on.

This appliance is shipped in IPI mode. IPI mode is often the preferred method, however, there are some situations where it may be preferable to switch the fireplace into CPI mode. For example, in colder climates the glass door or the front of the fireplace could become very cold to the touch. Dynamic Start Advantage will solve most problems experienced by older IPI operated fireplaces.

Operation

Automatic Safety Shut-Off

This system will execute an automatic turn OFF command after a 24hr continuous main burner flame ignition. This allows the system to verify correct safety functions.

Diagnostic Indications Information

LOW BATTERY CONDITION (Less than 4V):

Remote Control

- Battery Icon will appear on LCD remote control display. Replace batteries.

Battery Back-up

- Red LED indicator will enter a (1) blink sequence. IFC Module will emit a double-beep when it receives an ON/OFF command from the hand held remote. Replace batteries.

Pilot Flame Error Condition:

- Red LED Indicator will commence a (2) blink sequence. Contact your dealer if this occurs.

System Lock Out Condition:

- Red LED Indicator will commence a (3) blink sequence. Make sure your gas is turned on.
- Make sure pilot sensor is not shorted out.
- If the system is in a locked state, reset the IFC module as follows: Turn off all power to the IFC module for at least 2 seconds (including the backup battery pack), then restore power to the IFC module.

Key Lock

This function will lock the keys to avoid unsupervised operation.

- To activate this function, press the MODE and UP Keys at the same time
- To deactivate this function, press the MODE and UP Keys at the same time



Figure 17.4.13:

Low Battery Power Detection (Less than 4V)

Remote

The life span of the remote control batteries depend on various factors:

- Quality of the batteries used
- The number of ignitions of the appliance
- The number of changes to the room temperature set point, etc

When the Remote batteries are low, a Battery Icon will appear on the LCD display of the Remote before all battery power is lost. When the batteries are replaced this icon will disappear.



Figure 17.4.14:

BACKUP BATTERY PACK (used when 120V home electrical power is interrupted):

- Red LED indicator on the IFC Module will enter a (1) blink sequence
- Backup batteries lifespan depends on various factors including battery quality, number of ignitions, changes to room thermostat set point, etc. When batteries are low, a double beep will be emitted from the IFC control module when it receives an ON/OFF command from the remote control
- This is an alert for a low battery condition of the backup batteries and after this double-beep warning, no commands will be accepted until batteries are replaced
- When batteries are replaced a beep will be emitted from IFC control module as soon as powered

18.0 Maintenance

CAUTION:

Do not conduct maintenance on the appliance while it is operating or while it is still hot. Always verify proper operation after servicing.

18.1 Cleaning and Routine Maintenance

The exterior painted surfaces, glass, and metal plated trims may be cleaned with a soft, non-abrasive cloth and water or a suitable, mild, non-abrasive cleaner. Be sure there are no fingerprints left on the glass panels as high temperatures can bake these prints on permanently.

Regularly:

- Frequent cleaning of the ceramic glass is recommended. We recommend using a good quality ammonia free gas fireplace glass cleaner that is available at any hearth retail location. Take care to avoid scratching glass while cleaning. **DO NOT CLEAN WHILE HOT.** Never use common household cleaners to clean the glass.
- Keep the appliance area free from combustible materials, such as paper, wood, clothing, gasoline and flammable solids, liquids and vapors.
- Visually check the height and color of the burner and pilot flames.
- Touch up the paint when required using a high temperature satin black paint. Allow the paint to dry prior to lighting the fireplace.

Once a year, have a qualified service technician:

- Perform the regular services listed above.
- Inspect and operate the pressure relief mechanism (door buckles) to verify they are free from obstruction and operate properly.
- Carefully remove the logs and gently brush off any loose carbon deposits. This job is best done outside the house, wearing a dust mask. The logs are very fragile, take care not to break them. Do not wash logs with any liquid. While the logs are removed, check that all burner openings are not obstructed and it is recommended you use a vacuum cleaner to clean off any dust or lint.
- After cleaning, the logs and embers must be replaced according to the instructions in this manual.
- Vacuum and clean any lint accumulations or debris in the firebox, on the burners, on the pilot, at the primary air opening, on the convection air blower and in any combustion and convection air passageways.
- Inspect the operation of the flame safety system pilot and gas valve.
- Inspect and ensure the lighting of the main burner occurs within 4 seconds of the main gas valve opening. Flames should match those shown in **Figure 18.5.01**.
- Completely inspect the appliance and the venting system, if the vent pipe or seal is found to be defective, replace and or reseal (follow the instructions found in the venting instructions, **Section 10.0**).
- Inspect the condition of the vent and vent terminal for sooting or obstruction and correct if present.
- Test and measure the flame failure response time of the flame safety system. It must de-energize the safety shutoff in no more than 30 seconds.
- Check all accessible gas-carrying tubes, connections, pipes and other components for leaks.

WARNING: All parts removed or disturbed, including guards and grills, must be properly replaced after maintenance.

Service and repair must be conducted by a qualified service person. If these instructions are not followed, a fire or explosion may result, causing property damage, personal injury or loss of life.

18.2 Servicing Under Warranty

Before servicing, read the terms and conditions of the warranty at the back of this manual. Contact the authorized Archgard dealer where you purchased the appliance from and provide them with details of the problem, along with the initial installation information (from the front of this manual).

WARNING: Servicing of this appliance **must be conducted by a qualified service technician**. Improper servicing, adjustment or alteration of this appliance may cause property damage, personal injury or loss of life. All servicing should be conducted with the appliance cold. All replacement parts must be authorized by Archgard for suitability.

18.3 Checking Inlet and Outlet Pressure

1. Remove the surround.
2. The pressure test taps are located on the valve's front face. The inlet is marked "IN" and the outlet is marked "OUT". See **Figure 18.3.01**.
3. Loosen the set screw inside the tap with a 3/16" flathead screwdriver.
4. Connect a 1/4" (6 mm) rubber tube to the tap post and a manometer.
5. Verify that the readings obtained are within specs (as shown on the appliance rating plate)
6. Be sure to tighten the set screw inside the tap after you have finished taking pressure readings.
7. Check for leaks.

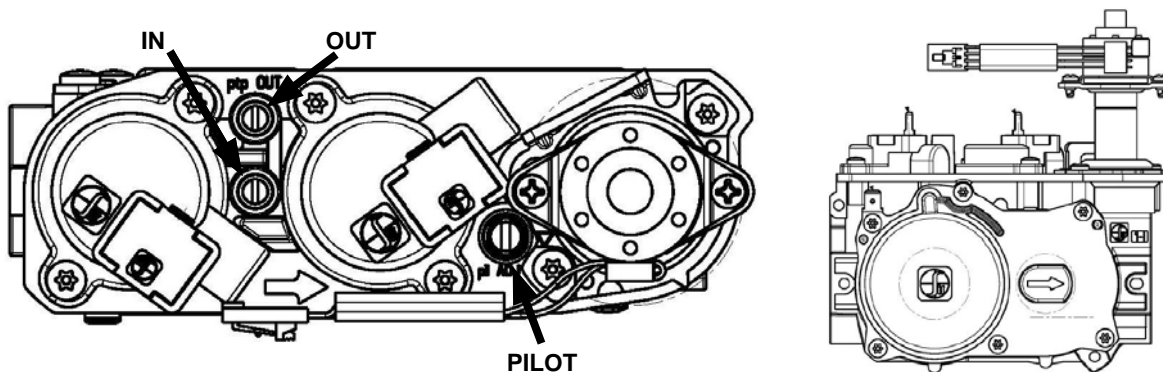

Figure 18.3.01

18.4 Checking and Adjusting Pilot

The pilot flames should have the characteristics shown in the illustration to the right.

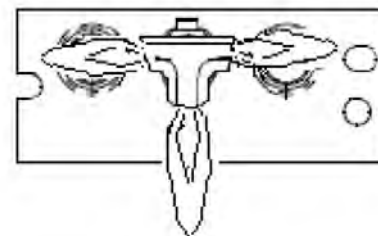

Figure 18.4.01

The flame should not have yellow tips but should engulf the flame sensor and spark electrode. It can be adjusted by turning the screw marked "pilot" on the control valve (See **Figure 18.3.01**).

It may be necessary to remove the pilot cover for a better view of the pilot flame (see next page).

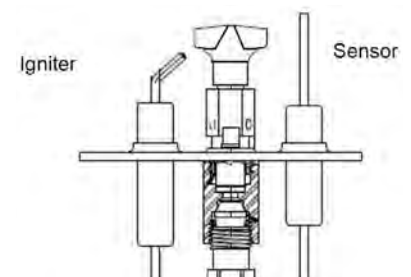

Figure 18.4.02

18.5 Adjusting the Primary Air

The 62-DVTE46CN-1 includes an air shutter located under the door of the fireplace which may be used to adjust the primary air to achieve the ideal flame as shown in **Figure 18.5.01**. To adjust, loosen the wing nut on the air shutter and adjust as shown in **Figure 18.5.02**. To open the air shutter and increase air flow to the burner, slide the air shutter to the left. To close the air shutter and decrease air flow to the burner, slide the air shutter to the right.

CAUTION: Do not adjust primary air below specified opening on the rating plate.

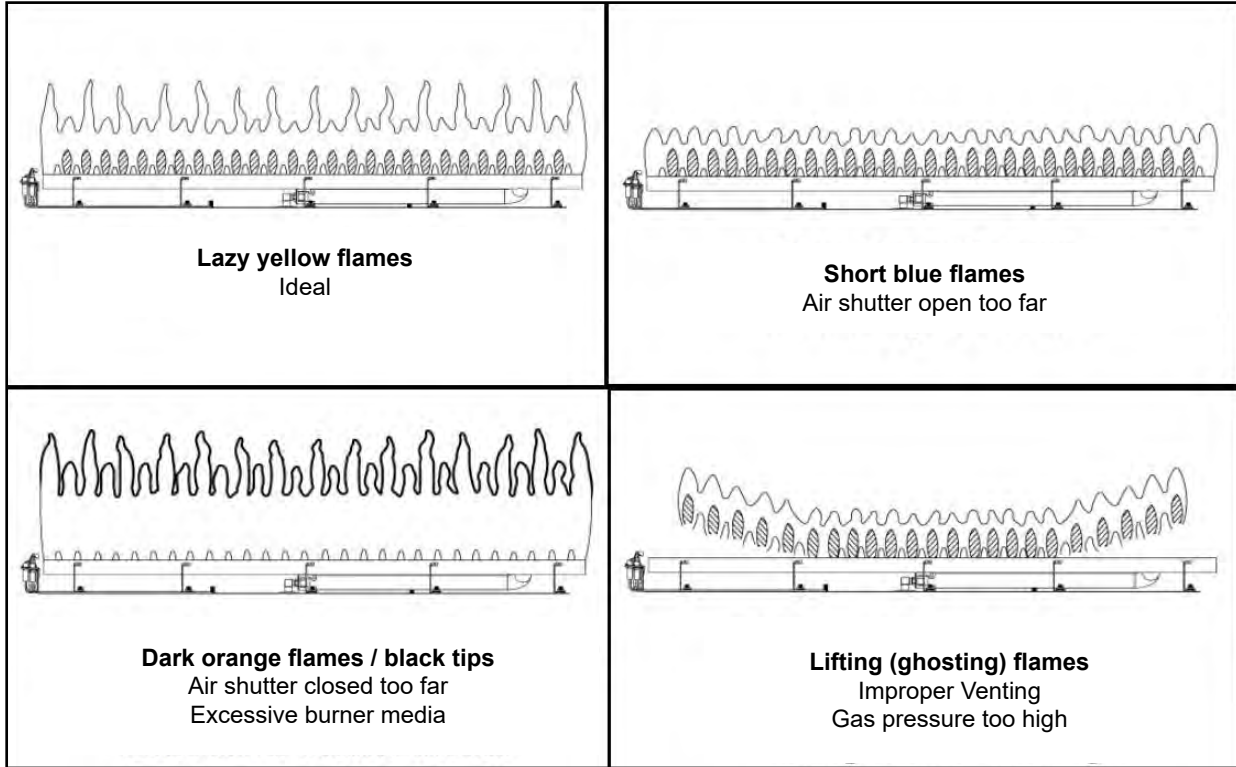

Figure 18.5.01:

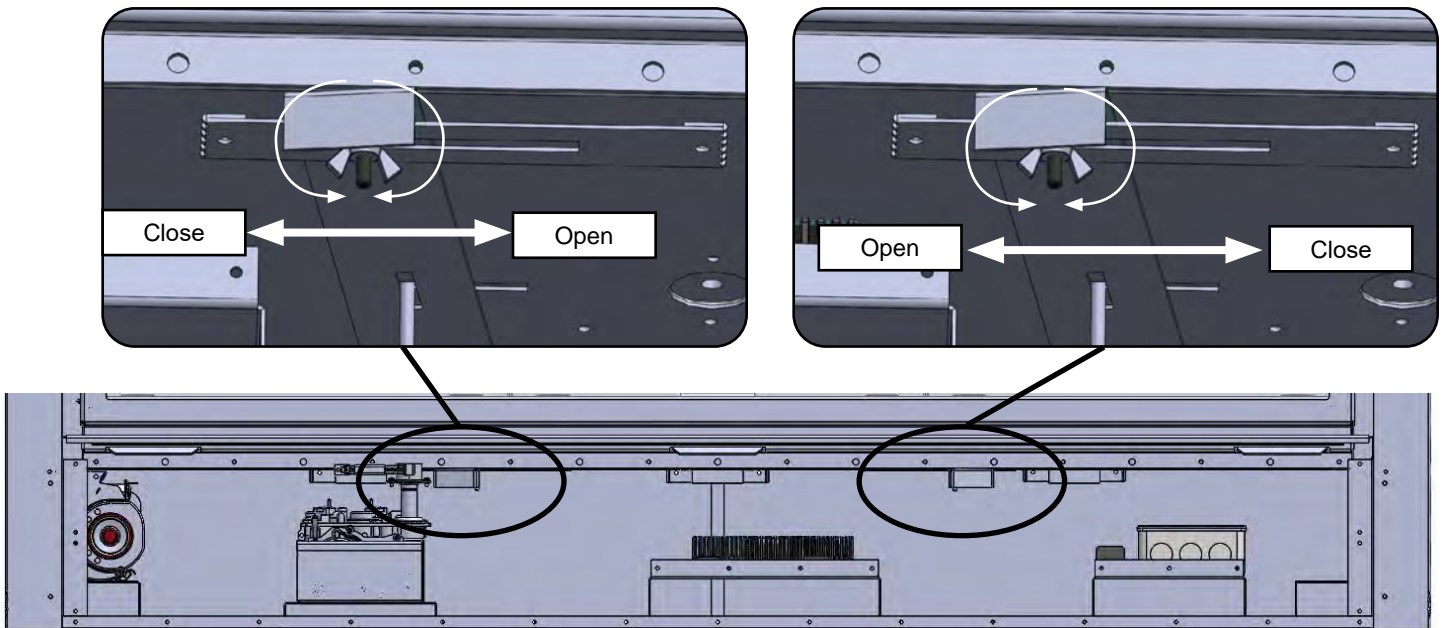

Figure 18.5.02:

18.6 Replacing Batteries

1. Disconnect power supply to the fireplace (including back-up batteries).
2. Ensure the fireplace is off and cool before servicing.
3. Turn off gas supply.
4. Remove the barrier screen (see **Section 6.3**).
5. Remove the valve blind (see **Section 6.5**).
6. Remove the battery holder from the retaining strap next to the receptacle.
7. Replace the batteries and tuck the battery holder back into the retaining strap.
8. Light the fireplace to verify proper operation. Resupply power once fireplace operation has been confirmed.
9. Replace the valve blind and barrier screen.



Figure 18.6.01:

Battery Specifications: 4 x AA Batteries

18.7 Replacing Fuse

1. Disconnect power supply to the fireplace (including backup batteries).
2. Ensure the fireplace is off and cool before servicing.
3. Turn off gas supply.
4. Remove the barrier screen (see **Section 6.3**).
5. Remove the valve blind (see **Section 6.5**).
6. Remove the fuse holder from the control board.
7. Replace the fuse with one which has the same specifications using the existing fuse holder.
8. Resupply power and light the fireplace to verify proper operation.
9. Replace the valve blind and barrier screen.

Fuse type: T3.15AL250V

Archgard Part Number: RP-305-2080

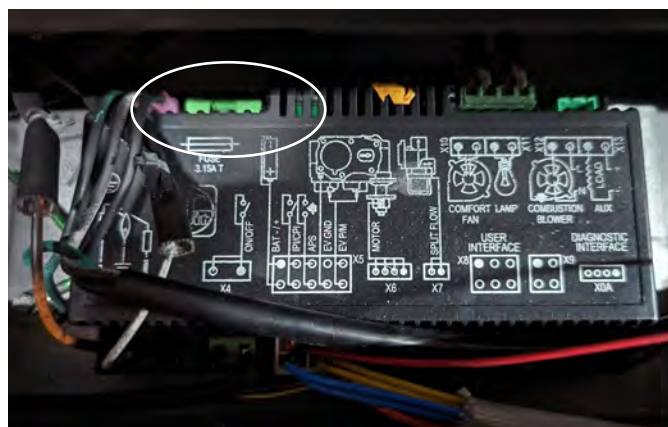

Figure 18.7.01:

18.8 Disabling CPI

CAUTION: Label all wires prior to disconnection when servicing controls. Wiring errors can cause improper and dangerous operation. Verify proper operation after servicing. This appliance, when installed, must be electrically grounded in accordance with local codes or, in the absence of local codes, with the **National Electrical Code, ANSI/NFPA 70, or the Canadian Electrical code, CSA C22.1.**

If you have to disable continuous pilot ignition (CPI) for any reason, follow the steps below:

1. Ensure the fireplace is off and cool before servicing.
2. Disconnect power supply to the fireplace (including backup batteries).
3. Turn off gas supply.
4. Remove the barrier screen (see **Section 6.3**).
5. Remove the valve blind (see **Section 6.5**).
6. Pull the blue CPI wire from the insulation sleeving and cut the wire. Protect both ends of the wire.
7. Replace the valve blind and barrier screen.
8. Resupply power and Light the fireplace to verify proper operation.

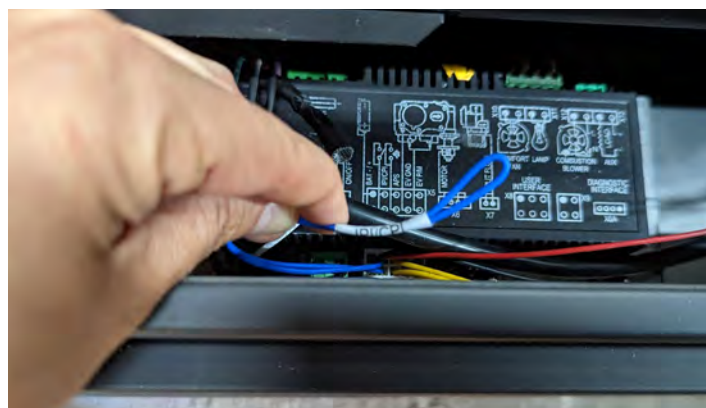

Figure 18.8.01:

18.9 Replacing Light Bulbs

Caution: Always handle bulbs with cotton gloves as finger prints may reduce the life of the bulb. We recommend replacing both bulbs at the same time.

1. **Ensure the fireplace is off and cool before servicing.**
2. **Disconnect power supply to the fireplace (including backup batteries).**
3. **Turn off gas supply.**
4. Remove the barrier screen (see **Section 6.3**).
5. Remove the valve blind (see **Section 6.5**).
6. Remove the glass door assembly (see **Section 6.4**).
7. Remove the firebox liner (see **Section 15**).
8. Remove the baffle (see **Section 18.12**).
9. Remove the light shield (see **Figure 18.9.01**)
10. Remove the old bulb from the bulb holder.
11. Replace with a bulb of the same specifications.
12. Reinstall the baffle and firebox liner.
13. Ensure burner media has not been disturbed.
14. Replace the glass door assembly, valve blind, and barrier screen.
15. Resupply power.
16. Light the fireplace to verify proper operation. See **Section 17.4** for information on using the remote to control the lights.



Figure 18.9.01:



Figure 18.9.02:

Bulb specification:	120V / 20W
	G6.35
	HALOGEN

18.10 Replacing the Control Board

CAUTION: Label all wires prior to disconnection when servicing controls. Wiring errors can cause improper and dangerous operation. Verify proper operation after servicing. This appliance, when installed, must be electrically grounded in accordance with local codes or, in the absence of local codes, with the **National Electrical Code, ANSI/NFPA 70, or the Canadian Electrical code, CSA C22.1.**

Before you begin:

- Ensure the fireplace is off and cool before servicing
- Disconnect power supply to the fireplace (including backup batteries)
- Turn off gas supply
- Remove the barrier screen (see **Section 6.3**)
- Remove the valve blind (see **Section 6.5**)
- Remove glass door (recommended, see **Section 6.4**)

Step 01: Remove the tek screw from the ground wire.

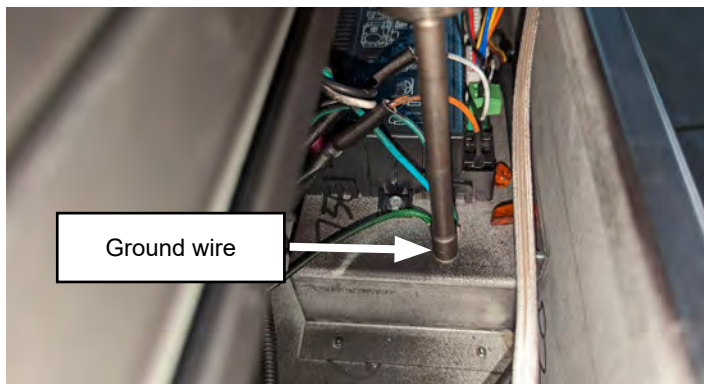

Figure 18.10.01:

Step 02: Remove the two tek screws securing the control board to the control board bracket.



Figure 18.10.02:

Step 03: Lift the control board from the fireplace.



Figure 18.10.03:

Step 04: Mark all the wires connected to the control board as you unplug them from the control board.

Step 05: Plug the wires into the new control board.

Step 06: Install the new control board using the tek screws previously removed.

Step 07: Secure the ground wires together using the tek screw previously removed.

Final steps:

- Replace the glass door (if removed, see **Section 6.4**)
- Replace the valve blind (see **Section 6.5**)
- Replace the barrier screen (see **Section 6.3**)
- Resupply gas to the fireplace
- Resupply power to the fireplace

18.11 Wiring Schematic

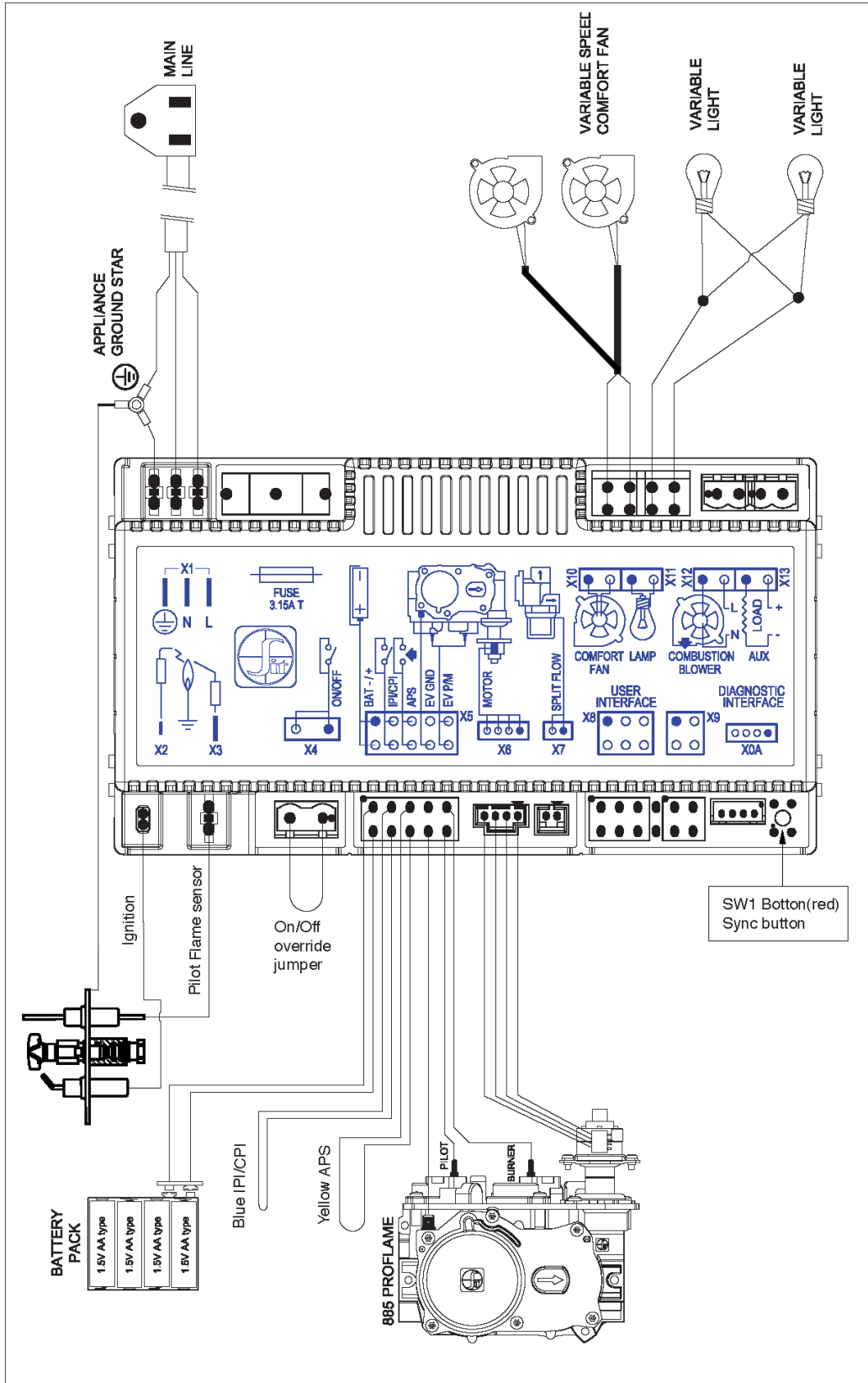

Figure 18.11.01

Maintenance

18.12 Removing the Baffle

The baffle located in the top of the firebox may need to be removed to service the appliance. Use the following instructions to remove the baffle.

Before you begin:

- **Ensure the fireplace is off and cool before servicing**
- **Ensure the gas supply is turned OFF and disconnect the power supply (including backup batteries)**
- Remove barrier screen (see **Section 6.3**)
- Remove the valve blind (see **Section 6.5**)
- Remove glass door (see **Section 6.4**)
- Remove burner media (see the Media installation manual)
- Remove panel set (if applicable - see **Section 15.0**)

Step 01: Support the baffle while removing the eight (8) phillips head screws from the front of the baffle and four (4) 1/4" Tek Screws from the baffle.

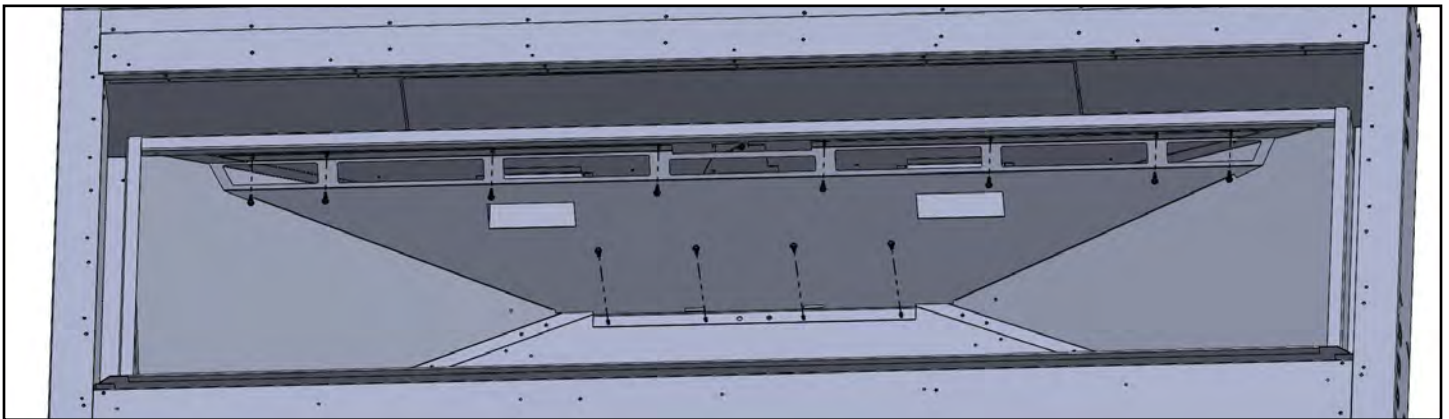

Figure 18.12.01:

Step 02: Remove the baffle.

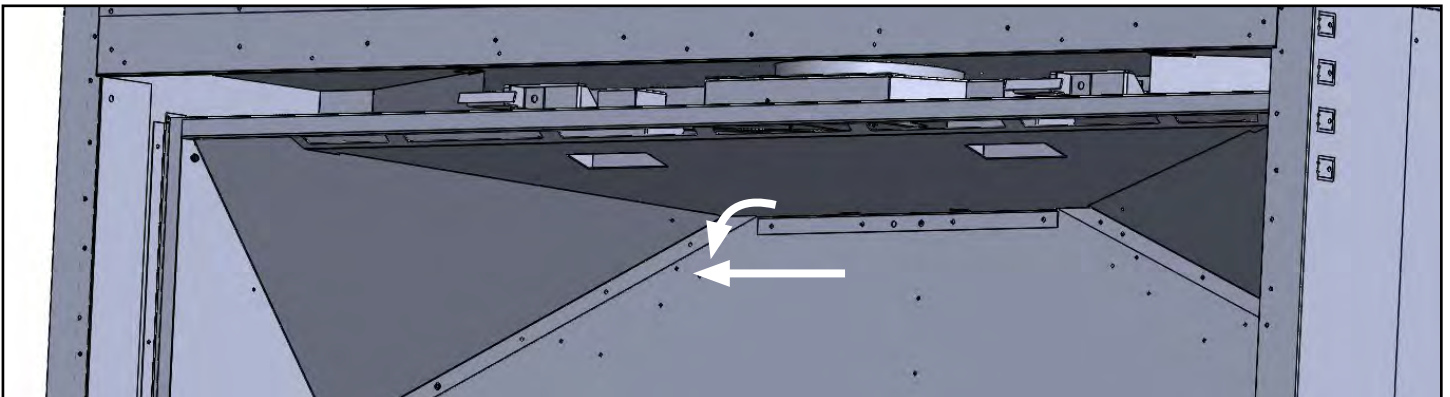

Figure 18.12.02:

Installation is the reverse of removal.

WARNING: All parts removed or disturbed, including guards and grills, must be properly replaced after maintenance. Service and repair must be conducted by a qualified service person. If these instructions are not followed, a fire or explosion may result, causing property damage, personal injury or loss of life.

18.13 Removing the Burner Surround

Before you begin:

- Ensure the fireplace is off and cool before servicing
- **Ensure the gas supply is turned OFF and disconnect the power supply (including backup batteries)**
- Remove barrier screen (see **Section 6.3**)
- Remove the valve blind (see **Section 6.5**)
- Remove glass door (see **Section 6.4**)
- Remove burner media (see the Media installation manual)
- Remove panel set (if applicable - see **Section 15.0**)
- Remove the pilot shield (see **Figure 18.13.01**)

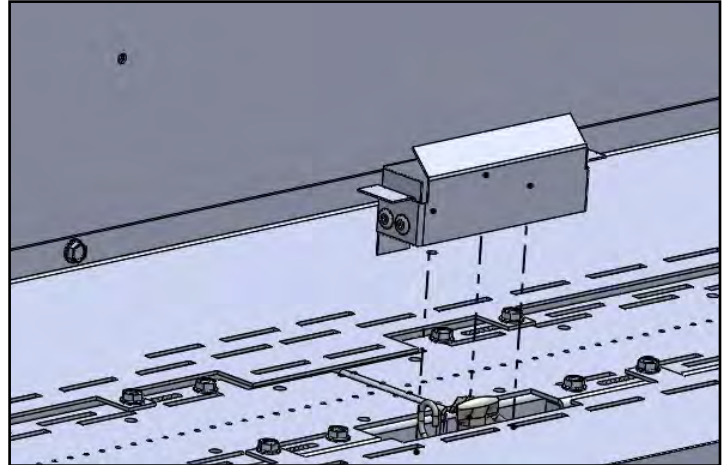

Figure 18.13.01: Pilot shield

The burner surround consists of two sections, split along the middle. To remove the burner surround, remove the 21 tek screws from around the edge of the surround and the 10 tek screws securing the burner surround to the burner.

Note: The burners have six (6) tek screws securing it in place (marked with "X"). Only remove the screws securing the surround to the burner. Do not remove the screws marked with "X" unless removing the burners as well.

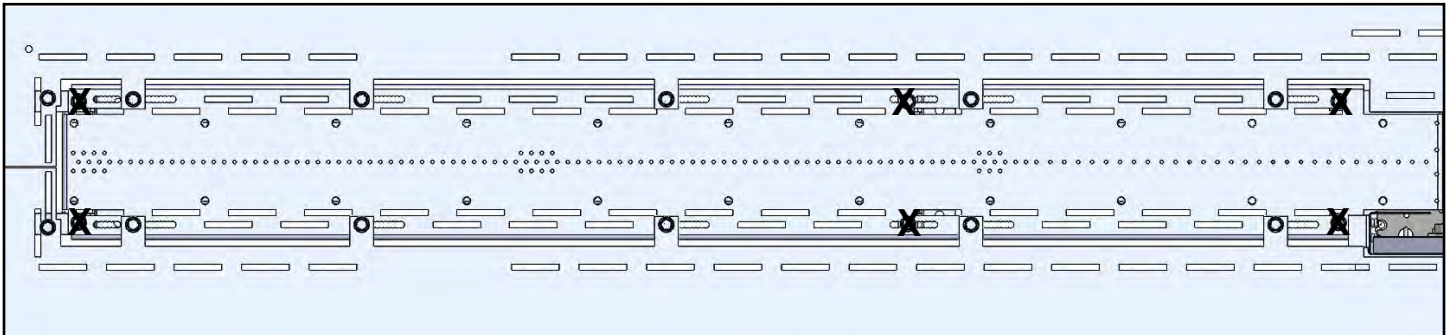

Figure 18.13.02: Left side of burner surround

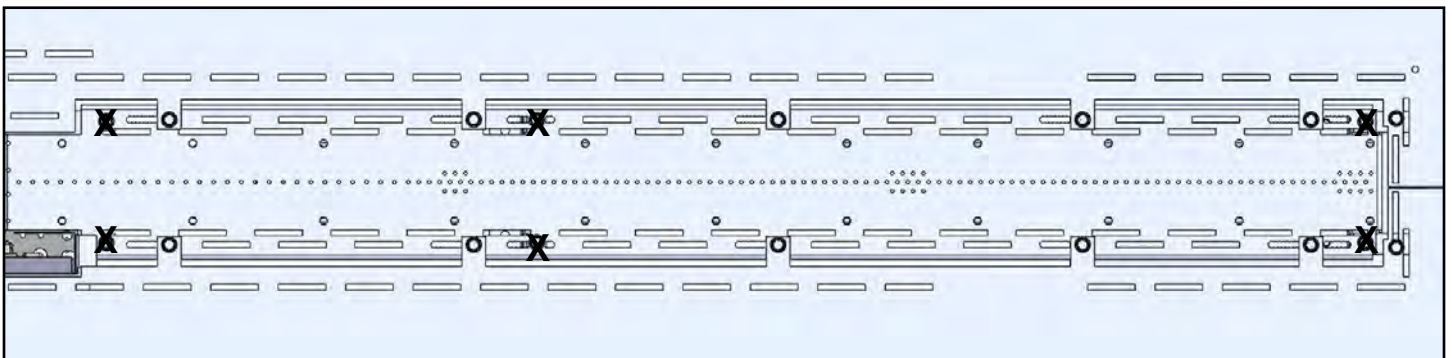

Figure 18.13.03: Right side of burner surround

Maintenance

Lift the front and rear sides of the burner surround up and out of the fireplace to remove.

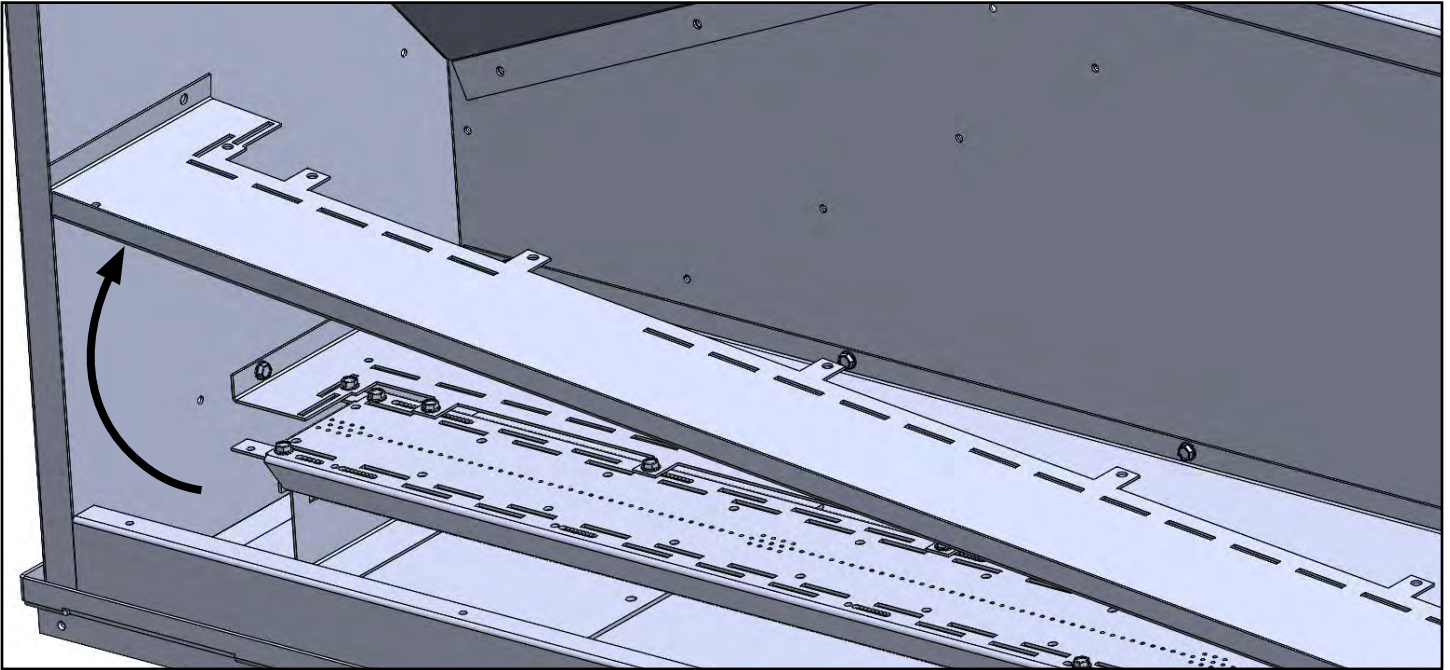

Figure 18.13.04: Front of burner surround

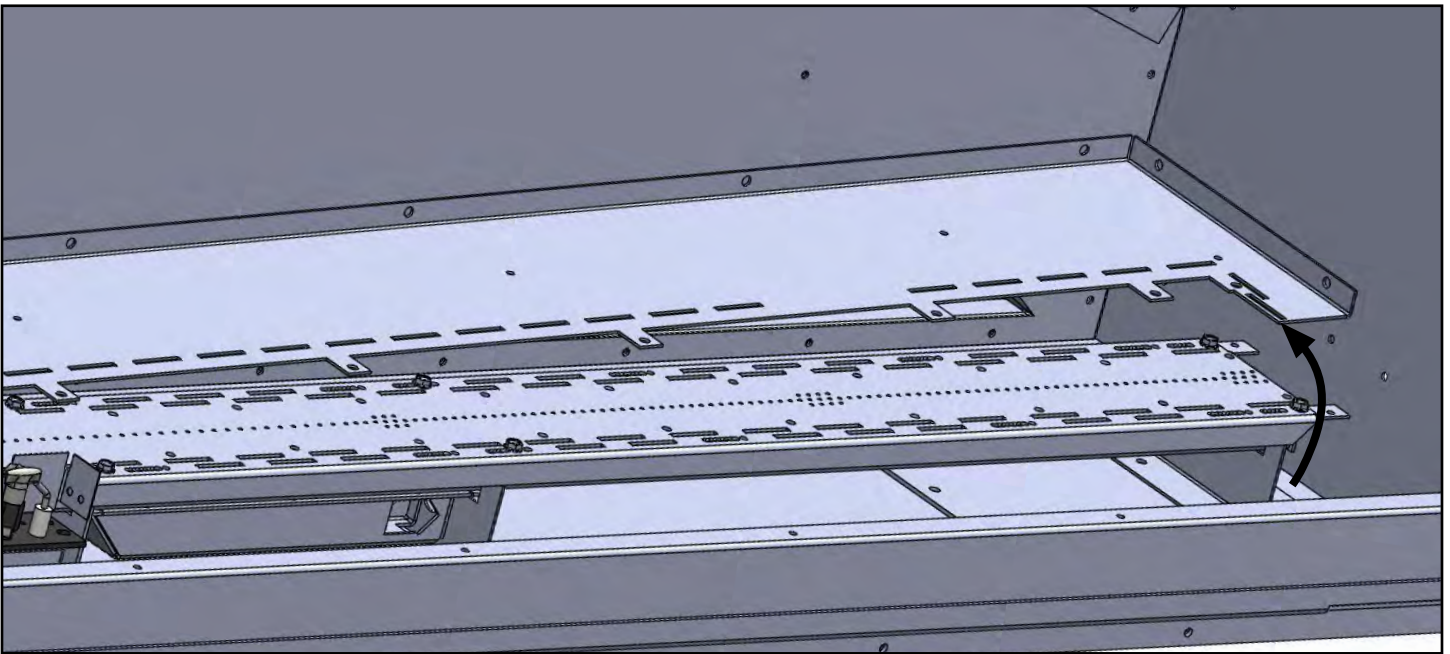

Figure 18.13.05: Back of burner surround

Installation is the reverse of removal.

18.14 Replacing the Burner

The Kōjin 62 includes two burners that meet in the middle to create the linear panoramic wall-to-wall fire. The following steps show the process for replacing the left side burner. Steps to replace the right side burner are identical.

Before you begin:

- Ensure the fireplace is off and cool before servicing
- **Ensure the gas supply is turned OFF and disconnect the power supply (including backup batteries)**
- Remove barrier screen (see **Section 6.3**)
- Remove the valve blind (see **Section 6.5**)
- Remove glass door (see **Section 6.4**)
- Remove burner media (see the Media installation manual)
- Remove panel set (if applicable - see **Section 15.0**)
- Remove the burner surround (see **Section 18.13**)

Step 01: Remove the six (6) tek screws securing each burner in place.

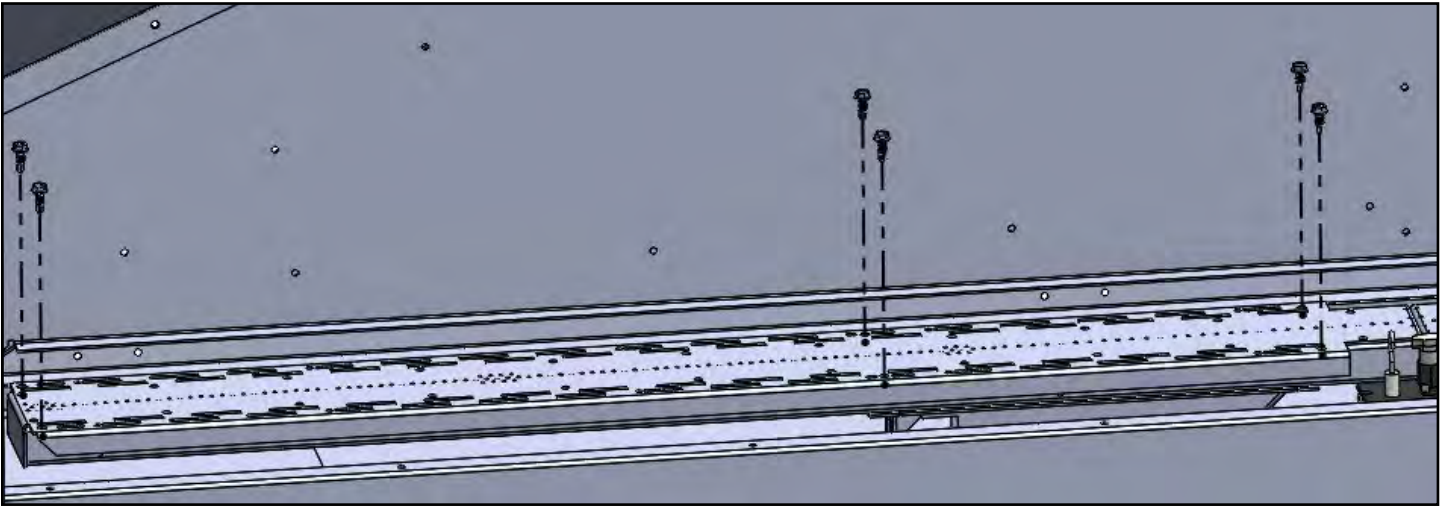

Figure 18.14.01:

Step 02: Lift the burners straight up and out of the fireplace to remove.

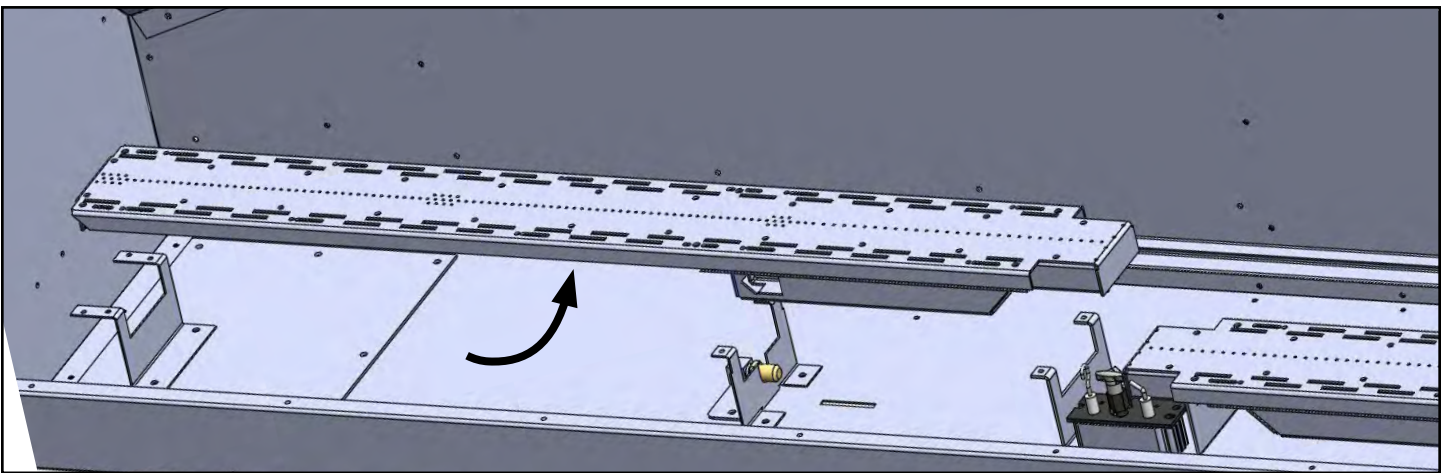

Figure 18.14.02:

Installation is the reverse of removal.
Check operation of air shutter when reinstalling the burner.
See **Section 18.5**.

18.15 Replacing the Fans

CAUTION: Label all wires prior to disconnection when servicing controls. Wiring errors can cause improper and dangerous operation. Verify proper operation after servicing. This appliance, when installed, must be electrically grounded in accordance with local codes or, in the absence of local codes, with the **National Electrical Code, ANSI/NFPA 70, or the Canadian Electrical code, CSA C22.1.**

The Kōjin 62 includes two fans located under fan access plates in the bottom of the firebox. The following steps show the process for replacing the left side fan. Steps to replace the right side fan are identical.

Before you begin:

- Ensure the fireplace is off and cool before servicing
- **Ensure the gas supply is turned OFF and disconnect the power supply (including backup batteries)**
- Remove barrier screen (see **Section 6.3**)
- Remove the valve blind (see **Section 6.5**)
- Remove glass door (see **Section 6.4**)
- Remove burner media (see the Media installation manual)
- Remove panel set (if applicable - see **Section 15.0**)
- Remove the burner surround (see **Section 18.13**)
- Remove the burner (see **Section 18.14**)

Step 01: Remove the eight (8) tek screws securing the fan access plate on each side of the firebox bottom.

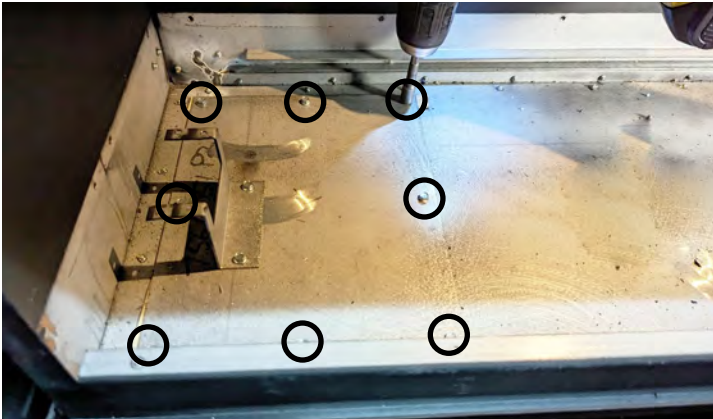

Figure 18.15.01: Left side fan access plate



Figure 18.15.02: Right side fan access plate

Step 02: Remove the fan access plate.



Figure 18.15.03:

Step 03: Remove the two (2) wingnuts securing the fan to the fan mounting bracket.



Figure 18.15.04:

Maintenance

Step 04: Slide the fan forward, rotate, and pull from the bottom of the firebox.

Step 05: Unplug the fan.



Figure 18.15.05:

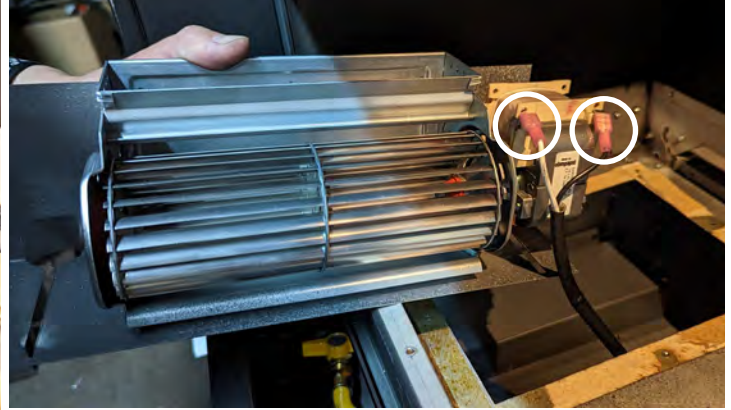

Figure 18.15.06:

Step 06: Remove the gasket from the back of the fan bracket and remove the three (3) tek screws securing the fan to the bracket.

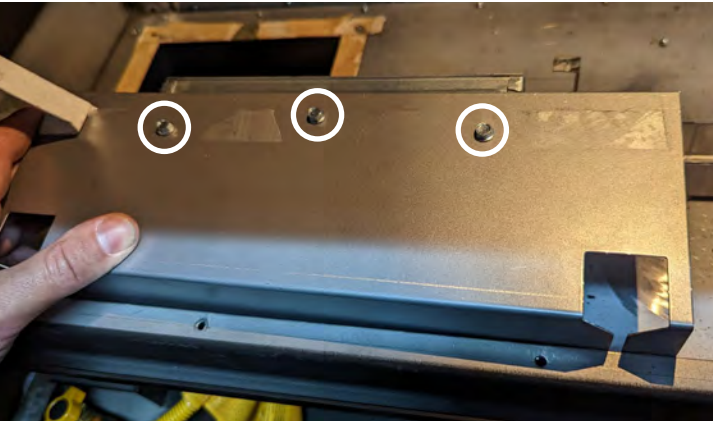

Figure 18.15.07:

Installation is the reverse of removal.
Replace gasket on the fan bracket during reinstall.

18.16 Replacing the Pilot

Before you begin:

- Ensure the fireplace is off and cool before servicing
- **Ensure the gas supply is turned OFF and disconnect the power supply (including backup batteries)**
- Remove barrier screen (see **Section 6.3**)
- Remove the valve blind (see **Section 6.5**)
- Remove glass door (see **Section 6.4**)
- Remove burner media (see the Media installation manual)
- Remove panel set (if applicable - see **Section 15.0**)
- Remove the burner surround (see **Section 18.13**)
- Remove the burner (see **Section 18.14**)

Step 01: Remove the two (2) tek screws securing the pilot to the pilot extrusion.

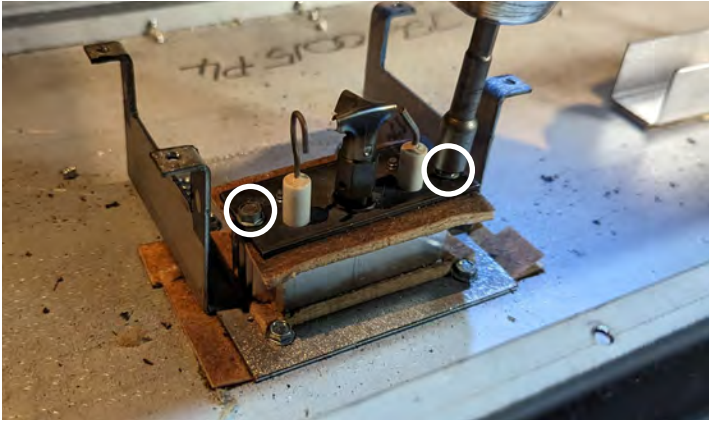

Figure 18.16.01:

Step 02: Pull the pilot up and use a 1/2" wrench to hold the pilot and a 7/16" wrench to remove the pilot gas line.



Figure 18.16.02:

Step 03: Unplug the pilot wires.

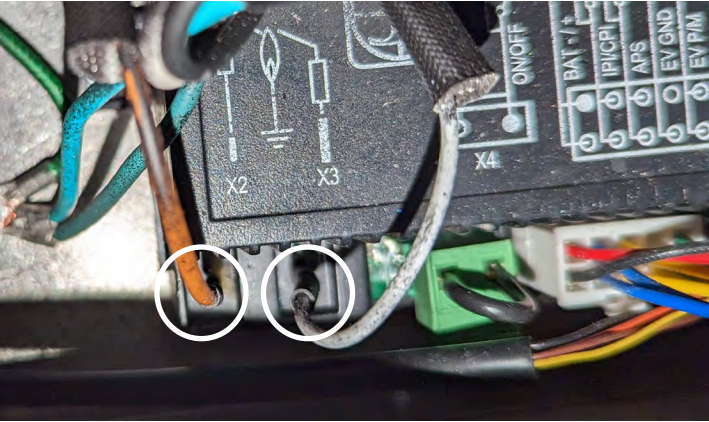

Figure 18.16.03:

Step 04: Remove the screw securing the ground wire to the pilot.

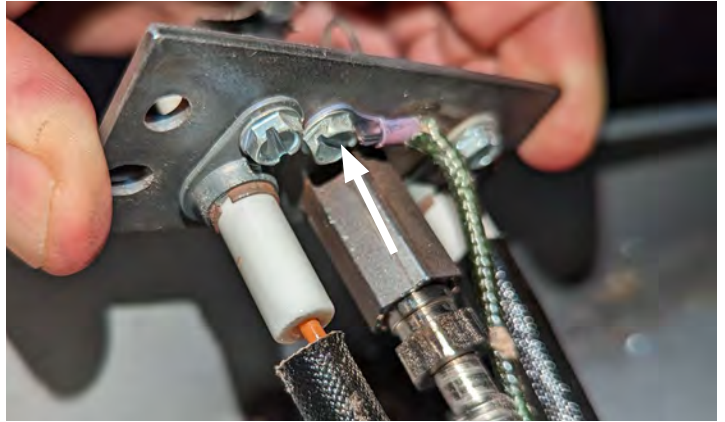

Figure 18.16.04:

Installation is the reverse of removal.

CAUTION: Label all wires prior to disconnection when servicing controls. Wiring errors can cause improper and dangerous operation. Verify proper operation after servicing. This appliance, when installed, must be electrically grounded in accordance with local codes or, in the absence of local codes, with the **National Electrical Code, ANSI/NFPA 70, or the Canadian Electrical code, CSA C22.1.**

18.17 Replacing the Light Bases

The following steps describe the process for replacing the light bases. The left side light base is shown, however, the process is the same for the right side.

Before you begin:

- Ensure the fireplace is off and cool before servicing
- **Ensure the gas supply is turned OFF and disconnect the power supply (including backup batteries)**
- Remove barrier screen (see **Section 6.3**)
- Remove the valve blind (see **Section 6.5**)
- Remove glass door (see **Section 6.4**)
- Remove panel set (if applicable - see **Section 15.0**)
- Remove the baffle (see **Section 18.12**)
- Remove the light shields (see **Section 18.9**)
- Remove the fan access plate (see **Section 18.15**)

Step 01: Remove the four (4) tek screws securing the light base to the top of the firebox.

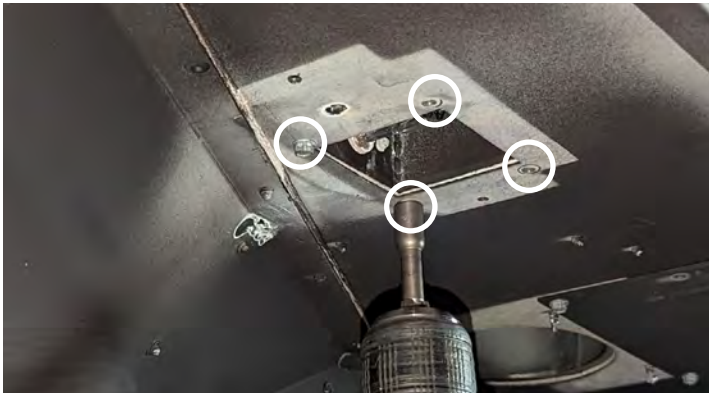

Figure 18.17.01:

Step 02: Use a long screwdriver to pull the light wire up and out of the retainer bracket at the back of the air box.



Figure 18.17.02:

Step 03: Partially reinsert one tek screw. This will allow the light box to pivot.

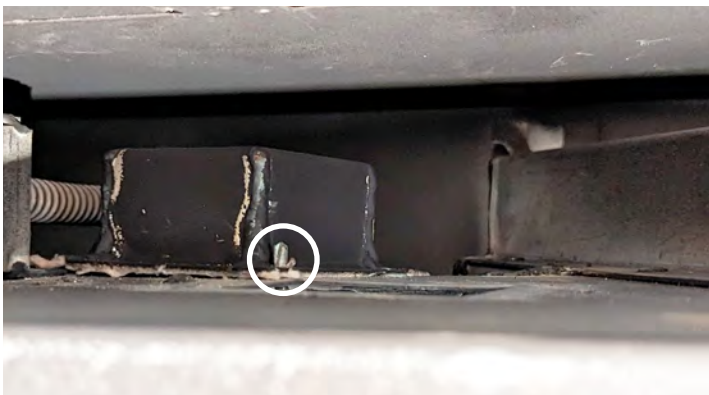

Figure 18.17.03:

Step 04: Reach through the fan access opening and pull the light wire out to unplug.



Figure 18.17.04:

Step 05: Remove the tek screw that was partially reinserted in **Step 03** and pull the light box from the fireplace.

Installation is the reverse of removal.
Be sure to route the wire through the retainer at the back of the airbox.

CAUTION: Label all wires prior to disconnection when servicing controls. Wiring errors can cause improper and dangerous operation. Verify proper operation after servicing. This appliance, when installed, must be electrically grounded in accordance with local codes or, in the absence of local codes, with the **National Electrical Code, ANSI/NFPA 70, or the Canadian Electrical code, CSA C22.1.**

Maintenance

18.18 Troubleshooting

Issue	Solution
The pilot igniter won't spark.	<ol style="list-style-type: none"> 1. Ensure the ON/OFF override jumper is installed correctly. 2. Ensure main power is ON and new batteries are installed in the remote control (3 x AAA) and backup battery pack on the control board (4 x AA). 3. Make sure remote is synced with control board. 4. Check the 3.15A fuse in the control board. Replace the fuse if necessary. 5. Make sure remote is not in smart or thermostat mode. 6. Ensure igniter wire is connected to the control board and is not damaged.
The pilot igniter sparking, but the pilot will not light.	<ol style="list-style-type: none"> 1. Verify the inlet gas pressure is within acceptable limits. 2. Check all connections to the gas valve. 3. Ensure fuel supply valves and emergency shut-off valve are open. 4. Check wiring connections from control board to valve. 5. Check that the pilot is set to the correct fuel. 6. Ensure pilot head is clear of debris.
The pilot lights, but the main burner will not light.	<ol style="list-style-type: none"> 1. Check and verify all wiring connections match the wiring diagram. 2. Verify the inlet and manifold pressure are within acceptable limits.
The pilot lights, but the main burner will not light and igniter continues to spark.	<ol style="list-style-type: none"> 1. Check the pilot flame sensor rod and clean with steel wool or similar if dirty. 2. Check the pilot hood and clean with steel wool if dirty. 3. Ensure the flame sensor wire is plugged into the control board and is not damaged. 4. Adjust pilot flame using the pilot adjustment screw if the pilot flame is too long or too short (the flame should fully engulf the sensor rod and must be stable). 5. Check supply pressure. 6. Ensure the ground wire from the pilot is connected to the fireplace ground location.
The pilot was lit but will randomly go out.	<ol style="list-style-type: none"> 1. Turn the fireplace on again. If the fireplace is in continuous pilot on demand ignition mode, the system will turn off the pilot if the fireplace has not been used for seven days. You may also switch the fireplace to IPI mode (See Section 17.4). 2. Have a service technician check for low inlet pressure.
The flames on the main burner are low even though the remote is on high.	<ol style="list-style-type: none"> 1. Wait two minutes. Dynamic Start Advantage is designed to build a draft by starting on low and automatically increasing the flame size to the setting on the remote after two minutes. This system helps to create a better flame appearance, reduce condensation on the glass, and provide years of carefree operation. 2. Have a service technician check for low inlet pressure. 3. Replace the valve motor.
Fans do not work.	<ol style="list-style-type: none"> 1. Ensure main power is ON and the fireplace is plugged in (the fireplace may be operating on back up batteries). 2. Check the 3.15A fuse in the control board and replace if necessary. 3. Ensure the fans are connected to the control board.
Lights do not work.	<ol style="list-style-type: none"> 1. Ensure main power is ON and the fireplace is plugged in (the fireplace may be operating on back up batteries). 2. Check the 3.15A fuse in the control board and replace if necessary. 3. Ensure the lights are connected to the control board. 4. Replace the bulbs (bulbs may be burnt out).
Control module beeps twice when On/Off button on remote is pressed and Red LED is On.	<ol style="list-style-type: none"> 1. Replace batteries in remote battery pack.

All service and repairs should be performed by a qualified and licensed service technician.

19.0 Frequently Asked Questions

Listed below are some frequently asked questions regarding Archgard Gas Fireplaces. If you have questions that are not listed below, or are not answered in this manual, please contact your Authorized Archgard Dealer.

Q. My glass has a condensation “fog” when the appliance is first lit.

A. Condensation is normal and will disappear in a few minutes after the glass is heated. This can be reduced if the appliance is left in CPI mode.

Q. I have a white “film” on my glass. What is the best way to clean the inside of the glass?

A. Frequent cleaning of your glass is recommended. The white film cannot be removed using standard household glass cleaner. We recommend using a good quality, ammonia-free gas fireplace glass cleaner which is available at all authorized Archgard dealers. Do not use abrasive materials, and do not clean the glass or the appliance when the unit is hot. Never use ammonia based cleaners to clean the glass door.

Q. How do I care for my plated trims?

A. We recommend a cleaning with a damp cloth. DO NOT use chemical cleaners as they may harm the finish, and void your warranty. **NOTE:** If the top louvers, or top overlay starts to discolor, check the glass door gasket seal and contact your local Archgard dealer to replace if necessary.

Q. My fan/blower makes a “whirring” or “humming” noise.

A. Your Archgard gas appliance uses a powerful fan to push heated air into your room. It is not unusual to hear a “humming” noise when your fan is running. Note: the sound will change depending on the setting that your fan speed control is set at.

Q. I hear a “ticking”, “cracking” or “pinging” sound when my fireplace is running, and after it is turned off.

A. The different gauges of steel used to manufacture your fireplace will expand and contract at different rates when your fireplace is on, and will continued as your fireplace completes its heating function. You will likely hear these same sounds more on start up and shut down. This is normal for steel fireplaces.

Q. I hear a “click” when my main burner turns ON or OFF.

A. Your Gas Control Valve will make a clicking sound when it opens to allow gas to flow to the main burner. This is a normal part of the operating system.

Q. Can I burn wood and other materials in my gas fireplace?

A. No! Burning anything other than the fuel (natural gas or propane) the fireplace is setup for will create a potential fire hazard and present a danger to your home and its occupants and possibly void your manufacturer’s warranty. Only burn the gas fuel for which the unit was originally designed.

Q. Can I shut my pilot off in the summer?

A. You will save energy by turning off the pilot light if you are not using your appliance for the hot summer months. When in continuous pilot ignition on demand (CPI) mode the pilot will remain lit for seven days after the fireplace is used. When seven days have passed the system will turn the pilot off. When in IPI mode, the pilot will only remain on when the main burner is on.

Q. Why does my fireplace start with a low flame? Shouldn’t the flame size match the remote setting?

A. Dynamic Start Advantage was designed to create a draft by starting the fireplace on low and automatically increasing the flame to match the remote setting after two minutes. This system helps to create a better flame appearance, reduce condensation on the glass, and provide years of carefree operation.

Q. Can I position my logs in a different fashion or use a different log set?

A. No. Your gas fireplace is an engineered system that includes the firebox, burner, logs, venting and options which are tested and listed with a certification agency. Changing any specifications or placement of the logs could cause injury or damage, void your manufacturer’s warranty, and possibly even your homeowner’s warranty. Use only burner media that is approved for this fireplace. Contact your local Archgard dealer for information on burner media that is approved for this model.

20.0 Replacement Parts List

Item #	Item Description	Unit
200-0284-03	English Owner's Manual	EA
200-0284F-03	French Owner's Manual	EA
200-0282-02	Kōjin English Media Installation Manual	EA
200-0282F-02	Kōjin French Media Installation Manual	EA
308-6027	SIT 885 Gas Valve c/w Step Motor - NG	EA
308-6024	Wall Mount Remote	EA
308-6060	SIT Proflame II Dynamic Start Advantage with Continuous Pilot on Demand	EA
308-6012	Module Main Wiring Harness (5 wire)	EA
305-0060	Battery Back-up	EA
RP-305-2080	Fuse, 3.15A, 250V (Pack of 5)	EA
301-0068-42	Orifice - #42 DMS (2.4 mm) for Natural Gas (two per fireplace)	EA
301-0068-53	Orifice - #53 DMS (1.5 mm) for Propane (two per fireplace)	EA
308-0124	Pilot Assembly	EA
308-0125	PSE Spark Ignighter	EA
308-0126	PSE Flame Sensor	EA
314-0139	Pilot Gasket	EA
301-6242	Pilot Gas Line	EA
RP-862-0060	Burner Assembly (universal fit for left side or right side, 2 burners per fireplace)	EA
RP-836-0180	Light Base	EA
305-6314	Light Bulb (120V / 20W / G6.35)	EA
62-CKENG	Conversion Kit LP to NG	EA
62-CKELP	Conversion Kit NG to LP	EA
RF-305-0024	Replacement Fan (universal fit for left side or right side, 2 fans per fireplace)	EA
RP-862-0000	Complete Replacement Glass Door Assembly. Includes glass, gasket and door frame (black)	EA
62-BS	Premium Barrier Screen with Invisimesh	EA
62-FSGPB	Grandview Park Black Decorative Front	EA

Warranty

This Limited Warranty is made by ARCHGARD INDUSTRIES LTD., hereinafter referred to as "Archgard". Archgard warrants to the original purchaser of an Archgard gas burning fireplace(s) that the product will be free from defects in materials and workmanship under normal use and service, for a "lifetime". All warranty repairs are to be performed by an authorized Archgard Dealer during the warranty period. Other repair / service company charges for any work done during the warranty period, will be the responsibility of the home owner.

INCLUSIONS: "LIFETIME LIMITED WARRANTY"

- All heat exchangers and combustion chamber
- Ceramic Fiber Logs and Ceramic Brick Panels, against splitting and cracking due to heat exposure

NOTE: Discoloration and some minor movement including warping of certain parts are normal and are not a defect; therefore, not covered under warranty.

INCLUSIONS: "SEVEN YEAR LIMITED WARRANTY"

- Burner tubes and pans

INCLUSIONS: "TWO YEAR LIMITED WARRANTY"

- Ceramic Glass against thermal breakage
- Trims and accessories from splitting or separating
- Electronic Control Module, Remote Transmitter

Items included with ten-year and two-year limited warranty will be covered under "Parts & Subsidized Labour" to the original purchaser for one (1) year and "Parts Only" thereafter from original date of purchase.

INCLUSIONS: "ONE YEAR LIMITED WARRANTY"

- Blowers, fans and fan motors, wiring, rheostats and thermodiscs
- Rocker switches, spill switches and wiring to them
- Gas control valves, pilot assemblies including thermopiles, thermocouples, electrodes and igniters
- Paint peeling or cracking

Items included in the one-year limited warranty will be covered under "Parts & Subsidized Labour" to the original purchaser for one (1) year from date of purchase.

WHAT TO DO IN THE EVENT OF A PROBLEM:

- Thoroughly read your "Owner's Installation, Operation & Maintenance Manual"
- If you cannot solve the problem, contact your Archgard dealer or representative
- When calling for assistance, please have the following information:

Model of your fireplace Serial Number Place of Purchase
Date of Purchase Problem Description

NOTE: Warranty will be void if work is carried out by an unqualified person(s). Only original Archgard parts may be used. Please consult your Archgard dealer or representative if in doubt about a replacement part(s).

- All warranty repairs are to be performed by an authorized Archgard Dealer during the warranty period. Other repair / service company charges for any work done during the warranty period, will be the responsibility of the home owner.

OBTAINING WARRANTY SERVICE:

The original purchaser shall return the defective part(s) to the original authorized Archgard dealer – transaction prepaid, along with the serial number of the appliance and original proof of purchase. Any defective part, in our judgment, will be repaired or replaced at Archgard's discretion. The dealer must obtain approval from Archgard before any repairs are made.

WARRANTY LIMITATION:

THIS LIMITED WARRANTY IS MADE IN LIEU OF ALL OTHER WARRANTIES, EXPRESSED OR IMPLIED AS TO QUALITY, MERCHANTABILITY OR FITNESS FOR PARTICULAR PURPOSE.

The appliance is only warranted for the use as intended by the installation and operating instructions and local building codes. The warranty will not cover damage due to accident, misuse, abuse, alteration, improper installation or "Acts of God". This limited warranty is void unless the appliance is installed by a qualified Archgard installer, in accordance with the instructions furnished with the appliance. Some Provinces or States do not allow limitations on how long an implied warranty lasts, so the above limitations may not apply to the original purchaser. Any damage resulting from defects in this product is limited to the replacement of the defective part(s) and does not include incidental and consequential exposures sustained in connection with the product. This includes facing(s), mantle(s), cabinet(s), tile(s) or any other finishes resulting from removal of any gas appliance. This warranty is limited to residential use only and gives the consumer specific rights. These rights may vary from State to State or Province to Province.

WARRANTY CONDITIONS & REQUIREMENTS:

1. You are the original purchaser – this warranty is not transferable.
2. Installation of the fireplace must be performed by a qualified Archgard installer.
3. Installation and operation must comply with the installation and operation instructions.
4. All optional accessories are covered for one (1) year from the date of purchase.
5. This warranty does not offer coverage for light bulbs or batteries (whether factory, dealer, or installer supplied). This includes any damage stemming from non-use.
6. Damage during shipping or handling of components, defects resulting from improper installation or service, or misuse of the fireplace or fireplace components are not covered under this warranty.
7. This warranty does not cover any part of the fireplace or any component which has been exposed to or submerged under water.
8. Archgard must be notified by the dealer the fireplace was purchased from or a qualified Archgard technician of the defect.
9. Annual service of the fireplace as required in the installation manual must be performed by a qualified Archgard technician (service records may be required to claim a warranty).
10. All previous warranty service must have been performed by a qualified Archgard technician (service records may be required to claim a warranty).
11. Travel time or mileage to the original purchaser's residences is not covered under this warranty. We suggest that you pre-arrange travel expenses with your Authorized Archgard Dealer.
12. Freight on warranty shall be covered for the first two years of the warranty period.

POSTAGE

WARRANTY REGISTRATION

ARCHGARD INDUSTRIES LTD.
PO BOX 318
RAYMOND, AB
T0K 2S0

CUT ALONG LINE

FOLD DOWN AT LINE

CUT ALONG LINE

FOLD DOWN AT LINE & TAPE CLOSED

Model # : _____ Serial #: _____ Date Installed: _____ / _____ / _____

Name: _____ Address: _____

City: _____ State/Prov: _____ ZIP: _____ Phone: (_____) _____

Dealer's Name & Address: _____

City: _____ State/Prov: _____ ZIP: _____ Phone: (_____) _____

Installer's Name & Address: _____

City: _____ State/Prov: _____ ZIP: _____ Phone: (_____) _____

Why did you choose this product? _____

CUT ALONG LINE

*Thank you for purchasing our product and filling out this warranty card. Save time by completing this form at
www.archgard.com/warranty-registration*

ARCHGARD INDUSTRIES LTD.

300 RAILWAY AVENUE
RAYMOND, AB T0K 2S0
CANADA

WWW.ARCHGARD.COM