

INSTALLATION, OPERATION, AND MAINTENANCE MANUAL

Chantico 36

Model: 36-DVIE40LN-1
 GAS FIRED DIRECT VENT
 FIREPLACE INSERT
 S/N 360636 AND UP



WARNING: If the information in this manual is not followed exactly, a fire or explosion may result causing property damage, personal injury or loss of life.

Do not store or use gasoline or other flammable vapors or liquids in the vicinity of this or any other appliance.

WHAT TO DO IF YOU SMELL GAS:

- Do not try to light any appliance
- Do not touch any electrical switch; do not use any phone in your building
- Immediately call your gas supplier from a neighbors phone.
- Follow the gas suppliers instructions
- If you can not reach your gas supplier, call the fire department

Installation and service must be performed by a qualified installer, service agency or the gas supplier.

English and French Installation Manuals available through your local dealer or visit our website at: www.archgard.com

Les manuels d'installation en anglais et en français son disponibles chez votre détaillant local ou en visitant notre site web: www.archgard.com

This appliance may be installed in an aftermarket permanently located, manufactured home (USA only) or mobile home where not prohibited by local codes.

This appliance is only for use with the type of gas indicated on the rating plate. This appliance is not convertible for use with other gases, unless a certified kit is used.

WARNING: If the information in these instructions is not followed exactly, a fire or explosion may result, causing property damage, personal injury or loss of life.

DANGER

HOT GLASS WILL CAUSE BURNS.

DO NOT TOUCH GLASS UNTIL COOLED.

NEVER ALLOW CHILDREN TO TOUCH GLASS.

A barrier designed to reduce the risk of burns from the hot viewing glass is provided with this appliance and must be installed for the protection of children and other at-risk individuals.

NATIONAL FIREPLACE INSTITUTE

CERTIFIED

www.nficertified.org

We recommend that our gas hearth products be installed and serviced by professionals who are certified in the U.S. by the National Fireplace Institute® (NFI) as NFI Gas Specialists.

INSTALLER: LEAVE THIS MANUAL WITH THE APPLIANCE.
CONSUMER: RETAIN THIS MANUAL FOR FUTURE REFERENCE.

ARCHGARD FIREPLACE PRODUCTS
 300 Railway Avenue
 Raymond, AB T0K 2S0 Canada

Canada

ENERGUIDE

Gas Fireplace Energy Efficiency Rating

76.95%

Based on CSA P.4.1-2015



200-1920-11
 March 11, 2026

TABLE OF CONTENTS

1.0 Introduction	3	14.0 Barrier Screen Installation	26
2.0 Safety Information	4	15.0 Glass Door Installation	27
3.0 Technical Information	5	15.1 If Your Glass Breaks.....	28
3.1 Appliance Certification.....	5	16.0 Surround Installation	29
3.2 Installation Codes.....	5	16.1 Dimensions of Surrounds.....	30
3.3 Specifications.....	5	16.2 Trimmable Surround Dimensions.....	31
3.4 High Altitude Installation.....	5	16.3 Dimensions of Fronts.....	32
4.0 Rating Plate	6	16.4 Dimensions of Decorative Trims.....	33
5.0 Installation Checklist	7	16.5 Dimensions of Decorative Plinths.....	34
6.0 Appliance Overview	8	16.6 Bottom Filler Plate.....	35
6.1 Appliance Overview.....	8	17.0 Firebox Liner Installation	36
6.2 Leveling the Appliance.....	8	17.1 Brick Panel Installation.....	36
6.3 Configuring the Controls.....	8	17.2 Reflective Glass Installation.....	38
6.4 Accessing the Control Board.....	9	18.0 Media Installation	40
6.5 Accessing the Gas Valve.....	9	18.1 Log Set.....	40
7.0 Electrical Connections	9	19.0 Operation	45
8.0 Appliance Dimensions	10	19.1 Before Lighting.....	45
8.1 Controls in Dimensions.....	10	19.2 First Fire.....	45
8.2 Controls out Dimensions.....	11	19.3 Lighting Instructions.....	46
9.0 Minimum Opening Dimensions	12	19.4 Dynamic Start Advantage.....	47
9.1 Factory Built Fireplaces.....	13	19.5 Remote Control Operation.....	48
9.2 Refacing a Masonry Fireplace.....	14	20.0 Maintenance	54
10.0 Clearances to Combustibles	15	20.1 Cleaning and Routine Maintenance.....	54
10.1 Mantel Clearances.....	15	20.2 Servicing Under Warranty.....	55
10.2 Minimum Sidewall Clearances.....	15	20.3 Checking Inlet and Outlet Pressure.....	55
10.3 Hearth Clearances.....	16	20.4 Checking and Adjusting Pilot.....	55
10.4 Heat Sensitive Flooring Materials.....	17	20.5 Adjusting the Primary Air.....	56
11.0 Gas Connections	18	20.6 Replacing Batteries.....	56
11.1 Clocking Procedure.....	18	20.7 Replacing Fuse.....	57
12.0 Conversion Kit Instructions	19	20.8 Replacing Light Bulbs.....	57
12.1 Prepare the Fireplace.....	19	20.9 Replacing the Control Board.....	58
12.2 Pilot Conversion.....	19	20.10 Removing the Intake Restrictor.....	59
12.3 Convert the Gas Valve.....	20	20.11 Removing the Burner.....	60
12.4 Complete the Conversion.....	20	20.12 Removing the Pilot.....	61
13.0 Venting Instructions	21	20.13 Replacing the Fan.....	64
13.1 Exhaust Restrictor.....	22	20.14 Replacing Light Bases.....	66
13.2 Approved Terminations.....	22	20.15 Wiring Schematic.....	68
13.3 Min/Max Vent Run.....	24	20.16 Troubleshooting.....	69
13.4 Using a Co-linear to Coaxial Adapter.....	25	21.0 Frequently Asked Questions	70
		22.0 Replacement Parts List	71

General Information

1.0 Introduction

Thank you and congratulations for choosing an Archgard Gas Fireplace insert!

Chantico (Chan-TEE-ko) - "she who dwells in the house" is the Aztec deity reigning over the fires in the family hearth. She was the goddess of pleasure and the home, the place where families gather. Ancient Aztecs prayed to Chantico to bestow wealth and stability upon their homes and men who were going off to battle would pray to her that they would return and find those home fires burning.

The Chantico 36 is one of the most advanced Direct Vent Insert heaters available today. It is solidly designed using the latest technology and manufactured to the highest quality. It is our aim to provide you with an appliance that brings many trouble-free years of reliable service. This manual provides information regarding model number 36-DVIE40LN-1.

Some of the many features of your **36-DVIE40LN-1** are:

- **Heater Classification** This fireplace is classified as a heating appliance. Therefore, it uses Direct Vent safety technology and it is suitable for continuously operated zone heating.
- **High Efficiency** This fireplace has one of the highest efficiencies of any Direct Vent gas insert, ensuring it is less expensive to operate.
- **Adjustable Fan Speed** This fireplace comes complete with an adjustable six speed circulation fan controlled with the remote.
- **Adjustable Flame** This fireplace provides the ability to adjust the flame aesthetics and heat output to suit the owner's liking and heating needs.
- **Adjustable Lighting** Use the included remote to choose from six levels of accent lighting or leave the light off and allow the flame to provide a flickering glow.
- **Solid Construction** This fireplace is mainly constructed of 16 and 18 gauge galvanized and aluminized coated steel for long life and durability.
- **Optional Accessories** Speak with your local Authorized Archgard Dealer for a full complement of decorative accessories to suit your home's decor and personal tastes.
- **Electronic Control System** This fireplace comes standard with the Dynamic Start Advantage. This new electronic ignition system is the latest in fireplace technology. It helps to create a better draft, better flame appearance, less condensation on the glass, and years of carefree operation. See **Section 19.4** for complete explanation of how the system works.
- **Multiple Electronic Pilot Settings** This fireplace uses a gas control valve that is operated by a Multifunction Remote Control. It can be set up as either an Intermittent Pilot Ignition (IPI) system, or Continuous Pilot on Demand Ignition (CPI) system (also known as a Pilot on Demand (POD)).

Model Number Definition (36-DVIE40LN-1)

36	Diagonal dimension of the fireplace opening in inches
DVI	Direct Vent Insert
E	Electronic Ignition
40	Natural Gas Input Rating in BTU
L	Traditional Log Set
N	Natural Gas
-1	Revision Number

CPI vs IPI:

Continuous Pilot on Demand Ignition (CPI): In this mode the pilot runs continuously even when the main burner is off. The Continuous Pilot on Demand Ignition operates on a seven day cycle. If the main burner is not turned on for seven continuous days, the pilot will turn itself off. When the main burner is lit again the cycle repeats. The pilot will remain lit for seven days, even after the main burner is turned off. If the main burner is lit during a seven day timing cycle, the seven day timer will reset.

Intermittent Pilot Ignition (IPI): A fuel saving mode in which the pilot is only used when the main burner is on.

This appliance is shipped in IPI mode. IPI mode is often the preferred method, however, there are some situations where it may be preferable to switch the fireplace into CPI mode. For example, in colder climates the glass door or the front of the fireplace could become very cold to the touch. Dynamic Start Advantage will solve most problems experienced by older IPI operated fireplaces.

Please complete and submit the warranty registration card included in the back of this manual or by visiting us at:
www.archgard.com/warranty-registration



General Information

2.0 Safety Information

Caution

FOR YOUR SAFETY - Do not install or operate your **36-DVIE40LN-1** without reading and understanding this manual. Any installation or operational deviation from this instruction manual voids the warranty and may prove hazardous.

- This appliance must be installed by a qualified gas installer and the installation must conform to the installation codes
- Provide adequate clearance around air openings into combustion chamber
- Never obstruct front openings
- Provide adequate clearances for proper operation and servicing of the appliance
- This appliance must be properly connected to an approved venting system and must not be connected to a chimney flue serving a separate solid fuel burning appliance
- Flow of combustion and ventilation air must not be obstructed - always provide adequate combustion and ventilation air
- Always provide adequate clearance around the intake and exhaust openings

Safety

- Due to high temperatures, the appliance should be located out of traffic and away from furniture and draperies
- Children and adults should be alerted to the hazards of high surface temperature and stay away to avoid burns or clothing ignition
- If this appliance is installed directly on carpeting, tile, or other combustible material other than wood flooring, the appliance shall be installed on a metal or wood panel extending the full width and depth of the appliance
- Young children should be carefully supervised when they are in the same room as the appliance. Toddlers, young children and others may be susceptible to accidental contact burns. A physical barrier is recommended if there are at risk individuals in the house. To restrict access to a fireplace or stove, install an adjustable safety gate to keep toddlers, young children and other at risk individuals out of the room and away from hot surfaces
- Do not store or place combustibles, gasoline, and other flammable vapors and liquids near the appliance
- Clothing or other flammable material should not be placed on or near the appliance
- **WARNING:** Do not operate appliance with the glass front removed, cracked, or broken. Removal of the glass should be done by a licensed or qualified service person. Do not to strike or slam the glass
- Any safety screen or guard removed for servicing an appliance must be replaced prior to operating
- Installation and Repair should be done by a qualified service person. The appliance should be inspected before use and at least annually by a professional service person. More frequent cleaning may be required due to excessive lint from carpeting, bedding materials, etc. It is imperative that the control compartments, burners and circulating air passageways of the appliance are kept clean
- Under no circumstances should any solid fuel (wood, coal, paper or cardboard, etc.) be used in this appliance
- Keep burner and control compartment clean
- Do not use this appliance if any part has been under water. Immediately call a qualified service technician to inspect the appliance and to replace any part of the control system and any gas control which has been under water
- **California Proposition 65 Warning:** This product can expose you to chemicals including Carbon Monoxide, that is an externally vented by-product of fuel combustion, which is [are] known to the State of California to cause cancer, birth defects, or other reproductive harm. For more information, visit www.P65Warnings.ca.gov

Each Archgard Gas Fireplace is checked and tested at the factory prior to being packaged and shipped to our dealers and finally installed in your home. Before leaving this unit with the customer, the installer must ensure that the appliance is firing correctly and that the electrical system is in working order. The Installation Checklist in **Section 5.0** should be used to ensure the proper installation of this gas fireplace heater and to document any deviations from a typical install.

Any alteration to the product that causes carbon or soot deposits that results in any damage or requires cleaning is not the responsibility of the manufacturer.

General Information

3.0 Technical Information

3.1 Appliance Certification

This appliance was listed by QAI Laboratory Inc to the following USA and Canadian gas appliance standards.

- ANSI Z21.88-2019 / CSA 2.33-2019 Vented Gas Fireplace Heaters
 - CAN/CGA-2.17-M91 (R2014), Gas-Fired Appliances for Use at High Altitudes
 - CSA P.4.1-2015 testing method for measuring annual fireplace efficiency
 - CSA C22.2 No.3 - M1998(R.2014) - Electrical Features of Fuel-Burning Equipment
- The listing label is attached to the appliance on the bottom right side of the appliance.
A copy is shown on **Section 4.0**.

Commonwealth of Massachusetts: This appliance has been manufactured in accordance with Massachusetts code 248 CMR 5.00. Approval Code: **G1-0717-621**. (<http://license.reg.state.ma.us/public/licque.asp>).

Please contact **Archgard Industries Ltd.**, if you have any questions regarding the certification of this appliance.

3.2 Installation Codes

This appliance must be installed by a qualified gas appliance installer. The installation must conform with the local codes or, in the absence of local codes, with the current National Fuel Gas Code ANSI Z223.1/ NFPA 54 in the US, or Installation Code CAN/CGA-B149.1 in Canada. Electrical connections and grounding must conform with local code, or current National Electrical code ANSI/NFPA No. 70-1987 in the US, and in Canada the current Canadian Electrical Code CSA C22.1.

This appliance is certified for installation in a bedroom or a bed sitting room. Please refer to local codes for thermostat requirements.

We recommend that our gas hearth products be installed and serviced by professionals who are certified in the U.S. by the National Fireplace Institute® (NFI) as NFI Gas Specialists.

3.3 Specifications

	Natural Gas (NG)	Propane (LP)
Manifold Pressure	1.1 - 3.8 in. W.C. (0.27 - 0.95 kPa)	2.9 - 11 in. W.C. (0.72 - 2.74 kPa)
Min. Supply Pressure	5 in. W.C. (1.2 kPa)	12 in. W.C. (2.9 kPa)
Max Supply Pressure	14 in. W.C. (3.5 kPa)	14 in. W.C. (3.5 kPa)
Orifice Size	#30 DMS (3.26 mm)	#48 DMS (1.93 mm)
Input Rating	22,000 - 40,000 BTU/h (6.45 - 11.72 kWh)	20,000 - 40,000 BTU/h (5.86 - 11.72 kWh)
P.4 Fireplace Efficiency (FE)	76.95%	
P.4 Steady State Efficiency	79.10%	
Electrical Rating	120 VAC, 60Hz less than 2 A.	
Gas Control	SIT 885 Proflame II Dynamic Start Advantage with Continuous Pilot on Demand	
Altitude	0 - 4,500 ft. (0 - 1,372 M)	
Primary Air Opening	1/16" (1.6 mm) Open	100% Open

3.4 High Altitude Installation

When installing this appliance beyond 4500 ft. (1372 M) above sea level, the appliance must be properly derated and installed according to local codes, in the absence of local codes, with the current National Fuel Gas Code, ANSI Z223.1/ NFPA 54, in the US or Installation Code, CAN/CGA-B149.1, in Canada.

General Information

4.0 Rating Plate

DO NOT REMOVE THIS LABEL



MODEL: 36-DVIE40LN-1 (SIT 885 Proflame)

LISTED VENTED GAS FIREPLACE HEATER and GAS-FIRED APPLIANCES FOR USE AT HIGH ALTITUDES. Tested to: ANSI Z21.88-2019 / CSA 2.33-2019 and CAN/CGA-2.17-M91 (R2014), CSA P.4.1-2015 - Testing Method for Measuring Annual Fireplace Efficiency, CSA C22.2 No.3 - M1998(R.2014) - Electrical Features of Fuel-Burning Equipment. This vented gas fireplace heater is not for use with air filters. Certified for use in both CANADA and USA.

VENTED GAS FIREPLACE HEATER-NOT FOR USE WITH SOLID FUEL.

	NG	LPG
Input rating	22,000 - 40,000 BTU/hr (6.45 - 11.72 kW)	20,000 - 40,000 BTU/hr (5.86 - 11.72 kW)
Manifold Pressure	1.1 - 3.8 in. W.C. (0.72 - 0.95 kPa)	2.9 - 11.0 in. W.C. (0.72 - 2.74 kPa)
Orifice size	#30 DMS (3.26 mm dia.)	#48 DMS (1.93 mm dia.)
Supply pressure (Min - Max)	5.0 - 14.0 in. W.C. (1.2 - 3.5 kPa)	12.0 - 14.0 in. W.C. (2.9 - 3.5 kPa)
Burner Primary Air Setting	100% Open	100% Open
Altitude	0 - 4500 ft (0 - 1372 m)	0 - 4500 ft (0 - 1372 m)
Gas Control	SIT 885 Proflame II Dynamic Start with Continuous POD	
Electrical rating	120 VAC, 60 Hz less than 2 A.	
P.4.1 Fireplace Efficiency (FE)	76.95%	
Replacement fan	RF-305-0024	
Keep burner and control ports clean. See Instructions accompanying the heater. Optional fuel conversion kit available. See Manual	Minimum opening Dimensions: 37.875"(962 mm)W x 24"(610 mm)H x 18.5"(469.9 mm)D Minimum Chimney Flue Size: 4" (100 mm) x 7" (176 mm) Minimum clearances to Combustibles: Sides from glass door frame: 8" (203.2 mm) Mantle: max 12" (305 mm) at min 20" (508 mm) from top of appliance door See Manual for additional dimensions and clearances	

This appliance must be installed in accordance with local codes, if any; if none, follow the National Fuel Gas Code, ANSI Z223.1/NFPA 54, or Natural Gas and Propane Installation Codes, CSA B149.1. Electrical connections and grounding must be in accordance with local codes, if any; if none, follow the current CAN/CSA C22.1 in Canada and ANSI/NFPA 70 in the US. This appliance is certified for installation in a bedroom or a bed sitting room. This appliance is only for use with the gas indicated on the rating plate and may be installed in an aftermarket, permanently located, manufactured (mobile) home where not prohibited by local codes. See owner's manual for details. This appliance is not convertible with other gases, unless a certified kit is used.

WARNING: Improper installation, adjustment, alteration, service, or maintenance can cause injury or property damage. Refer to the owner's information manual provided with this appliance. For assistance or additional information consult a qualified installer, service agency, or the gas supplier. This appliance must be properly connected to a Direct Vent venting system in accordance with the manufacturer's installation instructions.

WARNING: Failure to install this appliance per the manufacturer's instructions or failure to use only parts specifically approved with this appliance may result in property damage or personal injury.

WARNING: Do not operate the appliance until all sections have been assembled and installed in accordance with the manufacturer's instructions.



WARNING: Operation of this appliance when not connected to a properly installed and maintained venting system can result in carbon monoxide (CO) poisoning and possible death.

ONLY DOORS CERTIFIED WITH THE APPLIANCE SHALL BE USED.
For use only with barrier part # 36-BS. Follow installation instructions.

Made in Canada by:
Archgard Industries Ltd.
300 Railway Avenue,
Raymond, AB T0K 2S0
Canada

October 2024 303-6400-05

MANUFACTURE DATE:	
-------------------	--

Installation

5.0 Installation Checklist

This standard installation checklist is to be used by the installer in conjunction with, not instead of, the instructions contained within this installation manual.

Customer: _____ Install Address: _____	Date Installed: _____ Location of Fireplace: _____ Installer: _____
---	--

Solid Fuel Zero Clearance Install: (Section 9.1)	YES	NO	IF NO, WHY NOT?
Was the bottom of the existing zero clearance firebox removed?			
Was a 0.15" (3.8 mm) minimum clearance maintained as shown in Figure 9.1.02 ?			
Venting: (Section 13.0)	YES	NO	IF NO, WHY NOT?
Venting configuration complies with vent diagrams.			
Venting installed, fastened, and secured in place maintaining proper clearances.			
Secured or removed existing solid fuel fireplace damper.			
Terminations installed and sealed in compliance with local building code.			
Direct vent termination is highest point in vent assembly.			
Wiring / Electrical: (Section 7.0)	YES	NO	IF NO, WHY NOT?
Connected to household 110/120v per local codes.			
Unit is properly grounded.			
Gas: (Section 11.0)	YES	NO	IF NO, WHY NOT?
Proper appliance for fuel type?			
Was a conversion performed?			
Leak check performed & inlet and manifold pressures verified?			
Was the rating of the insert clocked?			
Finishing:	YES	NO	IF NO, WHY NOT?
Only noncombustible material installed in noncombustible areas.			
Clearances meet installation manual requirements.			
Mantels and/or projections comply with install manual.			
Was the solid fuel fireplace warning plate installed (Figure 9.0.02)?			
Appliance Setup:	YES	NO	IF NO, WHY NOT?
Log set, door, and screen installed according to install manual.			
Manual given to home owner.			
Did you check operation of lights, fans, and flame modulation?			
Does the main burner light within 4 seconds of main gas valve opening (see Section 20.1)?			
Door buckles operate freely?			

6.0 Appliance Overview

6.1 Appliance Overview

The Proflame II control board is located on the right side* of the fireplace behind the surround.

The valve is located on the left side* of the fireplace behind the surround.

The fan is located on the inside of the rear fireplace shell and can be accessed from the rear of the fireplace or from the front by removing the burner.

Note: This manual uses images of an unpainted fireplace for the purposes of illustration.

*Left and right side references in this manual correspond with the sides identified in **Figure 6.1.01**.

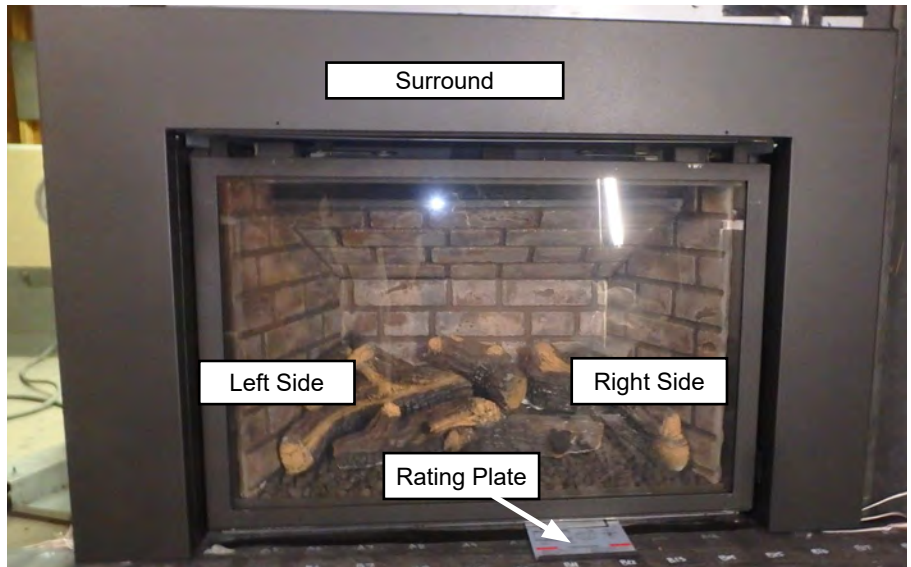

Figure 6.1.01:

6.2 Leveling the Appliance

The 36-DVIE40LN-1 is equipped with front and rear leveling bolts. The fireplace has the ability to independently level left/right and front/back.

Leveling is done from the bottom of the unit

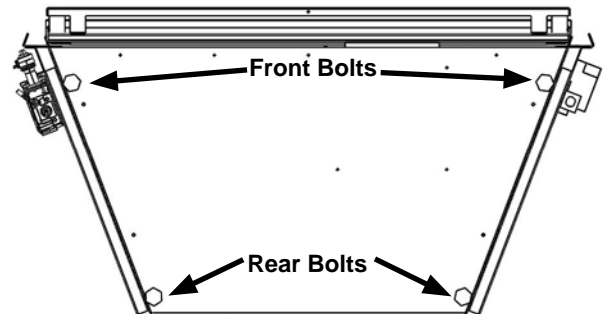

Figure 6.2.01:

6.3 Configuring the Controls

The controls on the 36-DVIE40LN-1 may be relocated to allow for installation in most larger masonry fireplace openings. To relocate the controls, remove the (3) tek screws securing each control panel and reattach in the configuration of your choosing.

Each fireplace ships in the "Controls In" position.

Note: Be sure to check the installation opening dimensions to choose the appropriate trim for your install. The deep trim is required when converting to a "Controls Out" installation.

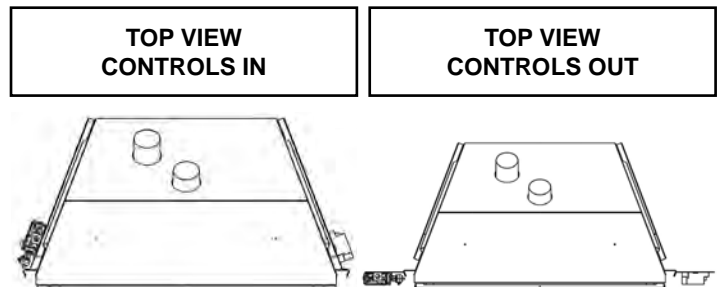

Figure 6.3.01:

Installation

6.4 Accessing the Control Board

The control board is located on the right side of the fireplace, behind the fireplace surround (see **Section 6.1**). To access the control board:

1. Ensure the fireplace is off and cool.
2. Disconnect power supply.
3. Remove Fireplace Surround.

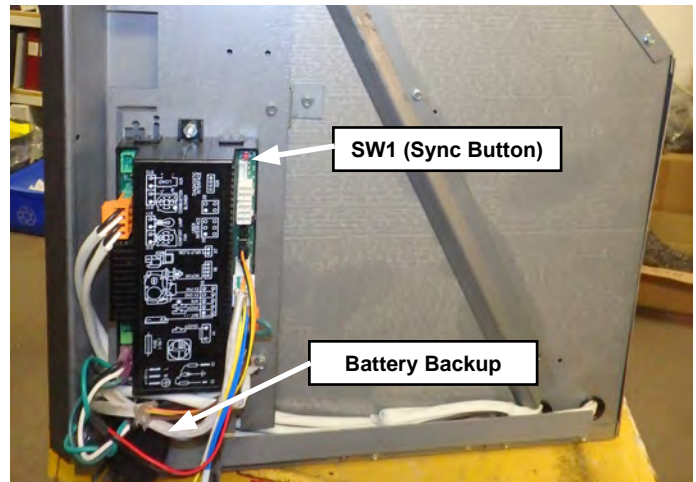

Figure 6.4.01:

6.5 Accessing the Gas Valve

The valve is located on the left side of the fireplace, behind the fireplace surround (see **Section 6.1**). To access the valve:

1. Ensure the fireplace is off and cool.
2. Disconnect power supply.
3. Remove Fireplace Surround.

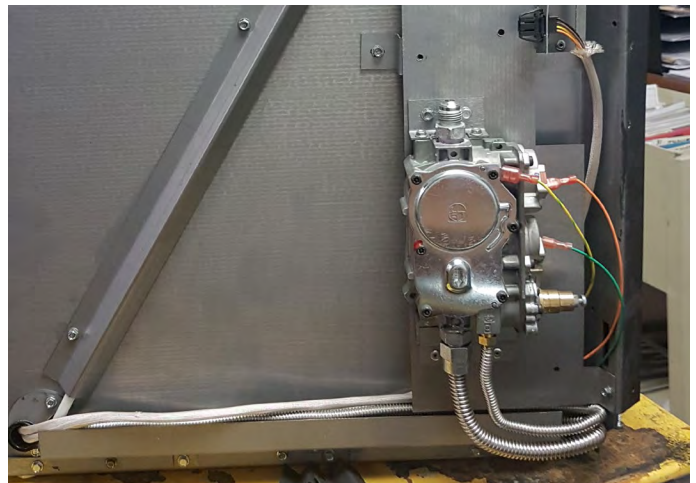

Figure 6.4.01:

7.0 Electrical Connections

The **36-DVIE40LN-1** comes complete with an adjustable 6 speed fan and variable lights wired directly to the main control module.

Do not cut or remove the grounding prong from the main power supply plug.

CAUTION: Label all wires prior to disconnection when servicing.

NOTE: This appliance, when installed, must be electrically grounded in accordance with local codes or, in the absence of local codes, with the National Electrical Code, ANSI / NFPA 70, or the Canadian Electrical code, CSA C22.1.

Installation

8.0 Appliance Dimensions

8.1 Controls in Dimensions

Dimensions shown are in inches.
use Shallow Trim

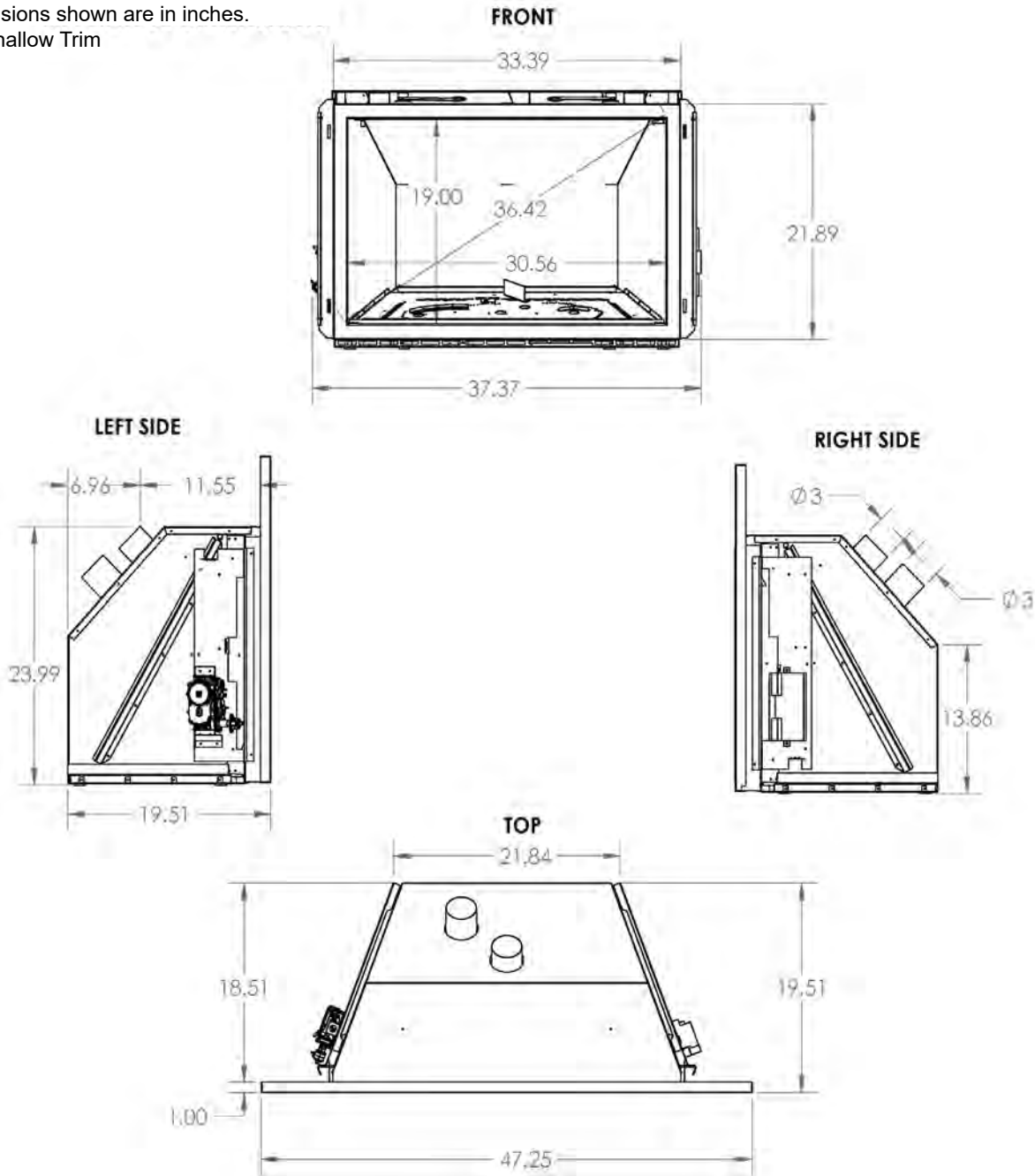

Metric Equivalents

	Inches	mm	Inches	mm	Inches	mm	Inches	mm	Inches	mm	Inches	mm
FRONT	33.39	848.11	21.89	556.01	37.37	949.2	30.56	776.22	36.42	925.07	19.00	482.6
TOP	21.84	554.74	18.51	470.15	19.51	495.55	1.00	25.4	47.25	1200.15		
LEFT SIDE	6.96	176.78	11.55	293.37	23.99	609.35	19.51	495.55				
RIGHT SIDE	3	76.2	3	76.2	13.86	352.04						

Installation

8.2 Controls out Dimensions

Dimensions shown are in inches.
Use Deep Trim.

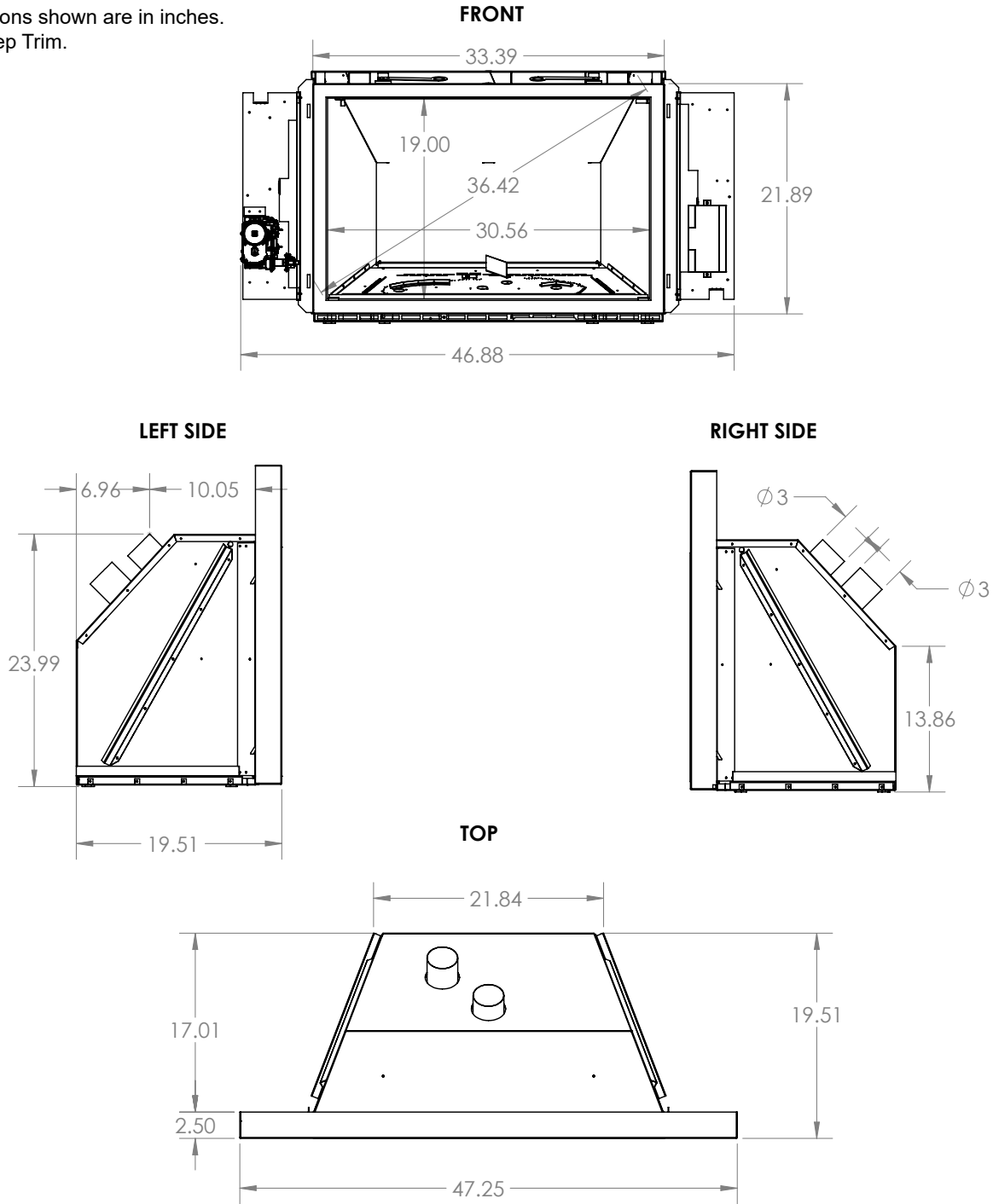

Metric Equivalents												
	Inches	mm	Inches	mm	Inches	mm	Inches	mm	Inches	mm	Inches	mm
FRONT	33.39	848.11	21.89	556.01	46.88	1190.75	30.56	775.22	36.42	925.07	19.00	482.6
TOP	21.84	554.74	17.01	432.05	19.51	495.55	2.50	63.5	47.25	1200.15		
LEFT SIDE	6.96	176.78	10.05	255.27	23.99	609.35	19.51	495.55				
RIGHT SIDE	3	76.2	3	76.2	13.86	352.04						

9.0 Minimum Opening Dimensions

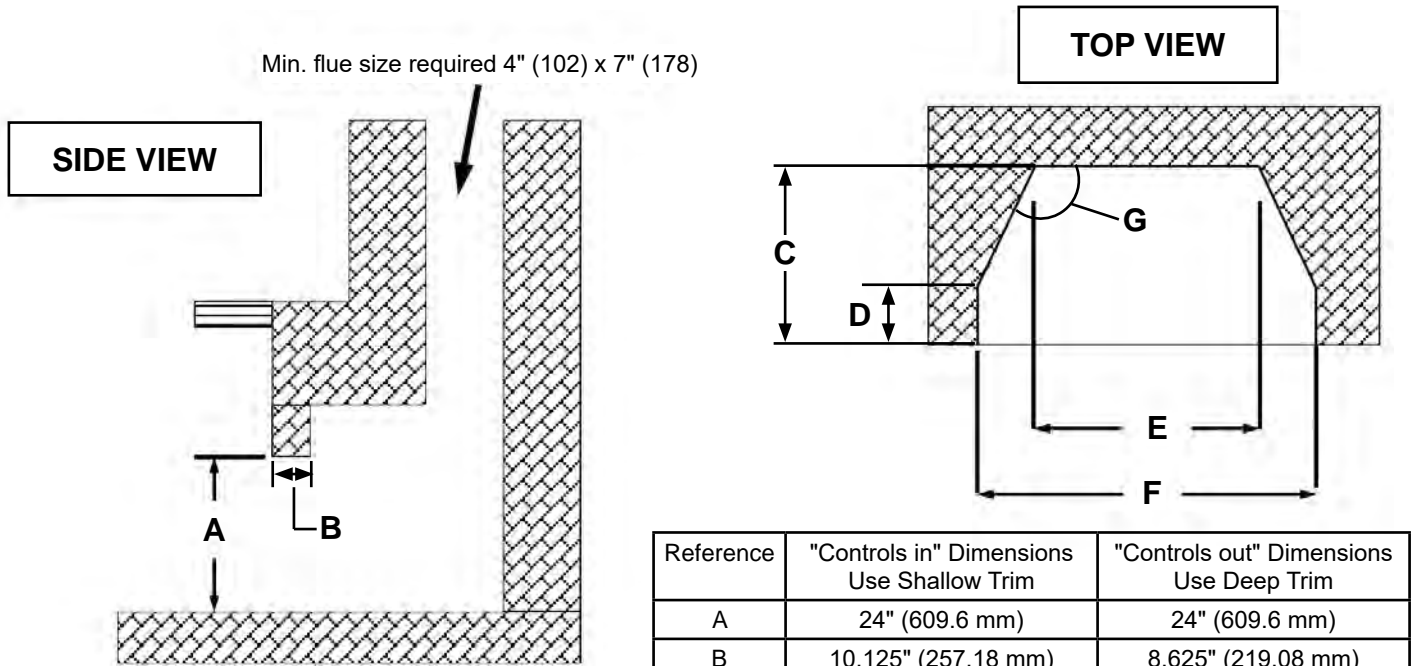

Figure 9.0.01:

WARNING: Failure to position the parts in accordance with these diagrams or failure to use only parts specifically approved with this appliance may result in property damage or personal injury.

Reference	"Controls in" Dimensions Use Shallow Trim	"Controls out" Dimensions Use Deep Trim
A	24" (609.6 mm)	24" (609.6 mm)
B	10.125" (257.18 mm)	8.625" (219.08 mm)
C	18.5" (469.9 mm)	17" (431.8 mm)
D	3.75" (95.25 mm)	0" (0.00 mm)
E	26.5" (673.1 mm) to 21.875" (555.63 mm)*	21.875" (555.63 mm)
F	37.875" (962.03 mm)	36.25" (920.75 mm)
G	111°	113°

*Dimension E may be smaller than 26.5" (673.1 mm) if the depth (dimension C and/or D) is larger.

The installer must mechanically attach the marking supplied with the gas fireplace insert to the inside of the firebox of the fireplace into which the gas fireplace insert is installed. See **Figure 9.0.02**.

WARNING: This fireplace has been converted for use with a gas fireplace insert only and cannot be used for burning wood or solid fuels, unless all original parts have been replaced, and the fireplace reapproved by the authority having jurisdiction.

AVERTISSEMENT: Ce foyer a ete converti pour utilisation avec un foyer au gaz encastrable et ne peut etre utiliser pour bruler du bois ou autres combustibles solides a moins que toutes les pieces d'origine ete remplacees et que le foyer ait ete approuve de nouveau par l'autorite competente.

303-0123

Figure 9.0.02:

Cutting of any sheet-metal parts of the fireplace, in which the gas fireplace insert is to be installed, is prohibited except as described in **Section 9.1**.

The fireplace flue damper can be fully blocked open or removed for installation of the gas fireplace insert. The fireplace and fireplace chimney must be clean and in good working order and constructed of noncombustible materials. The chimney clean-outs must fit properly.

Installation

9.1 Factory Built Fireplaces

The following information applies to **Factory Built (metal) Wood-Burning Fireplace** installations:

Trim panels must not seal ventilation openings in the fireplace. Any parts that are removed must be saved and reinstalled if the insert is ever removed. If the factory-built fireplace has no gas access hole(s) provided, an access hole of 1 1/2" (38.1 mm) or less may be drilled through the lower sides or bottom of the firebox in a proper workmanship-like manner. This access hole must be plugged with noncombustible insulation after the gas supply line has been installed.

The damper (A) and grate with logset (B) must be removed or fully blocked open.

The smoke shelf (C), internal baffles (D), screen (E), masonry lining or refractory (G and I), and metal or glass doors (F) may be removed.

The fireplace must be permanently marked to indicate that it has been altered and is no longer suitable for burning any fuel unless the removed parts are reinstalled (See **Figure 9.0.02**). Cutting out of any metal parts is prohibited, except the metal floor (J) as specified.

The insulation (H), and any structured rigid frame member must not be removed or altered (side and top of door frame, side and top of the face of fireplace, metal sides, etc.).

The metal floor of the firebox may be removed only if the following is strictly adhered to.

The metal floor (J) may be removed to allow additional room for installation of the insert as long as it does not compromise the structural integrity of the existing fireplace and you maintain a mandatory minimum 0.15" (3.8 mm) clearance between the bottom of the insert and the bottom shell of the existing fireplace. This may be achieved by using strips of noncombustible material or by using leveling bolts on the insert (See **Figure 9.1.02**). If the floor is removed the insert must be placed directly on the metal base of the metal fireplace. **Under no circumstance can it be placed directly on a combustible material.**

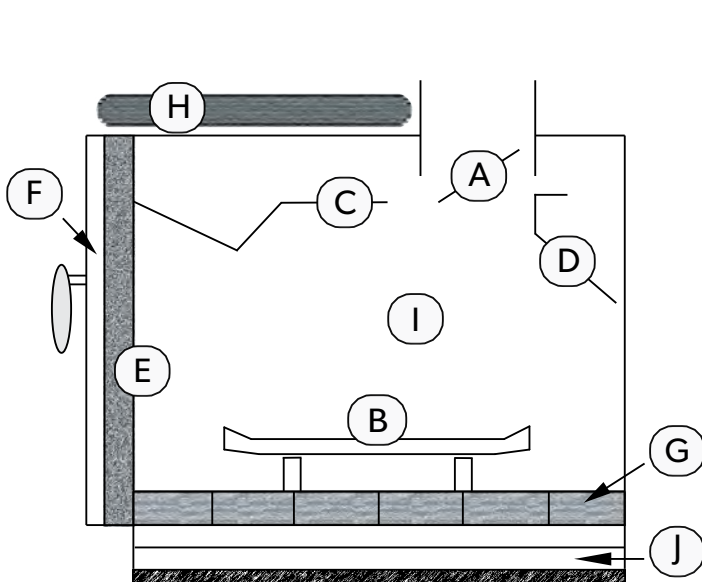

Figure 9.1.01: Side view of Factory Built (metal) Wood Burning Fireplace.

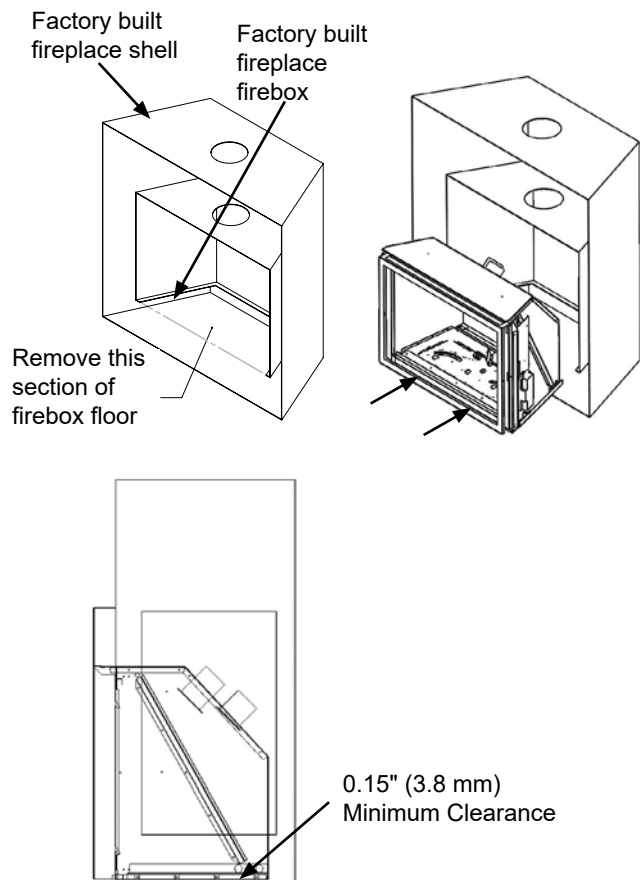

Figure 9.1.02: Removing the Metal Floor

Installation

9.2 Refacing a Masonry Fireplace

Using Steel Studs and Cement Board on Wood Fireplaces

Brick or rock facing may be removed and replaced with noncombustible material such as steel studs and cement board.

WARNING: Only facing material may be removed. All other masonry material must not be cut out, chipped away, or removed.

WARNING: Louvers or any air circulation around existing solid fuel fireplace must not be blocked or covered.

The area between the masonry and the cement board must be sealed so that no heat can enter the open space between the masonry of the wood fireplace and the refacing material. **The insert must be moved outward so that the face of the fireplace is flush with the finishing material.**

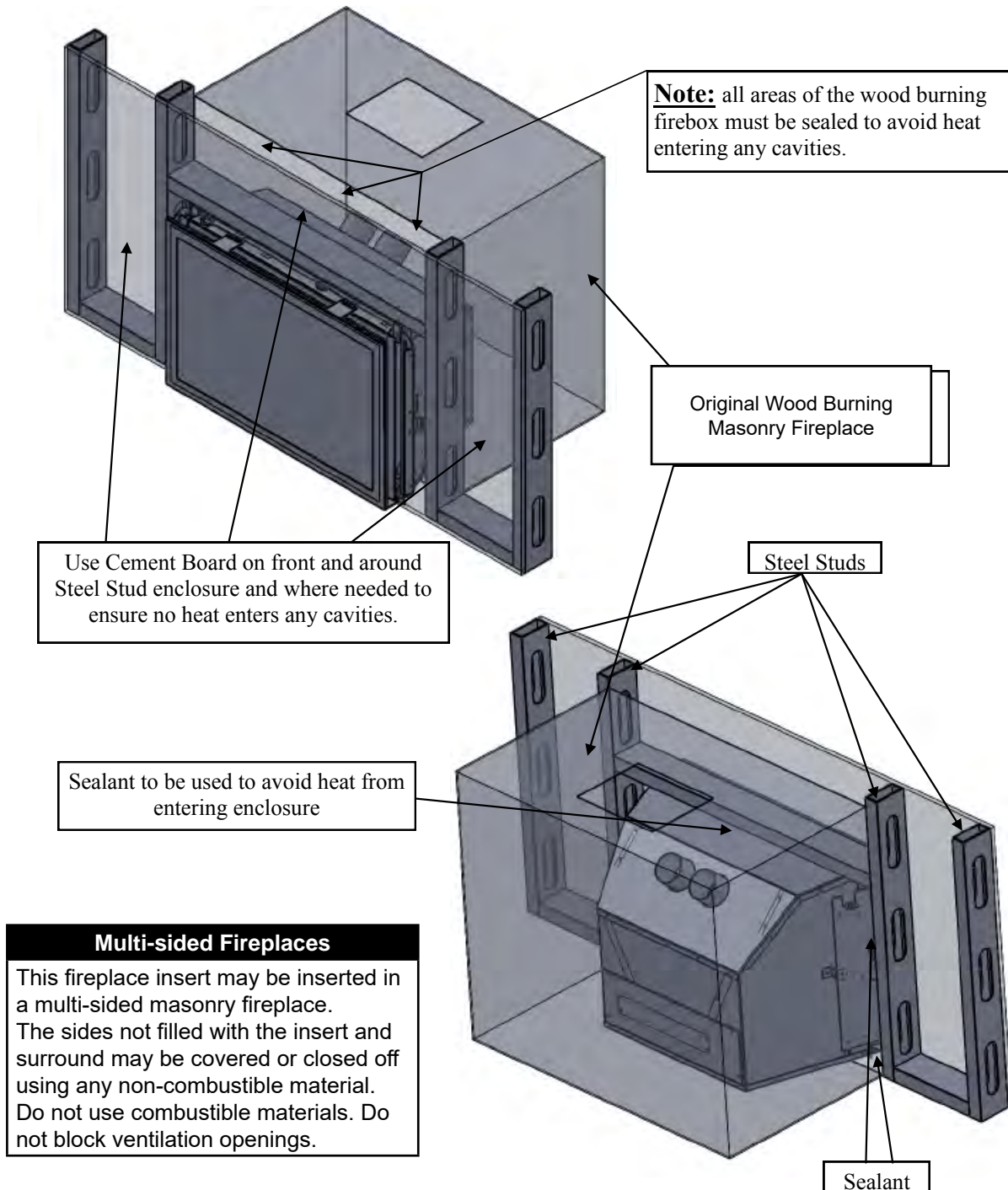

Figure 9.2.01:

Installation

10.0 Clearances to Combustibles

WARNING: Failure to position the parts in accordance with these diagrams or failure to use only parts specifically approved with this appliance may result in property damage or personal injury or loss of life.

CAUTION: This appliance is designed for use in any masonry or factory-built, wood-burning fireplace. It cannot be enclosed by combustible material and used as a factory built gas fireplace (zero clearance fireplace).

10.1 Mantel Clearances

Mantel clearances are measured from the top of the appliance door. Ensure combustible material is not placed within the area shown.

Ceiling clearance: 48" (1219.2 mm)
from the top of the appliance door.

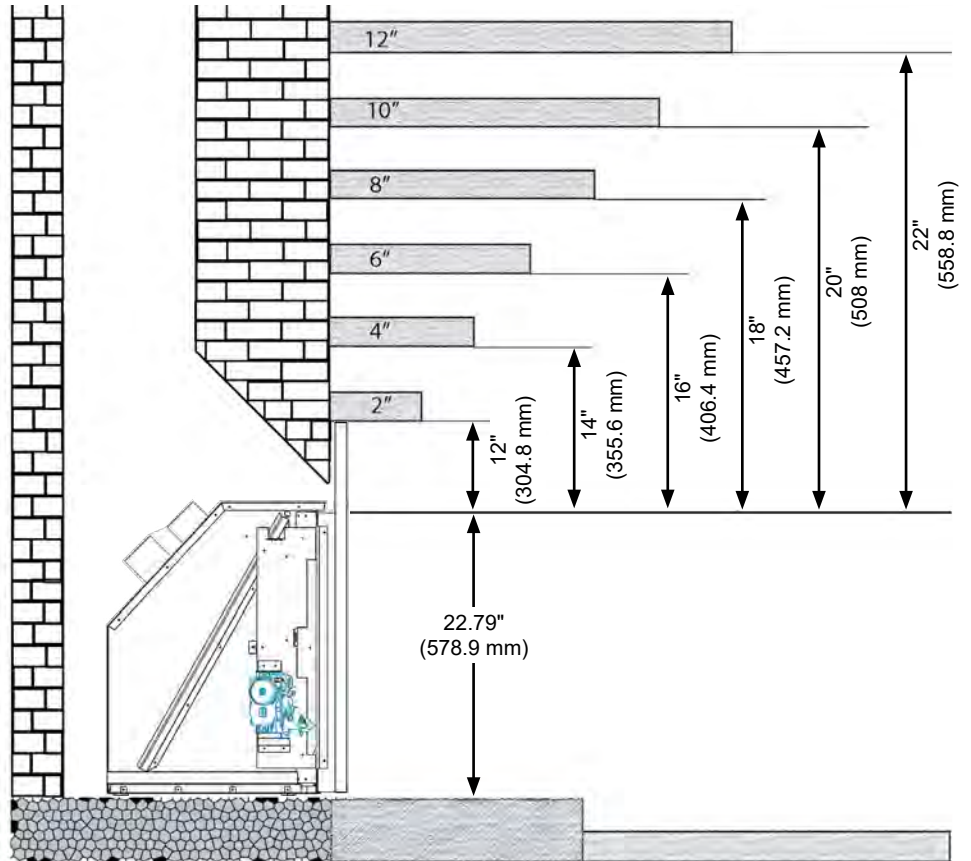

Figure 10.1.01

10.2 Minimum Sidewall Clearances

Maintain a minimum of 8" (203.2 mm) clearance from the side of the door to sidewalls or mantel supports.

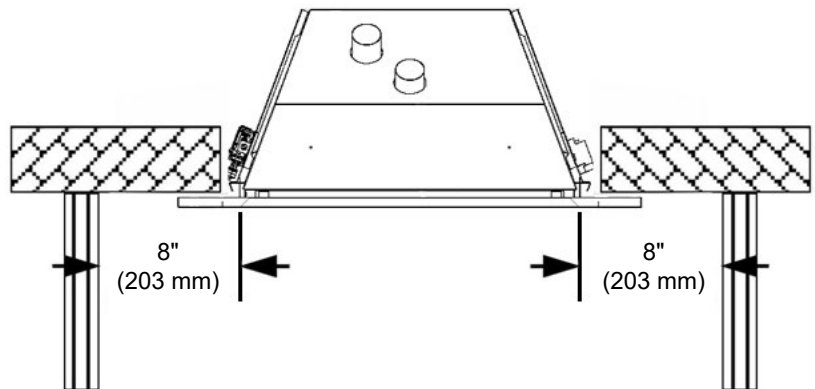

Figure 10.2.01

Installation

10.3 Hearth Clearances

WARNING

Failure to position the parts in accordance with these diagrams or failure to use only parts specifically approved with this appliance may result in property damage or personal injury.

Any hearth that extends outward in front of the insert must not have any combustible material closer than 9" (228.6 mm) to the bottom of the gas fireplace insert regardless of whether a noncombustible material covers the combustible material. This includes any type of framing underneath a noncombustible material such as tile, marble, or stone. Any material farther than 9" (228.6 mm) to the bottom or 16" (406.4 mm) from the front of the masonry opening of the existing fireplace can be combustible.

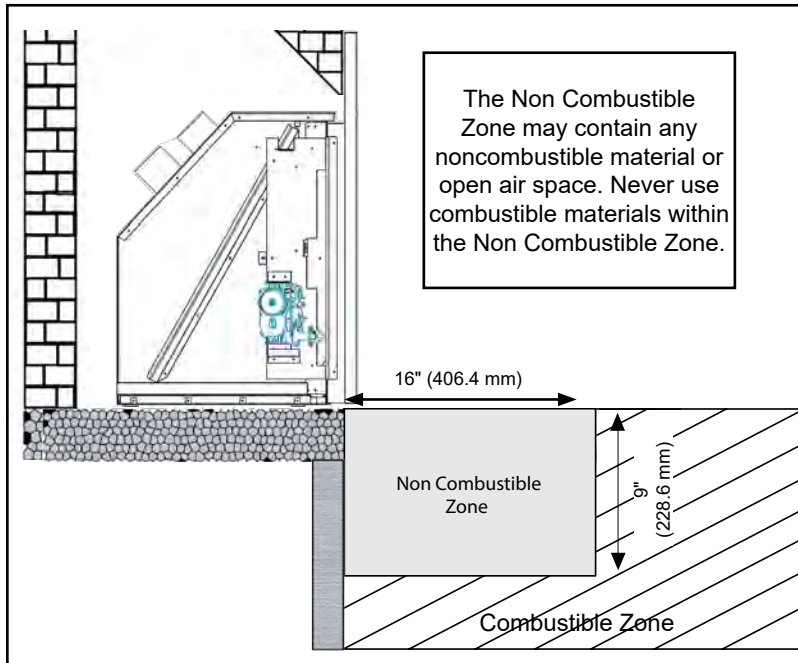

Figure 10.3.01

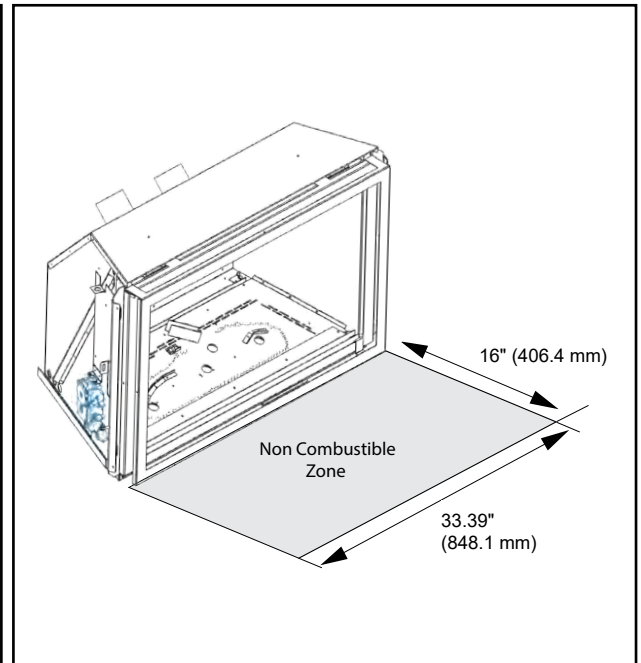

Figure 10.3.02

NOTE

All specified clearances must be maintained from the top surface of carpeting, tile, etc.

Installation

10.4 Heat Sensitive Flooring Materials

Archgard fireplaces are heating products, designed to produce a large amount of radiant and convective heat. The clearances specified above are intended to be minimum clearance distances to combustible materials, however, flooring directly adjacent to the minimum hearth clearances may reach temperatures of up to 180°F (82°C) or higher depending on the installation.

Please check with your flooring manufacturer for temperature tolerances as some materials, such as vinyl, tend to be more sensitive to temperatures above average room temperature and may be damaged or warped if exposed to heat.

We recommend testing any flooring material to ensure that it can withstand temperatures generated by this fireplace. If the tolerances of the flooring material are not known or are not capable of withstanding the temperatures generated by this fireplace, install a heat pad constructed of material that is not sensitive to heat, or adjust clearances to heat sensitive materials as shown below.

Note: clearances shown are the width of the fireplace door. The dimensions shown are guidelines only and cannot account for all flooring materials. The dimensions shown do not replace the hearth clearances for this product. Always maintain the clearances to combustible materials as shown on the previous page.

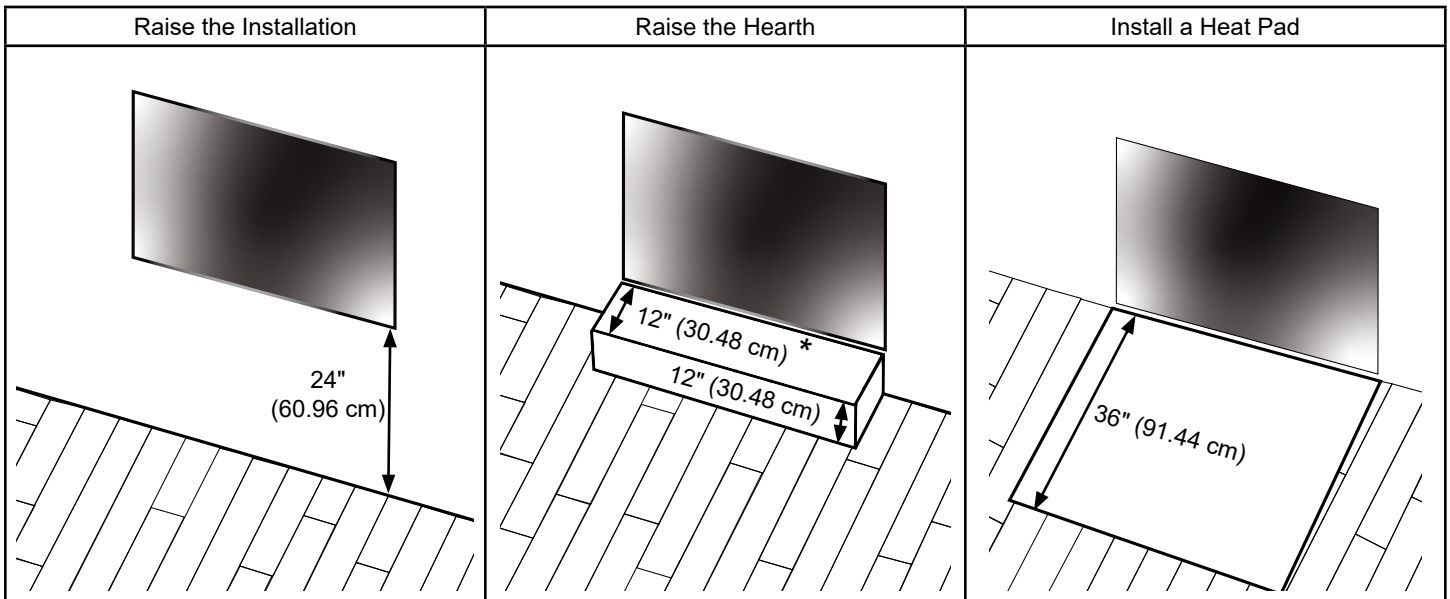

Figure 10.4.01

* Use whichever distance is greater when compared to the hearth clearances.

Installation

11.0 Gas Connections

Before connecting the appliance to the gas supply line, double check that the appliance you have purchased is designed for the gas type you are using. The gas type markings are located on the rating plate (See **Section 4.0** and **Section 6.1**) and also on the appliance's gas valve.

Adequate clearance for proper installation and checking of the gas connections must be provided. **All gas connections must be checked for gas leaks.**

Have your gas supplier or a qualified gas fitter run a gas supply line into the solid fuel fireplace. The line must be properly sized and fitted according to the installation codes. Immediately upstream of the supply connection, the fitter shall provide an accessible manual shut-off valve. When connecting the supply line to the gas valve, the installer shall brace the gas valve to ensure that the gas valve is not moved from its bracket. If the valve is not braced when the supply line is connected, the valve may be moved and cause a "break" in the main burner supply line. Such damage is not covered by the manufacturer's warranty.

CAUTION: The appliance and its individual shut-off valve must be disconnected from the gas supply piping system during any pressure-testing of that system at test pressures in excess of 1/2 psig (3.5 kPa). The appliance must be isolated from the gas supply piping system by closing its individual manual shut-off valve during any pressure-testing of the gas supply piping system at test pressures equal to or less than 1/2 psig (3.5 kPa). Failure to do so will damage the appliance's gas valve. Such damage is not covered by the manufacturer's warranty.

Natural Gas Pressure Settings:

The inlet supply or line pressure must be a minimum of 5.0" W.C. (1.2 kPa) and a maximum of 14.0" W.C. (3.5 kPa). The orifice is a #30 DMS (3.26 mm) drill size.

<u>ELEVATION</u>	<u>INPUT RATING</u>
0-4500 ft (0-1372 M)	40,000 BTU/hr (11.72 kW)
4500 ft (1372 M) and above.	40,000 BTU/hr (11.72 kW) less 4% per 1000 ft. (305 M) above sea level.

Please contact your local distributor for the appropriate orifice size you require.

Propane Pressure Settings:

The inlet supply or line pressure must be a minimum of 12.0" W.C. (2.9 kPa) and a maximum of 14.0" W.C. (3.5 kPa). The orifice is a #48 DMS (1.93 mm) drill size.

<u>ELEVATION</u>	<u>INPUT RATING</u>
0-4500 ft. (0-1372 M)	40,000 BTU/hr (11.72 kW)
4500 ft. (1372 M) and above.	40,000 BTU/hr (11.72 kW) less 4% per 1000 ft. (305 M) above sea level.

Please contact your local distributor for the appropriate orifice size you require.

11.1 Clocking Procedure

IMPORTANT: THE INPUT RATING SHOULD ALWAYS BE CHECKED WHEN FIRST FIRING THIS APPLIANCE.

Before you begin, shut off all other gas appliances including any continuous / standing pilots. Light the fireplace and wait 15 minutes. Clock the time to burn 1ft³ of gas on the meter. Check with your gas supplier for the gas BTU content at your elevation. Input is the rate of flow multiplied by the heating value of the gas (cubic feet/hour x BTU per cubic feet). **Note:** This assumes a dry gas meter at 1/2 psi. If using a 2 psi dry gas meter the unit will rate lower as the calculation has to correct for the higher pressure in the meter. If the unit is over-rated, contact your authorized Archgard dealer. The following calculation equation gives a rough estimation as it does not correct for temperature and pressure.

Rough Calculation Equation:

$$\frac{3600}{\text{time to burn 1ft}^3 \text{ gas in seconds}} \times \frac{\text{gas calorific value}}{\text{in BTU/ft}^3} = \text{Rating in } \frac{\text{BTU}}{\text{hr}}$$

Installation

12.0 Conversion Kit Instructions

IMPORTANT: This fireplace is Natural gas ready. If converting to LP gas, follow instructions below.

WARNING: This conversion kit shall be installed by a qualified service agency in accordance with the manufacturers instructions and all applicable codes and requirements of the authority having jurisdiction. If the information in these instructions is not followed exactly, a fire, explosion or production of carbon monoxide may result, causing property damage, personal injury or loss of life. The qualified service agency is responsible for proper installation of this kit. The installation is not proper and complete until operation of the converted appliance is checked as specified in the instructions supplied with the kit. Refer to appliance owner's manual or product data plate for proper inlet and manifold pressure adjustments and orifice sizing.

IMPORTANT: For high altitude installations above 4500 ft (1372 meters), consult local gas distributor or the authority having jurisdiction for proper derating methods.

KIT NUMBERS: **36-CKELP** for LP gas and **36-CKENG** for Natural Gas

KIT INCLUDES:

- Gas conversion label (303-0128)
- Burner orifice (part number 301-0068-48, #48 DMS [1.93 mm] for LPG) (part number 301-0068-30, #30 DMS [3.26 mm] for NG)
- Instruction Sheet
- SIT 885 Valve conversion kit c/w instructions & gas type label
- Intake Restrictor Plate (36-CKENG only)

**WARNING: SHUT OFF GAS SUPPLY AND ELECTRICAL POWER TO FIREPLACE
SHUT OFF GAS SUPPLY BEFORE DISCONNECTING ELECTRICAL POWER**

12.1 Prepare the Fireplace

Remove the surround, barrier screen, glass frame assembly, logs or glass media, embers and brick panels or firebox liner (if applicable)*.

Remove the burner*.

Remove or Install the intake restrictor*

*See relevant sections in this manual.

Remove the burner orifice using a 1/2" wrench. Replace with the orifice supplied with the conversion kit. Use a small amount of pipe sealant on the threads of the orifice mount. Do not use too much as it can block the orifice.



Figure 12.1.01:

12.2 Pilot Conversion

Using a 7/16" wrench and loosen the pilot hood 1/4 turn. Slide the tab at the bottom of the orifice hood all the way so the red side (propane) with the hole in it is showing. Tighten the pilot hood back up so that it is lined up with the two probes on both sides of the pilot assembly.

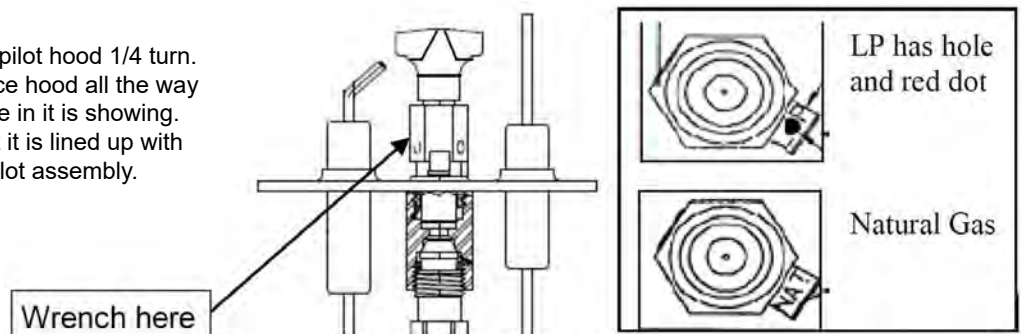

Figure 12.2.01:

Installation

12.3 Convert the Gas Valve

WARNING: Installation of this conversion kit must only be undertaken by a qualified and certified gas appliance installer.

Verify that the following items are present in the package:

- Pressure regulator assembly (E)
- Two (2) screws (F)
- Identification label (G)
- Installation instructions (this document)

1. Shut off the gas supply to the valve and shut down the electric supply.
2. See **Figure 12.3.01**. Using a Torx T20, or slotted screwdriver, remove and discard the two (2) pressure regulator mounting screws (A), pressure regulator tower (B), and the **spring and diaphragm assembly (C)**, (if applicable).
3. Ensure the rubber gasket (D), which is prefitted as part of assembly (E), is properly positioned, see **Figure 12.3.02**, otherwise fit the gasket as shown **Figure 12.3.02**.
4. Install the new STEPPER MOTOR pressure regulator assembly, as shown in **Figure 12.3.03** and **Figure 12.3.04**. Use the supplied screws (F), M4 x 0.7 threaded, length of thread $L = (16 \text{ mm} + 0 - 0.5 \text{ mm})$, steel material, resistance class 8.8 (see **Figure 12.3.05**).
5. Manually thread the two conversion kit mounting screws into the valve body. Use a standard screwdriver or T20 Torx bit and tighten to the screws with a fixing torque of $25 \text{ lb-in} \pm 5\%$.
IN THE EVENT THAT THE THREADS OF THE VALVE ARE STRIPPED OR DAMAGED, REPLACE THE VALVE.
6. Install the enclosed identification label (G) to the valve body where it can be easily seen.
7. Make STEPPER MOTOR and valve electrical connections, apply gas to system and relight appliance according to manufacturers instructions.
8. With the main burner "ON", test the new pressure regulator assembly for leaks using a soap solution.
9. Relight the main burner and verify proper burner ignition and operation.

WARNING: Installation should be carried out in a clean environment.

WARNING: This modulating conversion kit must ONLY be applied as part of a conversion kit supplied by the APPLIANCE MANUFACTURER.

WARNING: Correct operation of the system cannot be guaranteed if the conversion kit or valve has been dropped or has sustained a strong impact.

INSTALLER NOTICE: These instructions must be left with appliance.

12.4 Complete the Conversion

- **Remove the restrictor plate* (when converting to Propane)**
- **Install the restrictor plate* (when converting to NG)**
- Reinstall the burner, brick liners or firebox liner, logs or glass media, embers, and door*
- Turn on the gas and electrical supplies
- Turn on the fireplace so the burner is on
- Check for leaks at **all** connections

Test inlet and outlet pressure (See **Section 11.0**). Visually check pilot flame. Flame should envelope top of the flame sensor and extend forward onto the burner. To adjust pilot turn the pilot adjustment screw on the control valve clockwise to decrease or counter clockwise to increase pilot flame. Clock the rating as shown in **Section 11.1**. Adjust the primary air according to specifications in this manual or as found on the rating plate.

- Turn fireplace off
- Affix gas type label to the rating plate label (See **Section 6.1** for rating plate location)
- Complete the conversion label and affix to valve assembly plate
- Reinstall the barrier screen and surround*

*See relevant sections in this manual.

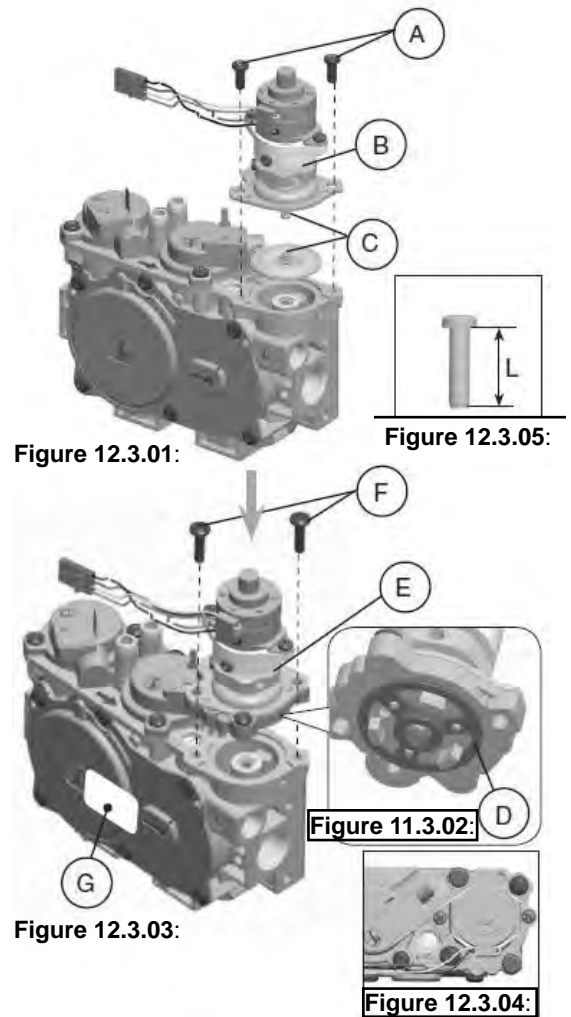

Installation

13.0 Venting Instructions

WARNING: Operation of this heater when not connected to a properly installed and maintained venting system can result in carbon monoxide (CO) poisoning and possible death. The appliance must not be connected to a chimney flue serving a separate solid fuel burning appliance.

CAUTION

Only approved 3" (76mm) double wall aluminum or stainless flex liners and approved vent terminals are to be used for this appliance.

This appliance is designed for dual 3" (76 mm) double wall aluminum flex liner. The liner must run the entire length of the chimney from the appliance to the termination.

The flue length must be a minimum of 10' (3.05 M) and a maximum of 40' (12.2 M) from the top of the gas fireplace insert.

Masonry chimneys may take various contours which the flexible liner will accommodate, however, keep the flexible liner as straight as possible, avoiding unnecessary bending but at all times keep a minimum of 3" (76 mm) inside bend radius.

The Air Intake Flex Liner must form a tight connection to the inlet air collars of the termination cap and the appliance.

The Exhaust Flex Liner must form a tight connection to the exhaust collars of the termination cap and the appliance.

The Air intake and Exhaust connections are marked on the gas appliance. See Figure 13.1.01.

DO NOT REVERSE THESE CONNECTIONS

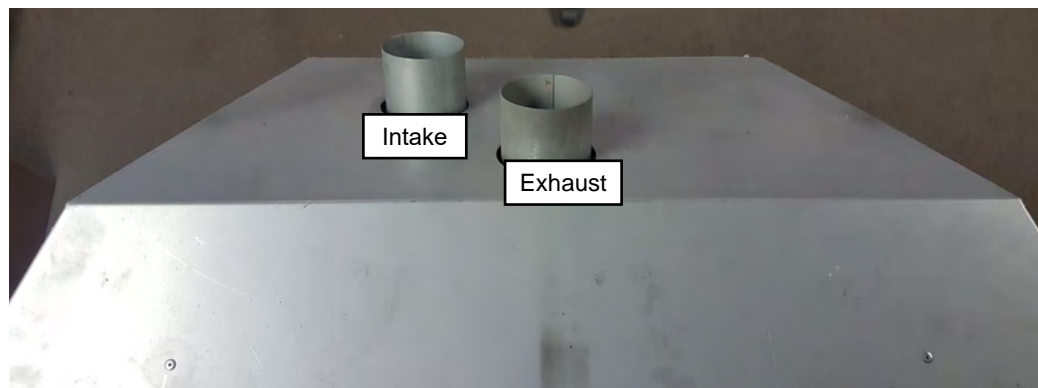

Figure 13.0.01: Intake & Exhaust as viewed from top of fireplace.

CAUTION

To ensure that the venting is not accidentally obstructed or punctured, the damper of the host fireplace must be permanently disabled by either complete removal of the damper, or by being fully blocked open, for the installation of a gas fireplace insert.

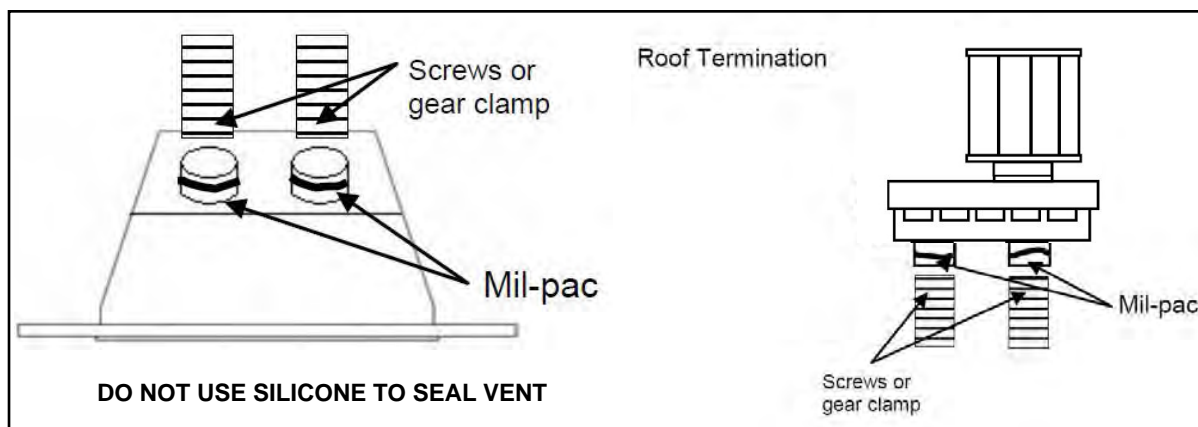

Figure 13.0.02:

Installation

13.1 Exhaust Restrictor

This appliance includes two exhaust restrictors in the manual bag. These restrictors may be required if the vent length exceeds 20' (6.1 M).

Vent length	
10' to 20' (3.05 M to 6.1 M)	No restrictor required
20' to 30' (6.1 M to 9.1 M)	Use one restrictor
30' to 40' (9.1 M to 12.2 M)	Use two restrictors

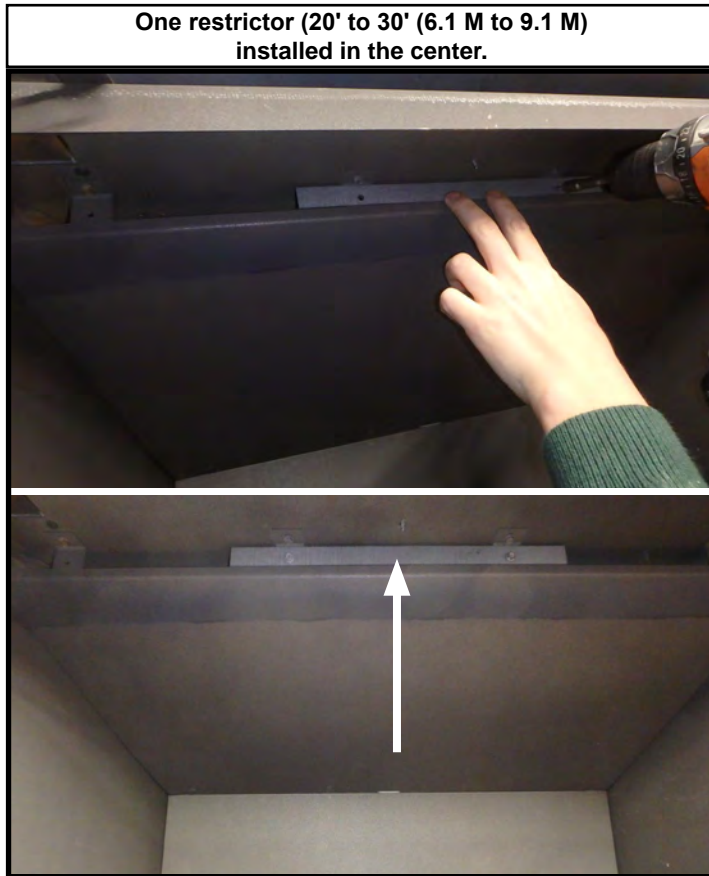

Figure 13.1.01:

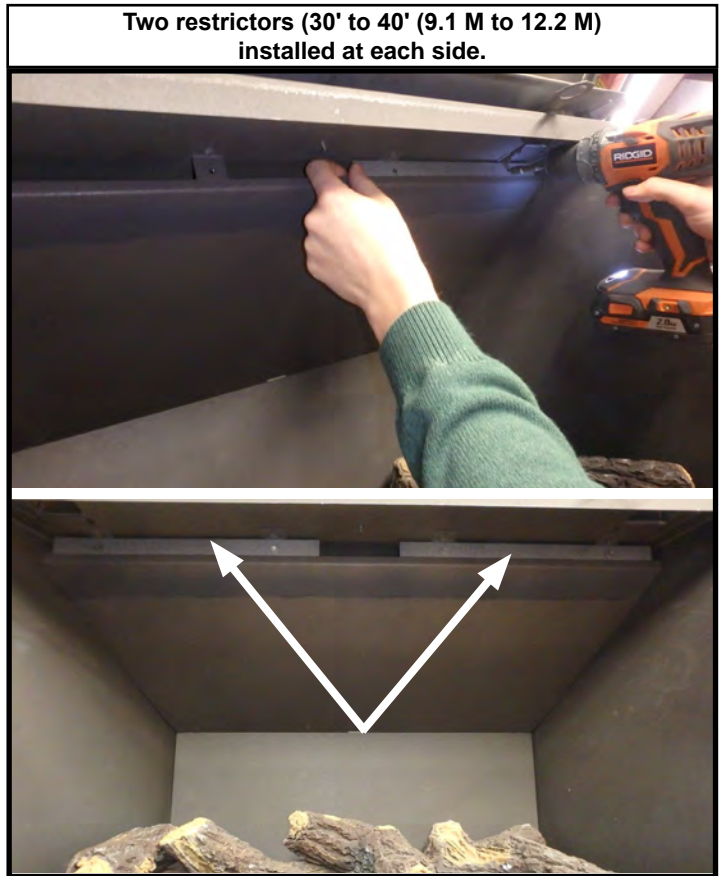

Figure 13.1.02:

13.2 Approved Terminations

Archgard Venting Components	
Vent Component	Part Number
Vertical Termination	999-INS-TK
3" x 30' Aluminum Flex Liner	999-INS-FL330
3" x 50' Aluminum Flex Liner	999-INS-FL350
Approved venting components from third party manufacturers may be found on the following page.	

Installation

Third Party Venting Components					
	BDM	Selkirk	Duravent	ICC	Amerivent
3" Flex (10ft)	95270310	AFE10-03	N/A	N/A	3ALKE10
3" Flex (25ft)	95270325	AF3-25L	3DFA-25	N/A	1730250
3" Flex (30ft)	95270330	N/A	N/A	N/A	N/A
3" Flex (35ft)	95270335	AF3-35L	3DFA-35	TC-3AL35	1730350
3" Flex (50ft)	95270350	AF3-50L	N/A	TC-3AL50	3ALKE50
3" Flex Coupling	95090390	AF3-FC	3DFA-FC	TM-CFAA3	Comes with
4x6 5/8 Coaxial High Wind Cap	DVR6-VCH	4DT-VC	46DVA-VCH	TM-4SVT	N/A
4x6 5/8 Coaxial Low-Profile Cap	DVR6-LPC	4DT-VT	N/A	N/A	4DVC
3x3 Colinear to 4x6 5/8 Coaxial Adapter	DVF33-A6	4DT-CBT, 4DT-AAC	46DVA-GK or 46DVA-CLTA	TM-CTA	4DCAT33
High Wind Shield Round	DVR68-VWG	N/A	46DVA-VWG	TM-SVTS	N/A
High Wind Shield Rectangular	N/A	N/A	N/A	TM-CTS	N/A
Co-linear High Wind Vert Term Kit (with 35 ft. Flex) for Masonry Chimney	94203370HWS	1604645	46DVA-CL33	TM-ALK33	DVIK33 (Not High Wind)
Co-linear Rectangular Vent Term Kit (with 35 ft. Flex) for Masonry Chimney	N/A	N/A	N/A	TM-ALT33	N/A
Co-linear Direct Vent Factory Built Reline Kit High Wind Vert Term (with 35ft Flex)	N/A	N/A	46DVA-CL33KFB	TC-AL35, TM-IVT, TM-IVTP	N/A
3x3 Co-linear Round Vert Term	940033HWS	1604643	N/A	TM-IVT	DVCC33
3x3 Co-linear High Wind Vert Term Round Base	9400332RD	N/A	N/A	TM-IVT, TM-IVTP	N/A
3x3 Co-linear High Wind Vert Term Square Base	940033HWS	N/A	N/A	TM-IVT, TF-MFR, TF-MFC, TF-MF	N/A
Co-linear Masonry Flashing Rectangular Vert Term	N/A	N/A	N/A	TF-CTF, TF-CTFC	N/A
3x3 Co-linear Square Vert Term	940033, 9400330808SS	N/A	N/A	N/A	N/A
3x3 Co-linear Rectangular Vert Term	940034EC26SS	N/A	N/A	TM-CT3	N/A
Co-linear Masonry Flashing Rectangular Vert Term	N/A	N/A	N/A	TF-CTF, TF-CTFC	N/A
Prefab Chimney Flashing	N/A	N/A	N/A	TM-IVTP	N/A
3" Appliance Co-linear Flex Connector	N/A	4DT-CFC	46DVA-ADF	N/A	N/A
3x3 Co-linear Square Double Cap	940033DBL	N/A	N/A	N/A	N/A

ATTENTION

NO OTHER VENTING SYSTEM OR COMPONENTS MAY BE USED.

Part numbers shown are correct at the time of printing and should be confirmed with the manufacturer prior to purchase.

Follow manufacturer instructions for installation of termination.

Installation

13.3 Min/Max Vent Run

Instructions for installing venting and terminations (see list for approved venting and terminations).

Install the termination cap being sure to provide sufficient space (around and on top) so you do not impede the flow of air, both into and out of the cap. This cap is only to be used for non combustible installations. Do not recess into the top of the chimney.

1. Mark each end of one flex liner with "Air Intake".
2. Mark each end of the second flex liner with "Exhaust".
3. Pull the liner through the chimney.
4. Install the flashing.
5. Seal and attach the flex liner marked "Air Intake" to the vent terminal pipe marked "Air Intake" as per terminal manufacturers instruction. **DO NOT USE SILICONE.**
6. Seal and attach the flex liner marked "Exhaust" to the vent terminal pipe marked "Exhaust" as per terminal manufacturers instruction. **DO NOT USE SILICONE.**
7. Seal and attach the end of the flex liner marked "Air Intake" to the collar marked "Air Intake" on the appliance with the collar clamp provided with the unit. **DO NOT USE SILICONE.**
8. Seal and attach the end of the flex liner marked "Exhaust" to the collar marked "Exhaust" on the appliance with the collar clamp provided with the unit. **DO NOT USE SILICONE.**
9. Caulk all joints using a high temperature sealant such as milpac. **DO NOT USE SILICONE. Use of silicone sealants voids the warranty of the pilot assembly.**

NOTE: The flex liners must form a complete connection from the appliance flue collars to the vertical termination cap.

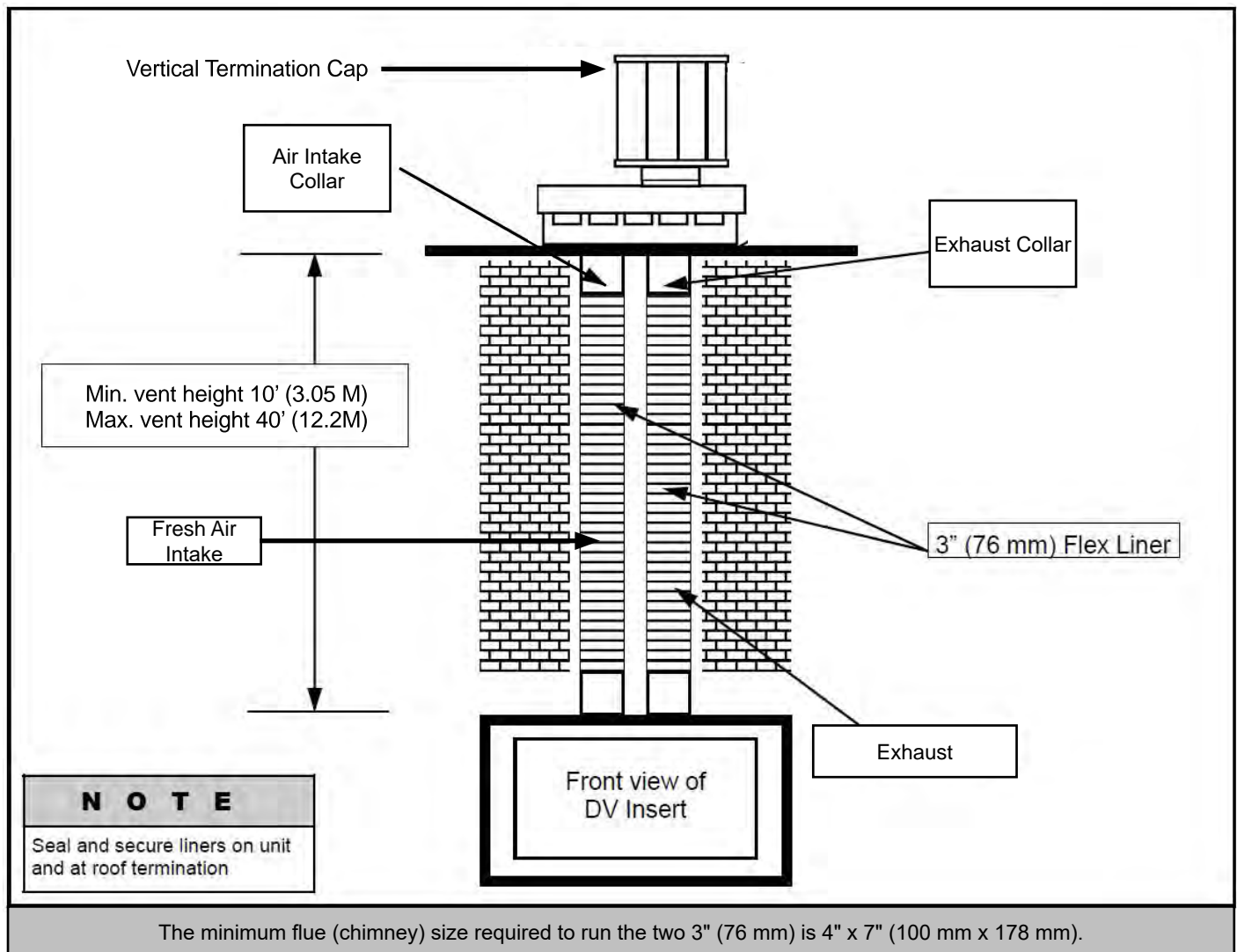

Figure 13.3.01:

General Information

13.4 Using a Co-linear to Coaxial Adapter

The gas fireplace can be converted from co-linear to coaxial when it is desired to remove a section of the masonry fireplace chimney to below the roof line.

WARNING

This appliance must be installed by a qualified gas appliance installer. The installation must conform with the local codes or, in the absence of local codes, with the current National Fuel Gas Code ANSI Z223.1/ NFPA 54 in the US, or Installation Code CAN/ CGA-B149.1 in Canada. Electrical connections and grounding must conform with local code, or current National Electrical code ANSI/NFPA No. 70-1987 in the US, and in Canada the current Canadian Electrical Code CSA C22.1.

- The sections of coaxial pipe cannot be longer than 6ft. or 50% of the total vent length, whichever is shorter
- A sealed flashing must be placed on top of the chimney where the co-linear to coaxial adapter is seated
- The total vent run must be a minimum of 10ft. from the top of the gas fireplace insert
- A 1" clearance must be maintained from the coaxial pipe to insulation and combustible material
- The termination must be 18" from the roof to the bottom of the termination

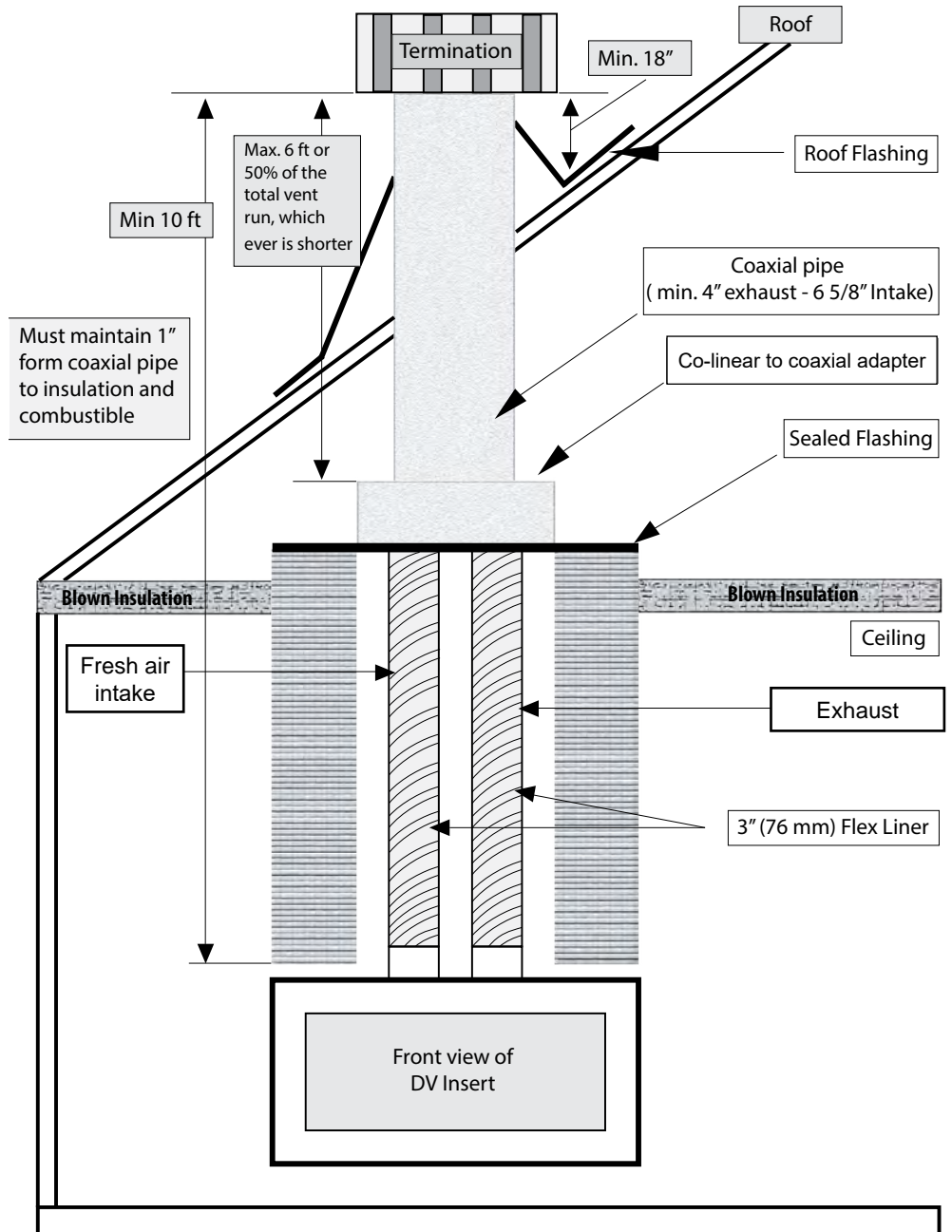

Figure 13.4.01:

14.0 Barrier Screen Installation

If barrier becomes damaged, the barrier shall be replaced with the manufacturer's barrier for this appliance (Part Number 36-BS).

Step 1: Align the tabs at the top of the screen with the opening on the edge at each side of the door. **Note:** fireplace shell top is not shown to illustrate installation.

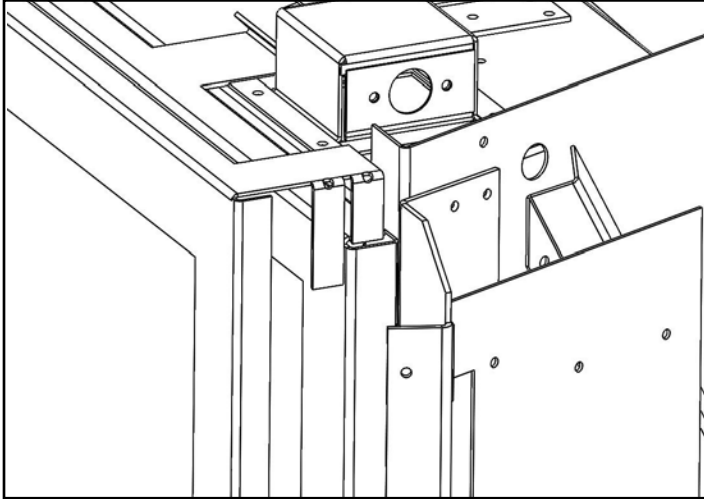

Figure 14.0.01:

Step 2: The hooks on the bottom of the barrier screen are designed to slide between the glass and the lower edge of the door frame.

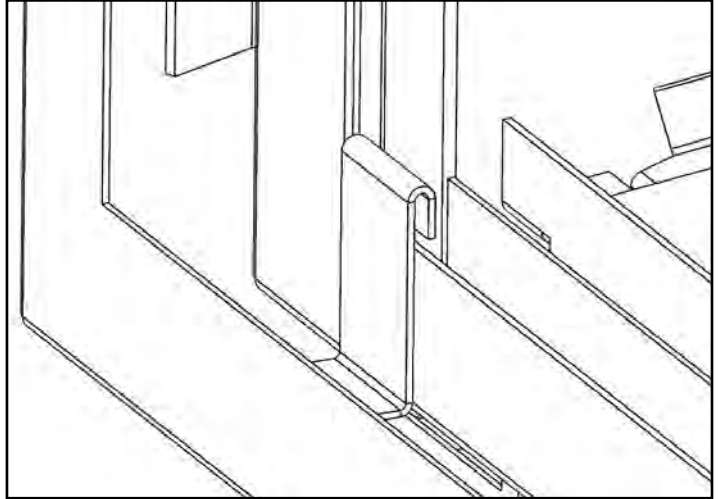

Figure 14.0.02:

Step 3: Slide the barrier screen down so that the outer tab on the screen engages with the top of the door.

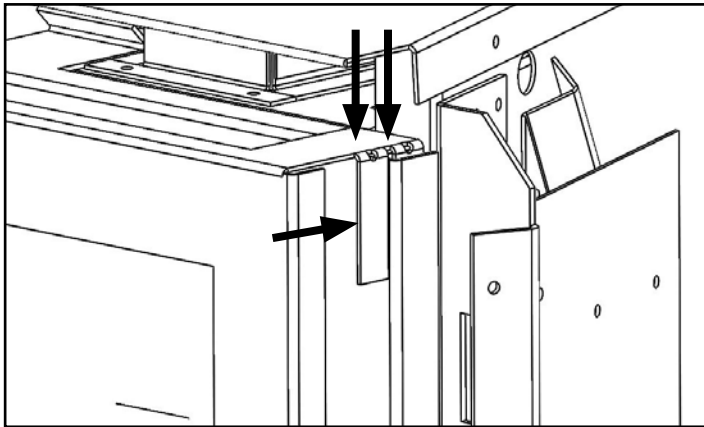

Figure 14.0.03:

Step 4: At the same time the lower hooks will slide between the glass and the lower edge of the door frame.

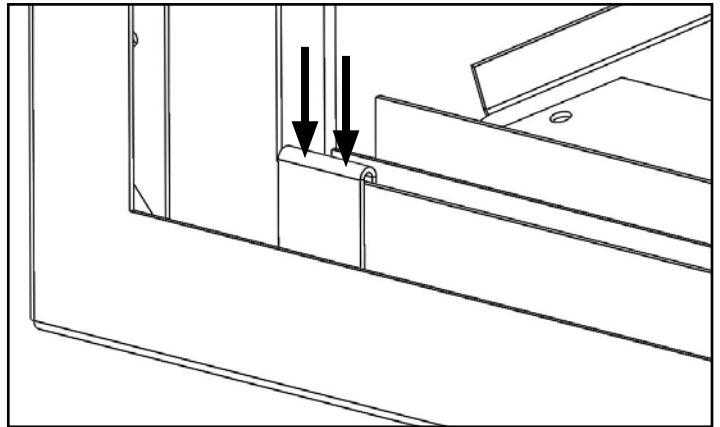

Figure 14.0.04:

*Removal is the reverse of installation.

15.0 Glass Door Installation

WARNING: Do not operate appliance with the glass front cracked or broken. Replacement of the glass should be done by a licensed or qualified service person. Do not attempt to remove the glass door when the appliance is hot. Be sure there are no fingerprints left on the glass panels during install or when cleaning as high temperatures can bake these prints on permanently. Inspect the door gasket to ensure no damage has occurred when installing the door.

Step 1: Hold the glass door at an angle so that the edge on the bottom of the door engages with the lower spring relief. Be sure that the door is centered and the entire length of the bottom edge is engaged.

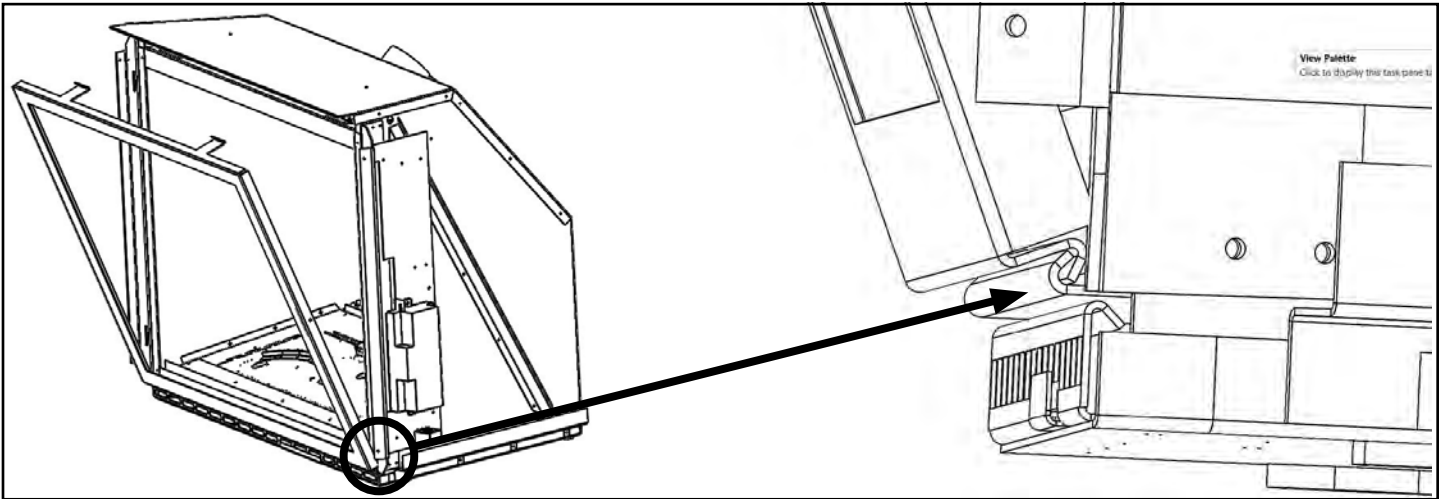

Figure 15.0.01:

Step 2: Rotate the top of the glass door upward.

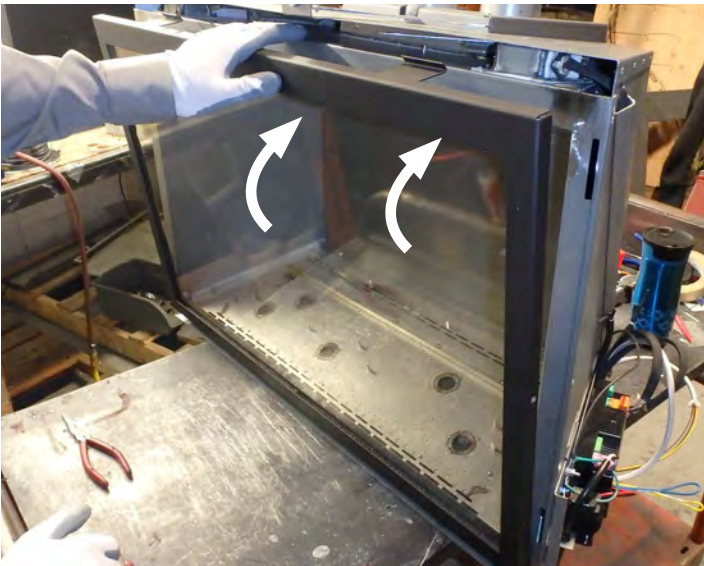

Figure 15.0.02:

NOTE: Make sure the upper door hooks do not impact with light boxes.

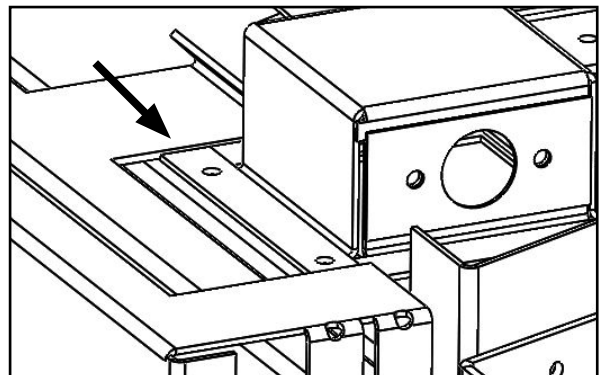

Figure 15.0.03:

Installation

Step 3: Rotate the door buckle handles outward.

Step 4: Pull the door buckle handles to engage with the hooks on the top of the door frame.

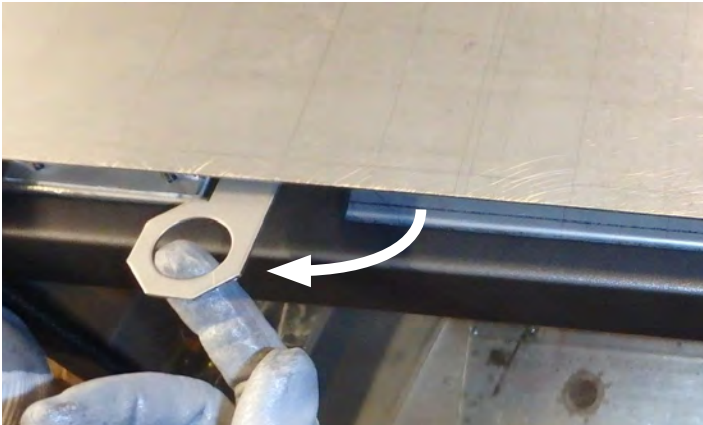

Figure 15.0.04:



Figure 15.0.05:

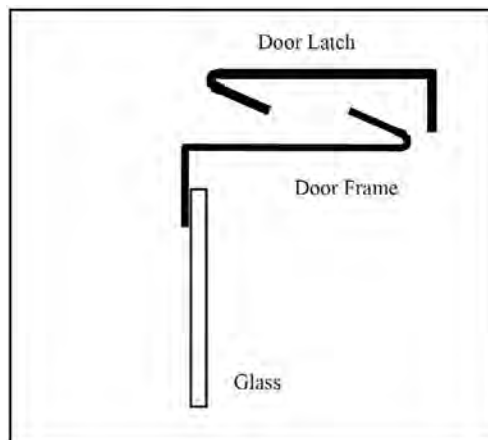

Figure 15.0.06:

*Removal is the reverse of installation.

15.1 If Your Glass Breaks

In the event your glass cracks or breaks, replace the original door assembly with Archgard replacement door assembly (part number RP-836-0000).

- Remove the barrier screen (See **Section 14.0**)
- Remove door as per the instructions above
- Replace with new door assembly and barrier screen

NOTE: the NEW door will emit some odor when the appliance is lit. The odor will dissipate after the gasket material within the door has cured. Be sure there are no fingerprints left on the glass panels as high temperatures can bake these prints on permanently.

Warning: Only doors certified with the appliance shall be used. Do not use substitute glazing materials.

16.0 Surround Installation

Before installing the surround, be sure the door is properly centered on the fireplace. Align the surround with the front of the fireplace. The surround contains four tabs (see **Figure 16.0.01**) which insert in slots in the fireplace (see **Figure 16.0.02**) to hold the surround in place. Align the tabs on both sides of the fireplace and hook the tabs in the slots to complete the install.

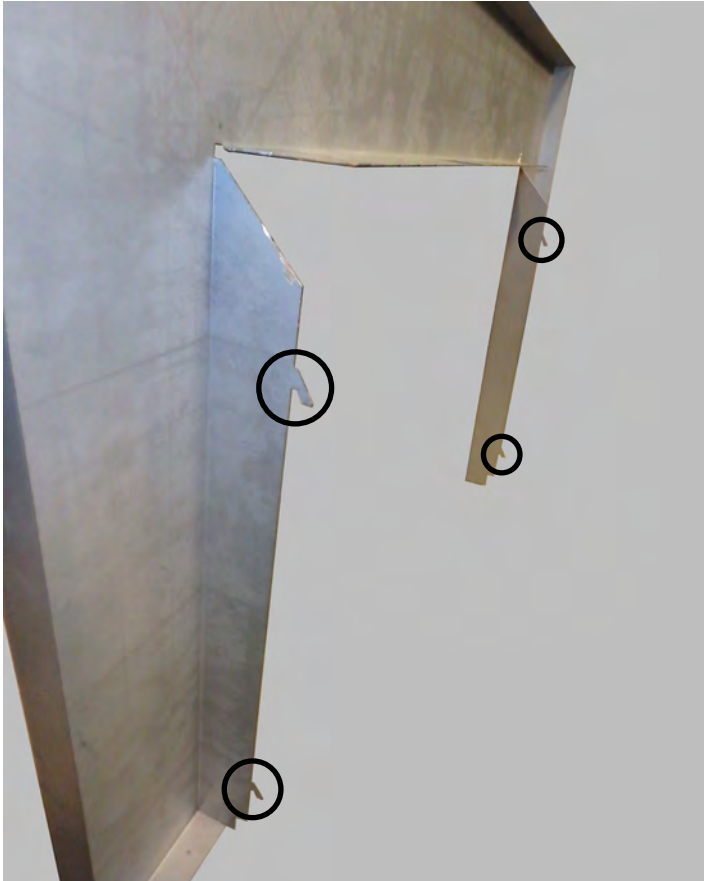

Figure 16.0.01:



Figure 16.0.02:



Figure 16.0.03:

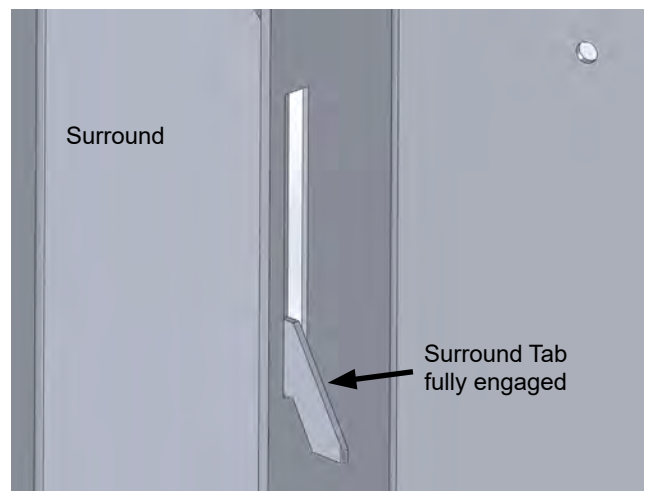

Figure 16.0.04: Surround installation drawing (view from behind the fireplace insert).

Installation

16.1 Dimensions of Surrounds

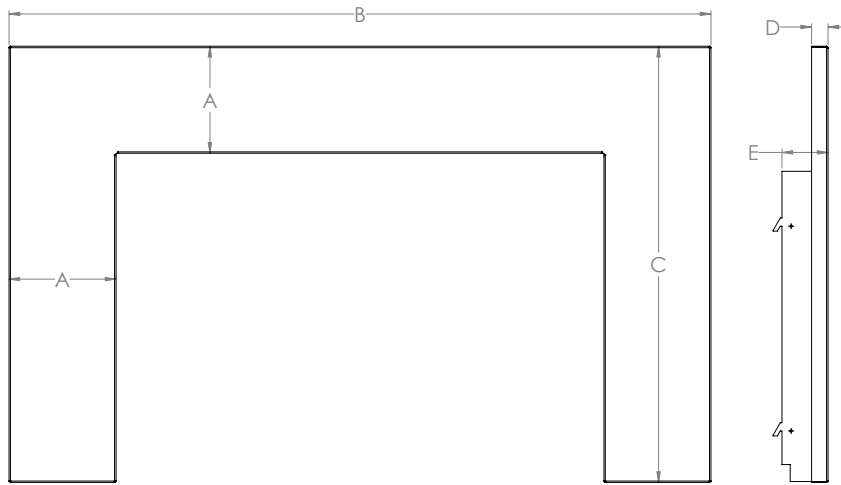

Figure 16.1.01:

Three Sided Surrounds				
	36-SKSBS Small Shallow	36-SKSBD Small Deep	36-SKLBS Large Shallow	36-SKLBD Large Deep
A	6.56" [16.66cm]		9" [22.86 cm]	
B	47.25" [119.99 cm]		52.125" [132.4 cm]	
C	30.31" [76.99 cm]		32.75" [83.19 cm]	
D	1" [2.54 cm]	2.5" [6.35 cm]	1" [2.54 cm]	2.5" [6.35 cm]
E	2.42" [6.15 cm]			

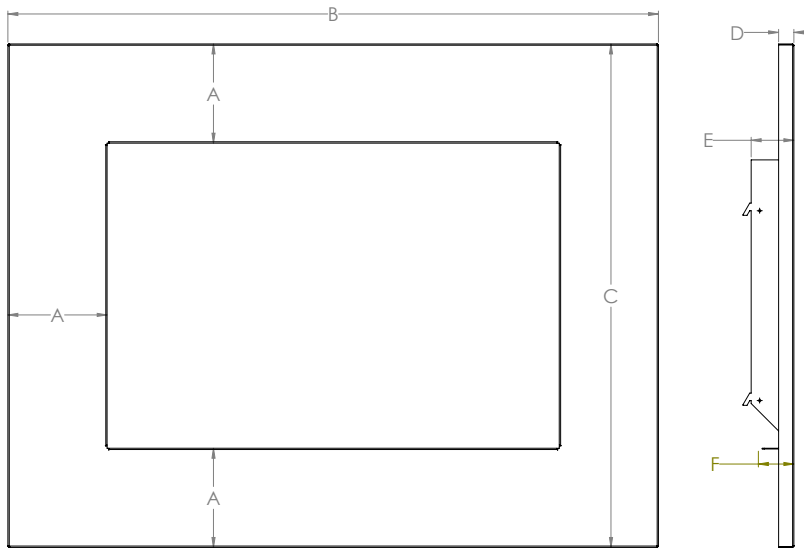

Figure 16.1.02:

Four Sided Surrounds				
	36-SK4SBS Small Shallow	36-SK4SBD Small Deep	36-SK4LBS Large Shallow	36-SK4LBD Large Deep
A	6.56" [16.66cm]		9" [22.86 cm]	
B	47.25" [119.99 cm]		52.125" [132.4 cm]	
C	36.96" [93.88 cm]		41.84" [106.27 cm]	
D	1" [2.54 cm]	2.5" [6.35 cm]	1" [2.54 cm]	2.5" [6.35 cm]
E	2.42" [6.15 cm]			

16.2 Trimmable Surround Dimensions

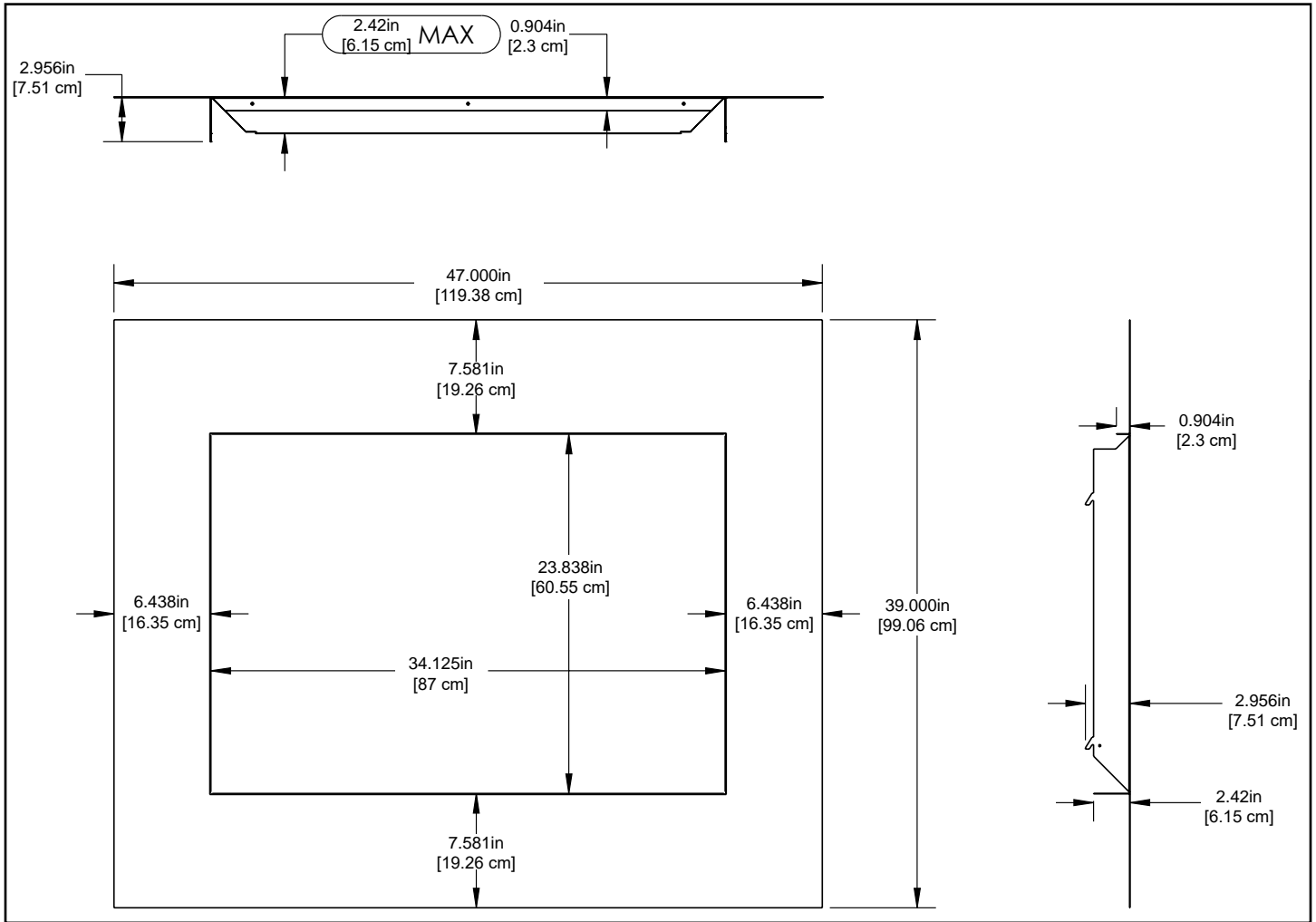
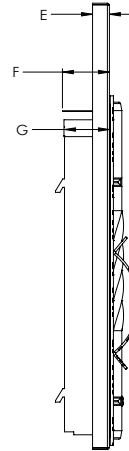
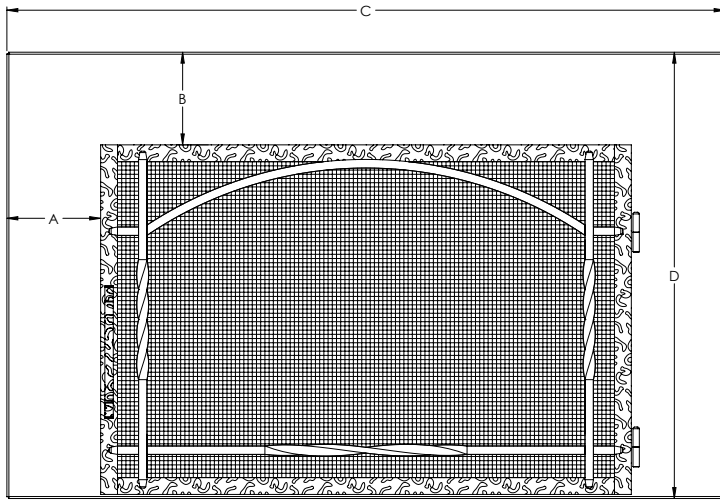

Figure 16.2.01:

16.3 Dimensions of Fronts



	Mission Hills Fronts	
	36-MHIFSSDBS	36-MHIFSSDBD
A	5.56" [14.12 cm]	
B	5.56" [14.12 cm]	
C	47.25" [120.02 cm]	
D	30.31" [76.99 cm]	
E	1" [2.54 cm]	2.5" [6.35 cm]
F	0.90" [2.29 cm]	
G	2.42" [6.15 cm]	

Figure 16.3.01: Mission Hills Front

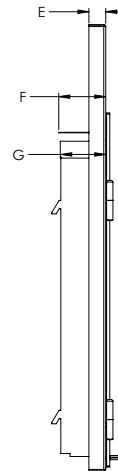
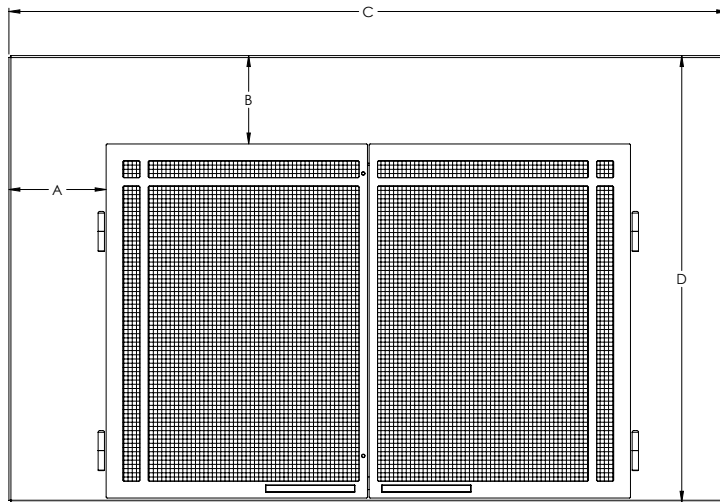

	Harrison Mills Fronts	
	36-SDSHMBS	36-SDSHMBD
A	5.5" [13.97 cm]	
B	4.91" [12.47 cm]	
C	47.25" [120.02 cm]	
D	30.31" [76.99 cm]	
E	1" [2.54 cm]	2.5" [6.35 cm]
F	0.90" [2.29 cm]	
G	2.42" [6.15 cm]	

Figure 16.3.02: Harrison Mills Front

16.4 Dimensions of Decorative Trims

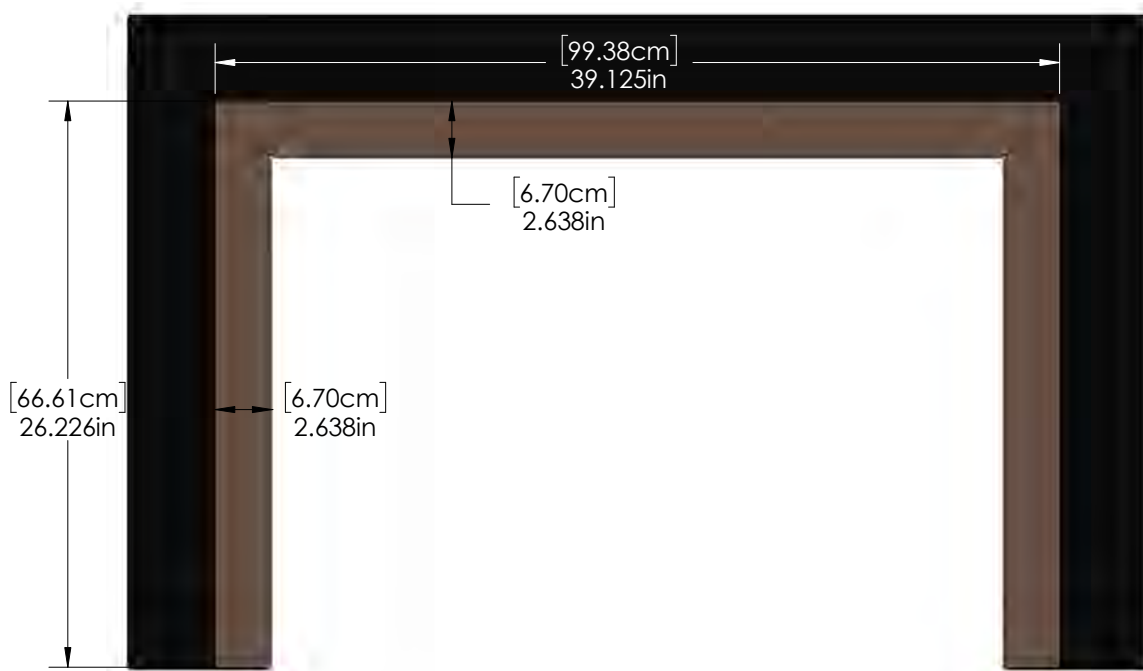

Figure 16.4.01:

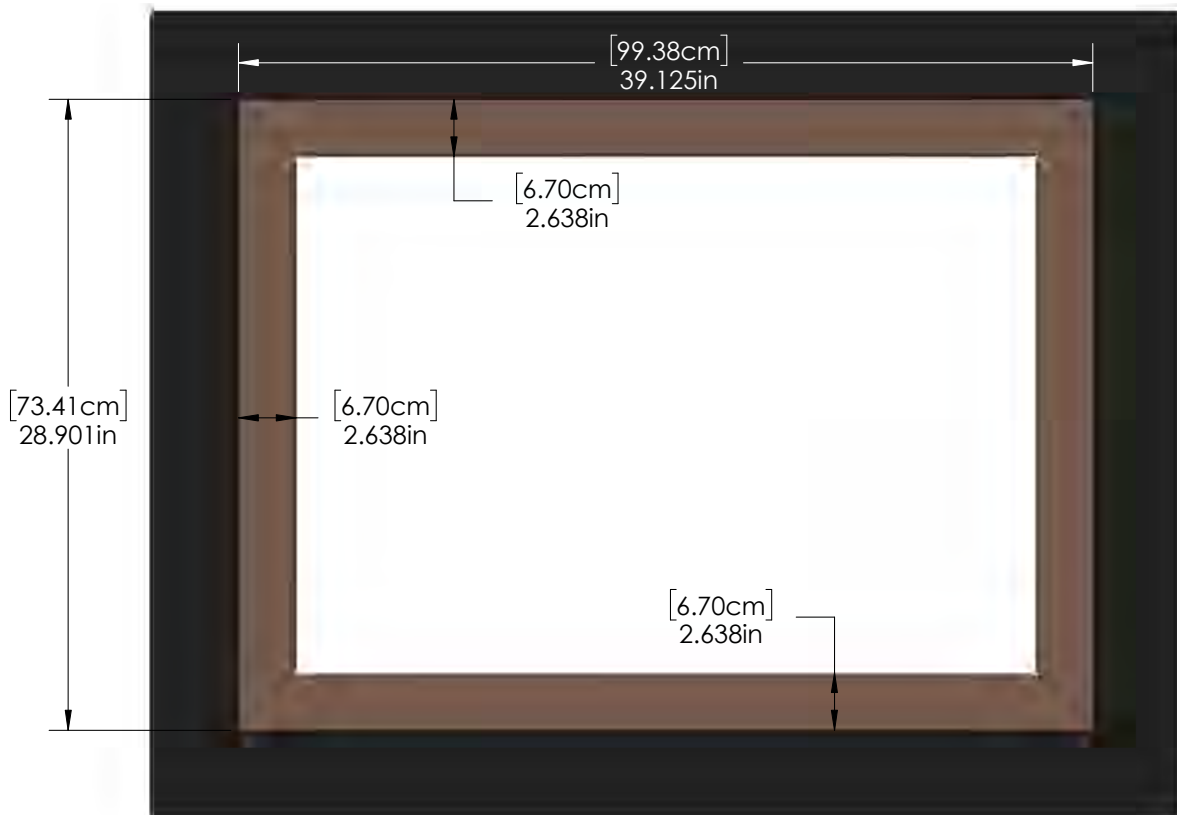

Figure 16.4.02:

16.5 Dimensions of Decorative Plinths

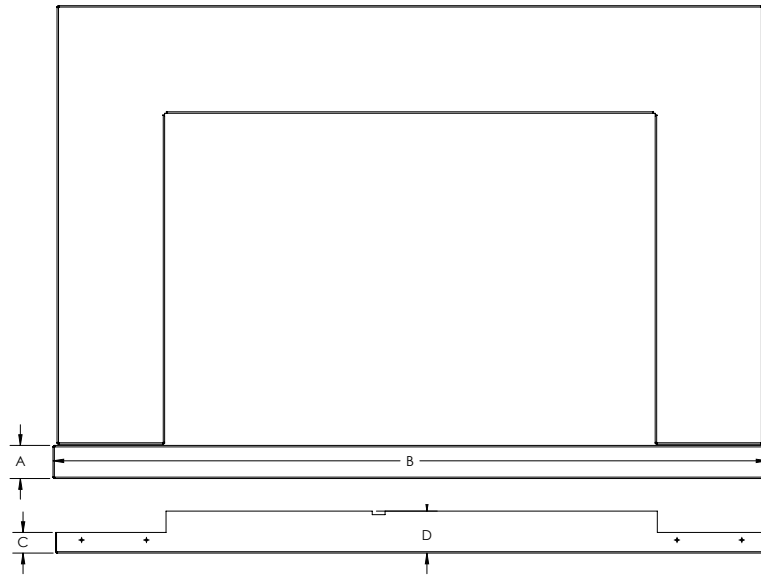

Figure 16.5.01:

Small Plinths

		For use with 36-SKSBS or 36-SKSBD			
		A	B	C	D
Shallow	36-DPSS2	2" 5.08 cm	47.75" 121.29 cm	1.25" 3.18 cm	2.67" 6.78 cm
	36-DPSS4	4" 10.16 cm			
	36-DPSS6	6" 15.24 cm			
Deep	36-DPSD2	2" 5.08 cm	47.75" 121.29 cm	2.67" 6.78 cm	2.67" 6.78 cm
	36-DPSD4	4" 10.16 cm			
	36-DPSD6	6" 15.24 cm			

Large Plinths

		For use with 36-SKLBS or 36-SKLBD			
		A	B	C	D
Shallow	36-DPLS2	2" 5.08 cm	52.63" 133.68 cm	1.25" 3.18 cm	2.67" 6.78 cm
	36-DPLS4	4" 10.16 cm			
	36-DPLS6	6" 15.24 cm			
Deep	36-DPLD2	2" 5.08 cm	52.63" 133.68 cm	2.67" 6.78 cm	2.67" 6.78 cm
	36-DPLD4	4" 10.16 cm			
	36-DPLD6	6" 15.24 cm			

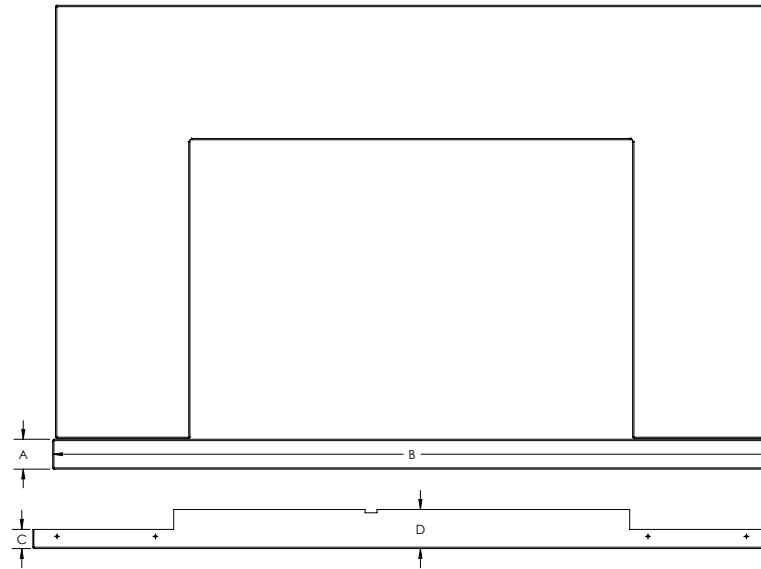

Figure 16.5.02:

16.6 Bottom Filler Plate

After installing the surround, align the Bottom Filler Plate included with your fireplace with the underside of the surround. Slide the plate under the lower edges on the surround as shown in **Figure 16.1.03**.

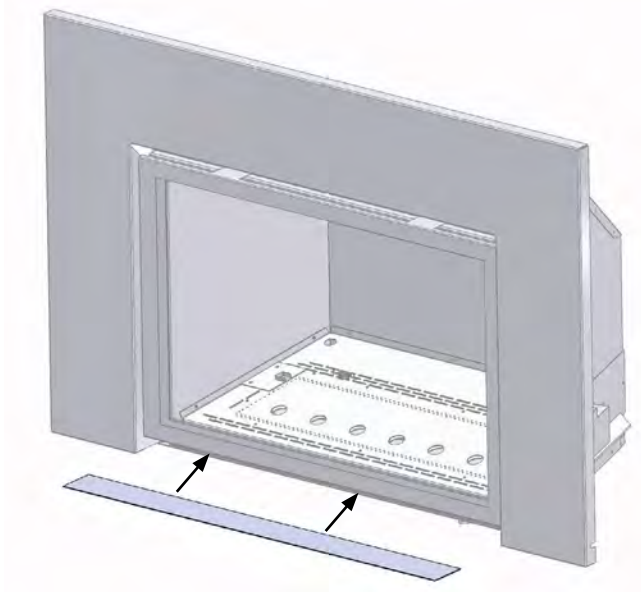

Figure 16.6.01:

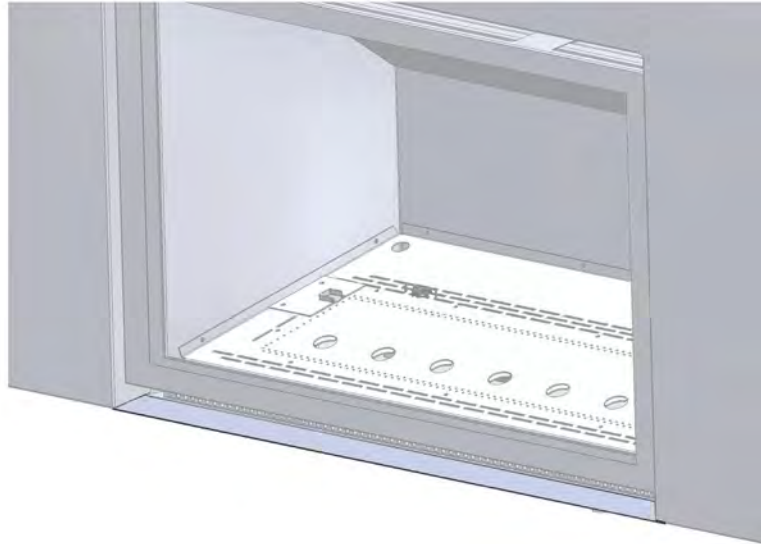

Figure 16.6.02:

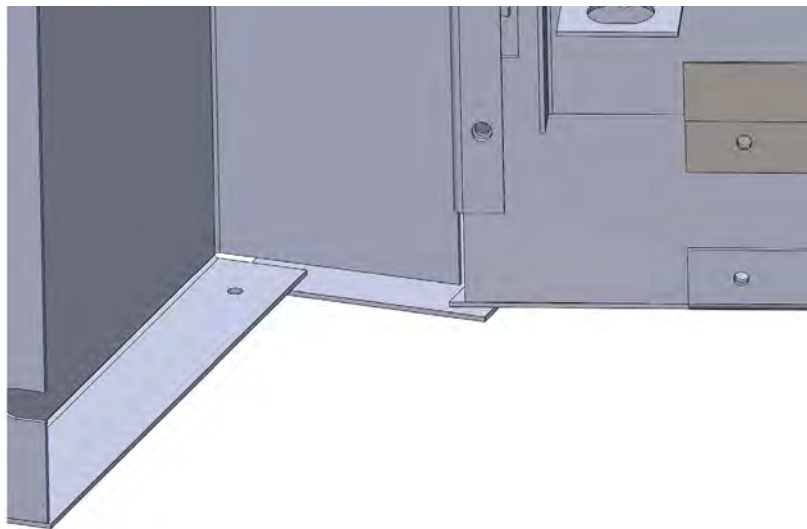

Figure 16.6.03:

17.0 Firebox Liner Installation

17.1 Brick Panel Installation

The following steps highlight the procedure for installing Quebec City Red or Quebec City Grey brick panel firebox liners. Handle the panels with care as they are delicate. Inspect the panels to ensure that no damage has occurred inside the package. Please report any damage immediately to your Authorized Archgard Dealer.

Before you begin:

- **Make sure the fireplace is off and cool prior to installation**
- **Ensure the gas supply is turned OFF, disconnect the power supply**
- Remove barrier screen (see **Section 14.0**)
- Remove Glass Door (see **Section 15.0**)

Removal is the reverse of Installation.

Step 1: Remove and retain the (2) Tek screws from the upper front corners.



Figure 17.1.01:

Step 2: Place the rear brick panel in the back of the firebox.



Figure 17.1.02:

Step 3: Place the left or right side panel.



Figure 17.1.03:

Step 4: Make sure both brick clips are accessible before continuing.

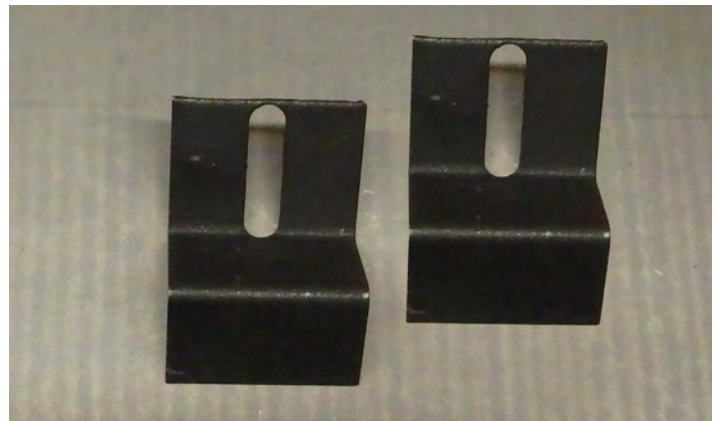

Figure 17.1.04:

Installation

Step 5: Secure first side panel using one of the panel retainer clips included with the fireplace and the screw removed in **Step 1**.



Figure 17.1.05:

Step 6: Align the upper panel on top of the rear panel and the first side panel. Continue to hold in place.



Figure 17.1.06:

Step 7: While holding the upper panel, align the remaining side panel.



Figure 17.1.07:

Step 8: Use the remaining brick panel retainer clip to secure the remaining side using the screw removed in **Step 1**.



Figure 17.1.08:



Figure 17.1.09: Completed Install

Installation

17.2 Reflective Glass Installation

Use the following steps to install the Eternal Flame Reflective Ceramic Glass liner. Handle the panels with care. Inspect the panels to ensure that no damage has occurred inside the package. Please report any damage immediately to your authorized Archgard Dealer. ensure no fingerprints are left on the glass panels as high temperatures can bake these prints on permanently. We recommend using clean, cotton gloves when handling the panels. The following photos show an unpainted fireplace to better illustrate installation.

Before you begin:

- **Make sure the fireplace is off and cool prior to installation**
- **Ensure the gas supply is turned OFF, disconnect the power supply**
- Remove barrier screen (see **Section 14.0**)
- Remove Glass Door (see **Section 15.0**)

Removal is the reverse of Installation.

Step 1: Remove and retain the (2) Tek screws at the rear of the firebox.



Figure 17.2.01:

Step 3: Locate the two lower panel retainer clips included with the panel set.

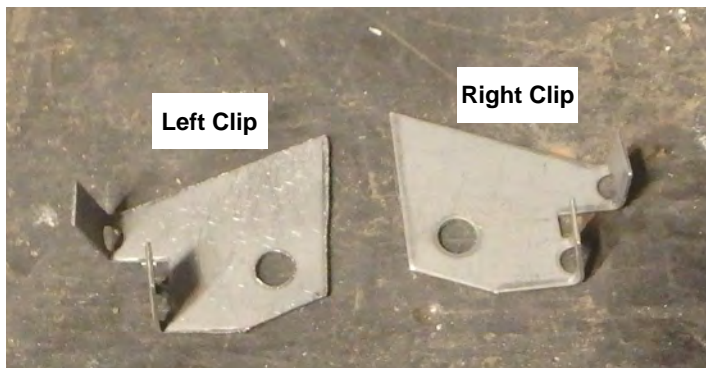

Figure 17.2.03:

Step 5: Install the left clip as shown using one of the Tek screws removed in **Step 1**.



Figure 17.2.05:

Step 2: Remove and retain the (2) Tek screws from the upper front corners.



Figure 17.2.02:

Step 4: Ensure the upper panel retainer clips are accessible for the following steps.

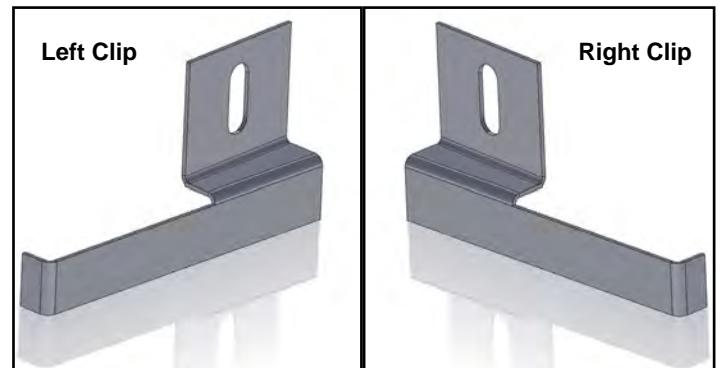

Figure 17.2.04:

Step 6: Repeat for the right clip.



Figure 17.2.06:

Installation

Step 7: Place the rear panel in the back of the firebox.



Figure 17.2.07:

Step 8: Continue to support the rear panel and place the left or right side panel (left panel shown) in the lower panel retainer clip.

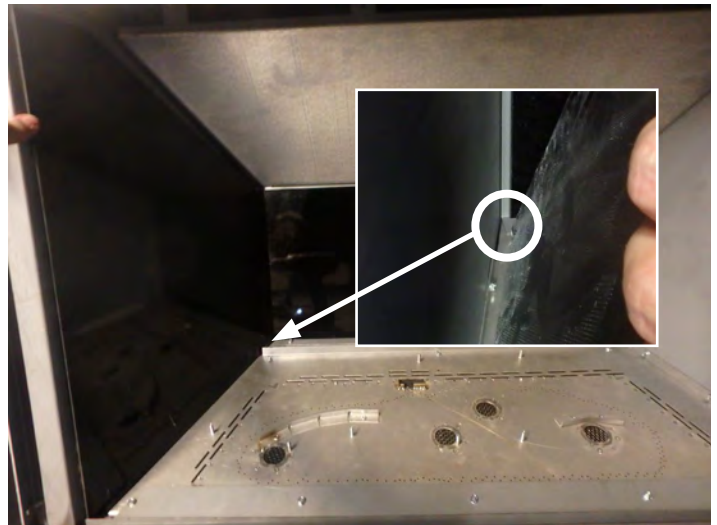

Figure 17.2.08:

Step 9: Install the left panel retainer clip to secure the left panel in place.

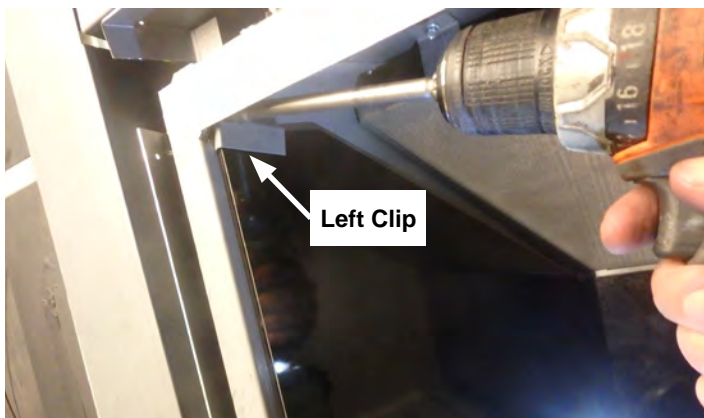

Figure 17.2.09:

Step 10: Repeat **Step 8** through **Step 9** for the right panel.

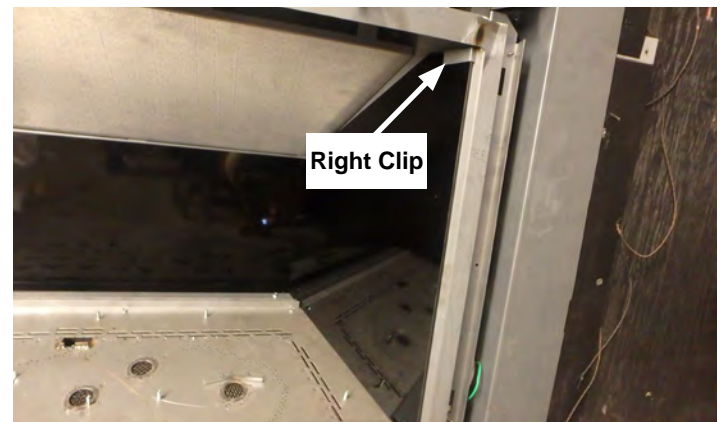

Figure 17.2.10:

Step 11: Insert the upper panel toward the front of the firebox at an angle, placing one edge over a side panel.



Figure 17.2.11:

Step 12: Rotate the upper panel so that both sides are above the upper edge of the left and right side panels, then slide toward the back of the firebox to rest on top of the side and rear panels.



Figure 17.2.12:

18.0 Media Installation

WARNING

Failure to position the parts in accordance with these diagrams or failure to use only parts specifically approved with this appliance may result in property damage or personal injury.

18.1 Log Set

The Archgard pan burner bed and fiber logs are designed to give a realistic fire package, and created to look the same as the day they were originally installed. Care must be given when handling the logs as they can be damaged or broken if not handled properly.

After opening the log set package, inspect the logs to ensure that no damage has occurred inside the package. Please report any damage immediately to your Authorized Archgard Dealer.

Gas and vent connection must be made before installing the embers and logs on the pan burner.

CAUTION: DO NOT block pilot opening with embers.

NOTE: Improper placement of logs and embers may cause soot accumulation on the internal parts and glass. This is not covered under warranty. Do not use broken or damaged logs.

Step 1: Align the air shield included with the fireplace.



Figure 18.1.01:

Step 2: Secure using (2) Tek screws included with the fireplace.



Figure 18.1.02:

Step 3: Place the first log as shown with the end butting against the air dam.

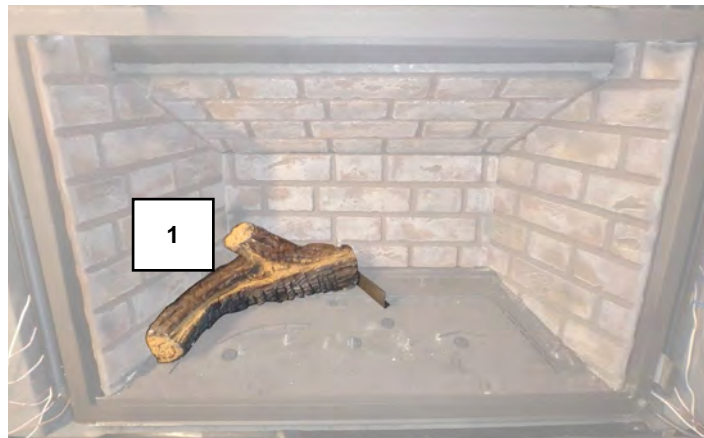

Figure 18.1.03:

Step 4: Place the second log in the right side of the firebox.

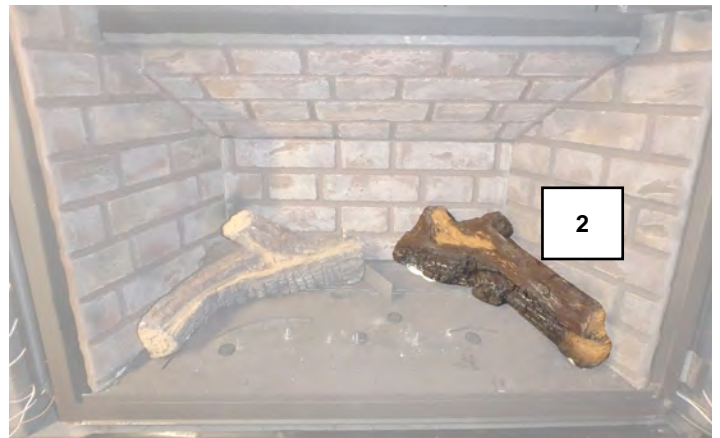

Figure 18.1.04:

Installation

Step 5: Place a few embers above the ember ledges. Do not block secondary air under the logs. Do not block burner openings.



Figure 18.1.05:

Step 6: Place the third log using the locator pins and the hole in the bottom of the log.

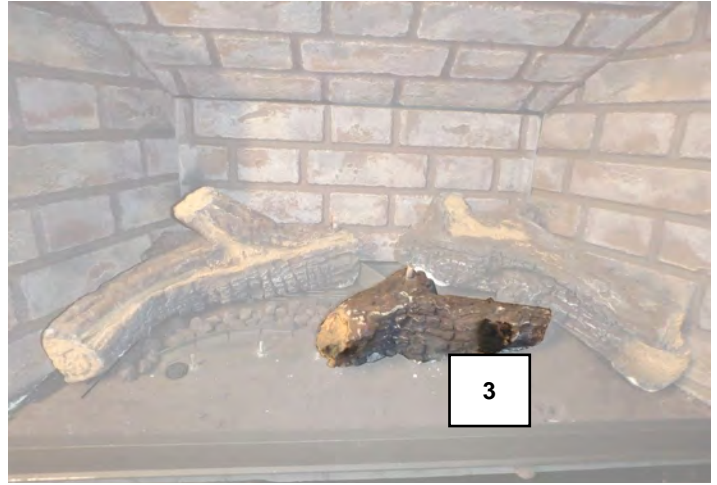

Figure 18.1.06:

Step 7: Continue to add embers between the logs in the back of the fireplace. Do not block secondary air under the logs. Do not block burner openings.



Figure 18.1.07:



Figure 18.1.08:

Step 8: Place the fourth log using the locator pins. This log is contoured to provide superior secondary air.

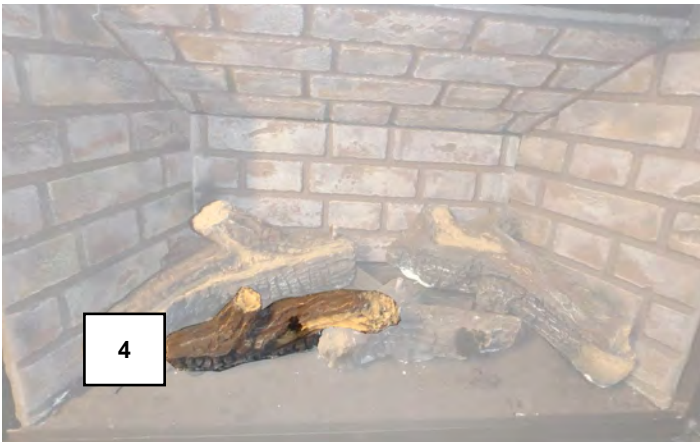

Figure 18.1.09:

Step 9: Place the fifth log using the locator pins on the first log and the third log.

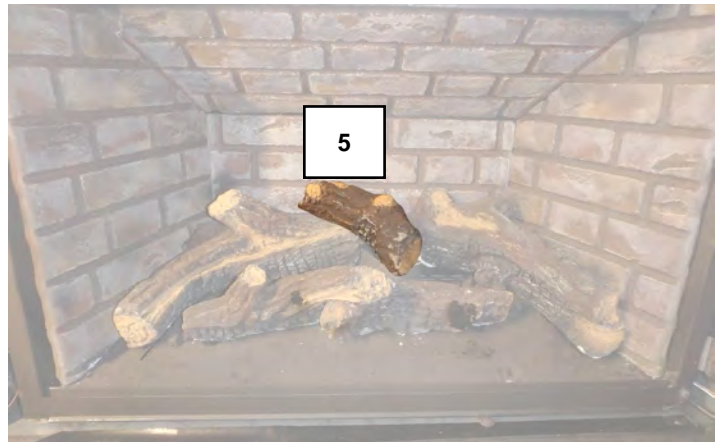

Figure 18.1.10:

Installation

Step 10: Place the sixth log on top of the first log.



Figure 18.1.11:

Black Ember Placement

IMPORTANT

Embers should be placed so they do not completely block burner ports. DO NOT block pilot opening.

Step 1: Place an even layer of embers along the front of the logs up to the secondary air dam. Be sure to leave some spacing between the embers along the air dam and along the edge of the logs to promote air flow.



Figure 18.1.12:

Step 2: Place an even layer of embers along the top of the Air dam. Be sure embers do not overlap those placed above the air dam as it may impede air flow.



Figure 18.1.13:

Platinum Ember Placement

IMPORTANT

Embers should be placed so they do not completely block burner ports. DO NOT block pilot opening.

Platinum embers provide a brighter glow than the black embers. When using a mixture of both the firebox will be filled with a naturalistic glow.

Step 1: Remove embers from the bag. Be sure to follow handling instructions on the bag.

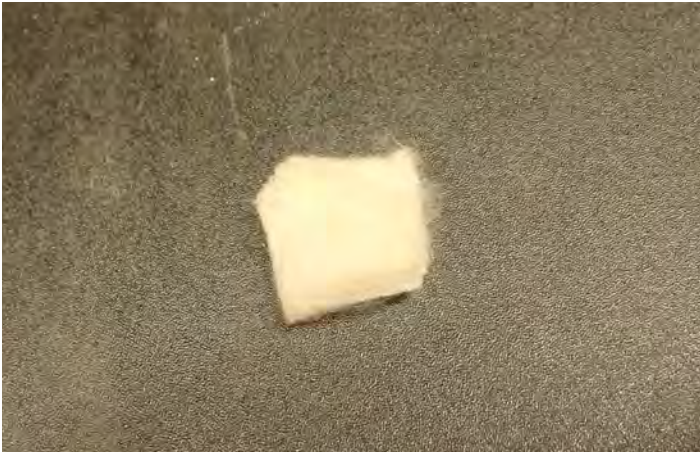

Figure 18.1.14:

Step 2: Separate embers by pulling apart. Embers may be flattened or separated into smaller pieces to achieve any desired aesthetic.



Figure 18.1.15:

Step 3: Place the embers randomly throughout the fire bed, taking care to avoid burner openings.



Figure 18.1.16:

Installation

Installation Overview

ATTENTION

When placing embers around the pilot shield take care to not block the pilot opening. Failure to keep the opening clear of embers will cause a delayed ignition.

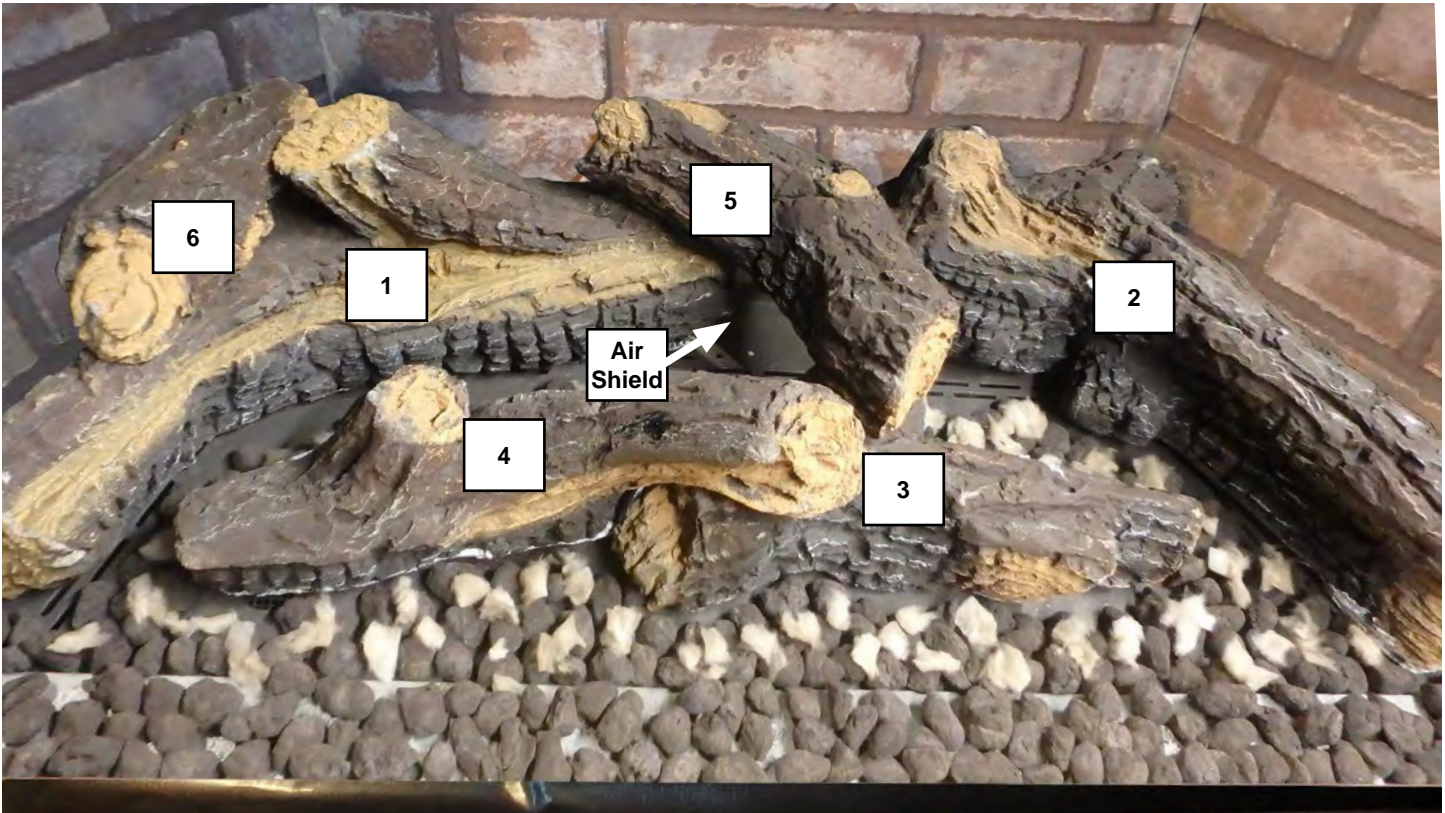

Figure 18.1.17:

Part #	Item Description	Qty	Part #	Item Description	Qty
310-6400-01	Log Set	1 Set	310-6400-5	Log 5 (Upper Middle)	1
310-6400-1	Log 1 (Left Rear)	1	310-6400-6	Log 6 (Upper Left)	1
310-6400-2	Log 2 (Right Rear)	1	733-5159-REVA	Air Shield	1
310-6400-3	Log 3 (Front Right)	1	310-0020	Black Embers (2 cup bag)	2
310-6400-4	Log 4 (Front Left)	1	310-0019	Platinum Embers (1 bag)	1

WARNING

Never use unapproved burner media such as rock wool or similar material. The use of unapproved burner media may cause damage or injury and will void product warranty.

19.0 Operation

19.1 Before Lighting

WARNING: If you do not follow these instructions exactly, a fire or explosion may result causing property damage, personal injury or loss of life. Do not operate the appliance with the glass front removed, cracked or broken. Replacement of broken glass should be done by a licensed or qualified service person.

Each Archgard Gas Fireplace is checked and tested at the factory prior to being packaged and shipped to our dealers and finally installed in your home. Archgard recommends that before leaving this unit with the customer, the installer must ensure that the appliance is firing correctly and that the electrical system is in working order. This will include:

1. Performing leak tests of supply line, gas control valve, supply line from gas control valve and pilot assembly.
2. Clocking the appliance to ensure the correct firing rate (see page 6 of this manual).
3. If required, adjusting the primary air to burner to ensure that the flame does not carbon or soot.
4. Checking for proper operation including correct drafting.
5. Turning the fireplace ON to ensure that the fan is working correctly. After the system has been checked and confirmed that the fan is in working order, refer to the instructions for FIRST FIRE located in this manual.

Use the installation checklist in **Section 5.0** to ensure all installation steps have been completed.

Note: Any alteration to this product that causes carbon or soot deposits that results in any damage or requires cleaning is not the responsibility of the manufacturer.

Do not store or use gasoline or other flammable vapors and liquids in the vicinity of this or any other appliance.

WHAT TO DO IF YOU SMELL GAS:

- Do not try to light any appliance.
- Do not touch any electrical switch; do not use any phone in your building.
- Immediately call your gas supplier from a neighbor's phone. Follow the gas supplier's instructions.
- If you cannot reach your gas supplier, call the fire department.

Installation and service must be performed by a qualified installer, service agency or the gas supplier.

1. **BEFORE LIGHTING**, smell all around the appliance area for gas. Be sure to smell next to the floor, because some gasses are heavier than air and will settle on the floor.
2. **IF YOU SMELL GAS**, follow the instructions as listed directly above or as shown on the front cover of this manual.
3. Do not use this appliance if any part has been under water. Immediately call a qualified service technician to inspect the appliance and to replace any part of the control system and any gas control which has been under water.
4. This appliance is equipped with an ignition device which automatically lights the pilot and main burner when operating the remote control.

19.2 First Fire

When operated for the first few times, the appliance will emit some odor and fumes. This is due to the heat from the appliance evaporating the oils and solvents used in fabricating the appliance. Close off the room to the rest of the house and open all windows. Keep the room well ventilated, as smoke alarm may sound. Run the appliance for at least 6 hours at maximum setting with blower set to "OFF" to allow paint to cure (after the installer has checked to ensure the fan is operational). Smoke and fumes caused by the curing process may cause discomfort to some individuals. Clean the glass door after this curing process has completed (see **Section 20.1**). Be sure there are no fingerprints left on the glass panels as high temperatures can bake these prints on permanently.

19.3 Lighting Instructions

The following information may be found on the fireplace rating plate. See **Section 6.1** for the rating plate location.

FOR YOUR SAFETY READ BEFORE LIGHTING
POUR VOTRE SÉCURITÉ VEUILLEZ LIRE AVANT L'ALLUMAGE

WARNING: If you do not follow these instructions exactly, a fire or explosion may result causing property damage, personal injury or loss of life.

AVERTISSEMENT: Quiconque ne respecte pas à la lettre les instructions dans la présente notice risque de déclencher un incendie ou une explosion entraînant des dommages, des blessures ou la mort.

A. This appliance is equipped with an ignition device which automatically lights the pilot. Do not try to light the pilot by hand. When lighting the pilot follow these instructions exactly.

B. BEFORE OPERATING smell all around the appliance area for gas. Be sure to smell next to the floor because some gas is heavier than air and will settle on the floor.

WHAT TO DO IF YOU SMELL GAS

- Do not try to light any appliance.
- Do not touch any electrical switch; do not use any phone in your building.
- Immediately call your gas supplier from a neighbor's phone. Follow the gas supplier's instructions
- If you cannot reach your gas supplier, call the fire department.

C. Do not use this appliance if any part has been under water. Immediately call a qualified service technician to inspect the appliance and to replace any part of the control system and any gas control which has been under water.

A. Cet appareil est équipé d'un dispositif d'allumage qui allume automatiquement la veilleuse. N'essayez pas d'allumer la veilleuse à la main. Respectez les instructions ci-dessous à la lettre.

B. AVANT D'ALLUMER la veilleuse, reniflez tout autour de l'appareil pour détecter une odeur de gaz. Reniflez près du plancher, car certains gaz sont plus lourds que l'air et peuvent s'accumuler au niveau du sol.

QUE FAIRE SI VOUS SENTEZ UNE ODEUR DE GAZ:

- Ne pas tenter d'allumer d'appareil
- Ne touchez à aucun interrupteur; ne pas vous servir des téléphones se trouvant dans le bâtiment
- Appelez immédiatement votre fournisseur de gaz depuis un voisin. Suivez les instructions du fournisseur.
- Si vous ne pouvez rejoindre le fournisseur, appelez le service des incendies.

C. N'utilisez pas cet appareil s'il a été plongé dans l'eau, même partiellement. Faites inspecter l'appareil par un technicien qualifié et remplacez toute partie du système de contrôle et toute commande qui ont été longés dans l'eau.

LIGHTING INSTRUCTIONS
INSTRUCTION D'ALLUMAGE

1. STOP! Read the safety information above on this label. This appliance is equipped with an ignition device which automatically lights the pilot. Do not try to light the pilot by hand.
2. Set the remote control switch to "OFF".
3. Open the lower louvers, or remove trim and barrier screen.
4. Turn off all electric power to the appliance.
5. Open the gas isolation valve.
6. Wait 5 minutes to clear out any gas. Then smell for gas, including near the floor. If you smell gas, STOP! and follow "B" in the safety information above (and to the left) on this label. If you do not smell gas, go to the next step.
7. Turn on all electric power to the appliance.
8. Set the remote control switch to "ON".
9. If the fireplace does not light, the system will cycle through two trials (one minute of audible clicking, thirty seconds of silence, and then another one minute of audible clicking). If the system locks out due to inadequate gas flow, refer to troubleshooting in instruction manual.
10. If the system will not function correctly, follow the instructions "To turn Off Gas To Appliance" below and call your service technician or gas supplier.
11. Replace louver or trim.

1. ARRÊTEZ! Lisez les instructions de sécurité sur la portion supérieure (à droite) de cette étiquette. Cet appareil est équipé d'un dispositif d'allumage qui allume automatiquement la veilleuse. N'essayez pas d'allumer la veilleuse à la main.
2. Réglez le commutateur à distance sur "OFF".
3. Ouvrez persiennes inférieurs ou garnir.
4. Coupez l'alimentation électrique de l'appareil.
5. Vanne d'isolement de gaz ouverte.
6. Attendre cinq (5) minutes pour laisser échapper tout le gaz. Reniflez tout autour de l'appareil, y compris près du plancher, pour détecter un odeur de gaz. Si vous sentez une odeur de gaz, ARRÊTEZ! Passez à l'étape B des instructions de sécurité sur la portion supérieure (à gauche) de cette étiquette. S'il n'y a pas d'odeur de gaz, passez à l'étape suivante.
7. Réglez le commutateur à distance sur "ON".
8. Allumez l'alimentation électrique de l'appareil.
9. Si le foyer ne se allume pas, le cycle de la volonté du système grâce à deux essais (une minute de clic audible, trente secondes de silence, et puis un autre une minute de clic audible). Si le système se bloque en raison de l'écoulement de gaz insuffisante, voir le dépannage dans le manuel d'instruction.
10. Si le système ne fonctionne pas correctement, suivez les instructions «Pour couper le gaz de l'appareil» ci-dessous et appelez votre technicien d'entretien ou fournisseur de gaz.
11. Persienne fermée ou garnir.

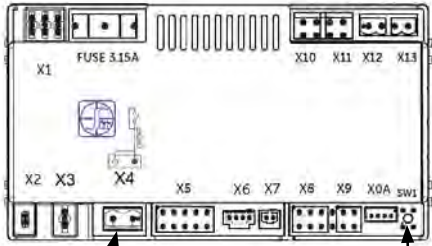

Proflame 885 Board

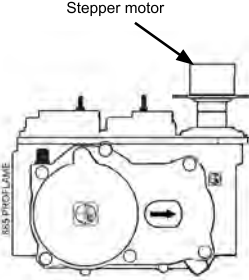

Proflame 885 Valve

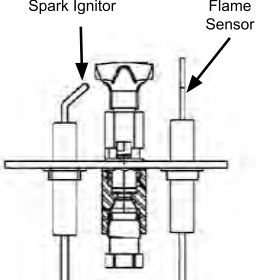

Pilot

TO TURN OFF GAS TO APPLIANCE
POUR COUPER LE GAZ À L'APPAREIL

1. Set the remote control switch to "OFF".
2. Turn off all electric power to the appliance if service is to be performed.
3. Open louver or access panel.
4. Turn incoming gas isolation valve to "OFF" position.
5. Close louver or trim.

1. Réglez le commutateur à distance sur "OFF".
2. Coupez l'alimentation électrique de l'appareil s'il faut procéder à l'entretien.
3. Ouvrez persiennes inférieurs ou porte d'accès.
4. vanne d'isolement de gaz à proximité
5. Persienne fermée ou garnir.

Figure 19.3.1:

19.4 Dynamic Start Advantage

This fireplace comes standard with the Dynamic Start Advantage. This new electronic ignition system is the latest in fireplace technology. It helps to create a better draft, better flame appearance, less condensation on the glass, and years of carefree operation.

How the system works:

When starting a solid fuel wood burning fireplace you build a fire. You start with a little bit of tinder and kindling to create small fire, and then work your way up to larger logs once a draft has been established. Dynamic Start uses the same principle. When you press the "ON" button on the remote control the main burner will light and remain with a low flame for two minutes. This will first establish a draft in the vent and slowly warm up the fireplace. When two minutes have passed, the main burner will automatically ramp up to the high flame (or whichever setting you have established on the remote control).

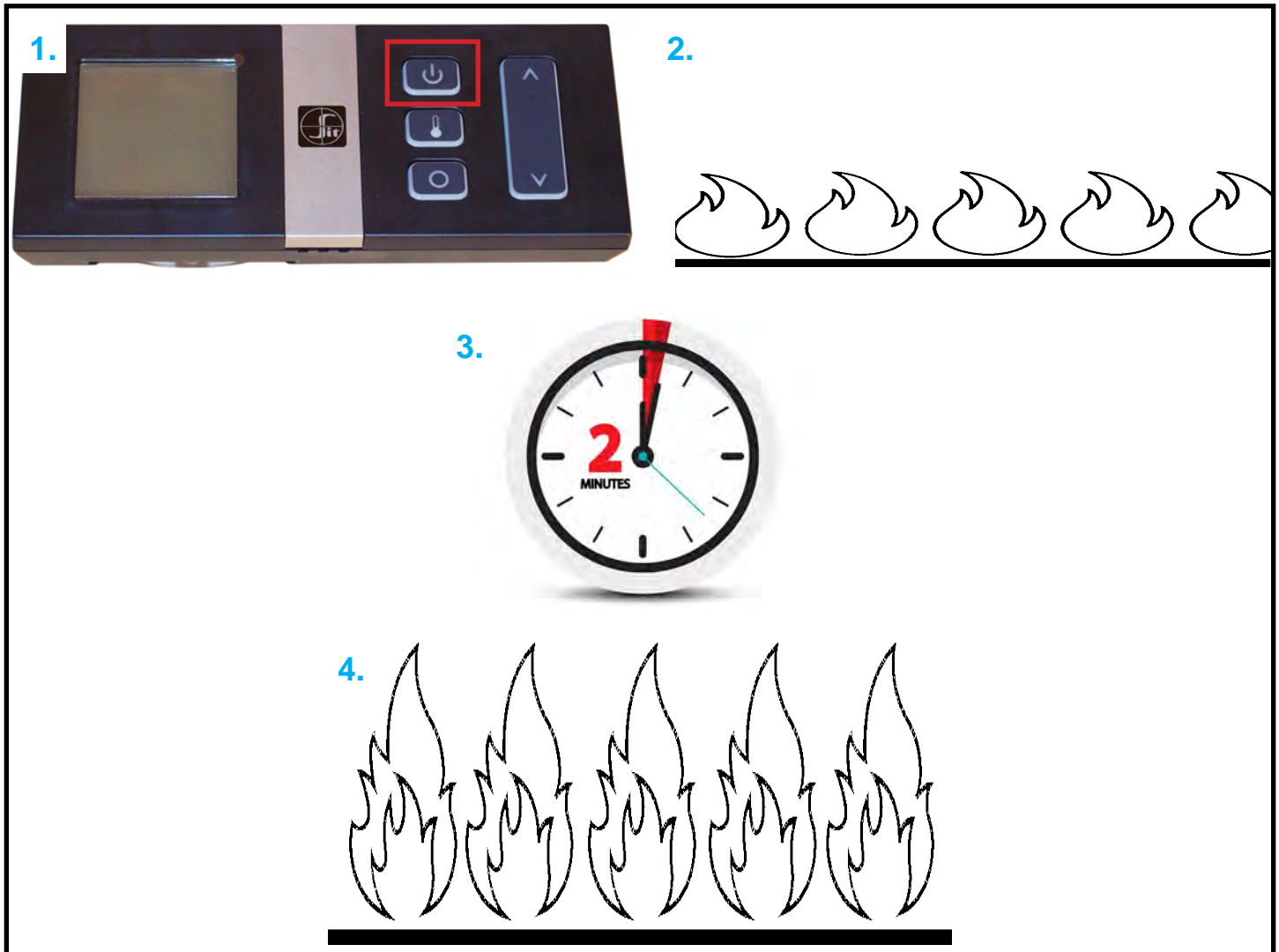

Figure 19.4.01

19.5 Remote Control Operation

IMPORTANT

The Proflame II Remote is an integrated part of the Proflame II System, which consists of a Proflame II Remote, to be used in conjunction with Integrated Fireplace Control (Proflame II Control Module).



Figure 19.5.01

The Proflame II Remote provides for controlling the following hearth appliance functions:

1. Main Burner ON/OFF
2. Main Burner flame modulation (6 levels)
3. Choice of Continuous Pilot on Demand or intermittent pilot (CPI/IPI)
4. Thermostat and SMART thermostat function
5. Comfort fan speed modulation (6 levels)
6. Variable lights (6 levels)

The Proflame Remote uses a streamline design with a simple button layout and informative LCD display. A Mode Key is provided to index between the features and a Thermostat Key is used for on/off or to index through the thermostat function. Additionally a Key Lock function is provided.

ATTENTION

- TURN OFF THE MAIN GAS SUPPLY DURING INSTALLATION OR MAINTENANCE OF THE RECEIVER DEVICE
- TURN OFF MAIN GAS SUPPLY TO THE APPLIANCE PRIOR TO REMOVING OR REINSERTING THE BATTERIES
- IN CASE OF REMOTE CONTROL MALFUNCTION TURN OFF THE FIREPLACE BY REMOVING POWER SUPPLY (INCLUDING BACKUP BATTERIES)
- FOR INSTALLATION/MAINTENANCE SWITCH OFF THE FIREPLACE BY REMOVING POWER SUPPLY (INCLUDING BACKUP BATTERIES)

Technical Data - Remote Control

Supply Voltage	4.5 V (three (3) 1.5V AAA batteries)
Ambient temperature ratings	0 - 50°C (32 - 122°F)
Radio Frequency	315 MHz

Operation

Handheld Remote Display

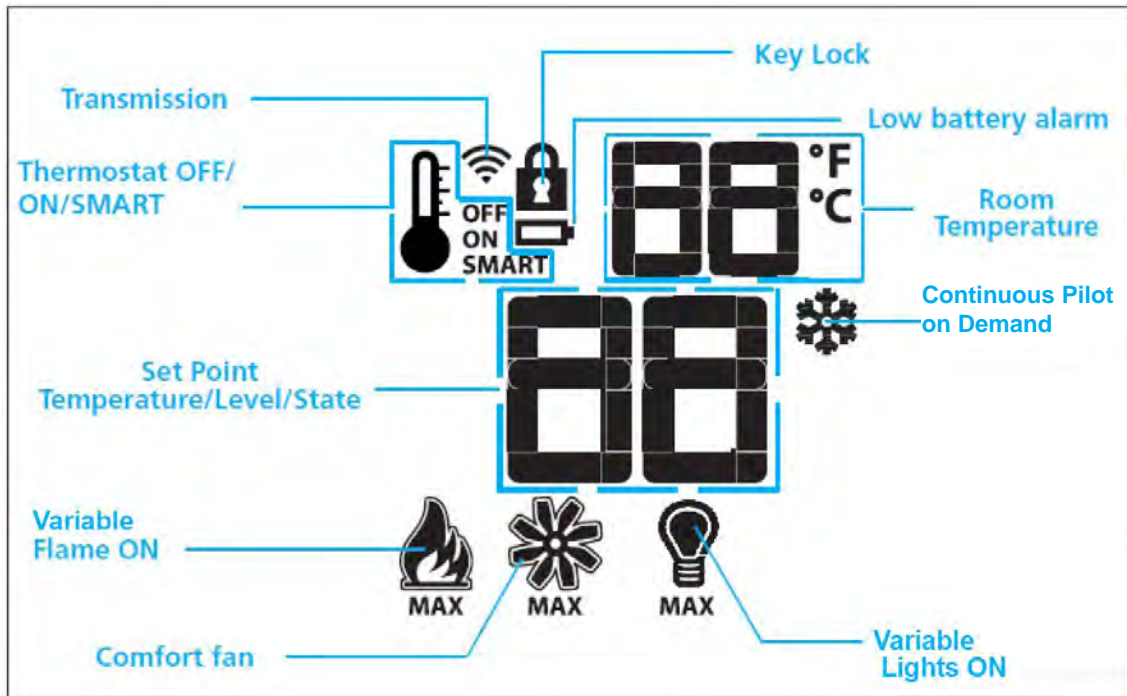

Figure 19.5.02

WARNING

THE REMOTE AND RECEIVER ARE RADIO FREQUENCY DEVICES. PLACING THE REMOTE IN OR NEAR METAL ENCLOSURES MAY REDUCE THE SIGNAL RANGE.

Hand held Remote (optional)



Figure 19.5.03

Operation

Initializing the System for Handheld / Wall Mount Remote Operation

1. Connect IFC Control Module to AC power supply. A single “beep” will indicate the presence of power. **NOTE: This will initiate Pilot Start-up in Manual Mode. The pilot will spark repeatedly and ignite if gas has been supplied to the unit. Sync the control board to the remote to turn main burner and pilot off using the steps below.**
2. The ON/OFF Override Jumper on the control board must be connected.
3. Press and hold the red SW1 button until the IFC module beeps three (3) times and/or the amber LED illuminates indicating the module is ready to synchronize with the remote.
4. Within ten (10) seconds push the ON/OFF key on the remote. The IFC module will “beep” four (4) times to indicate that it has successfully synced with the remote. Turn the fireplace OFF using the ON/OFF button on the remote to complete initialization. The remote will now control the fireplace.
5. Install the provided four (4) AA batteries into battery back up holder.

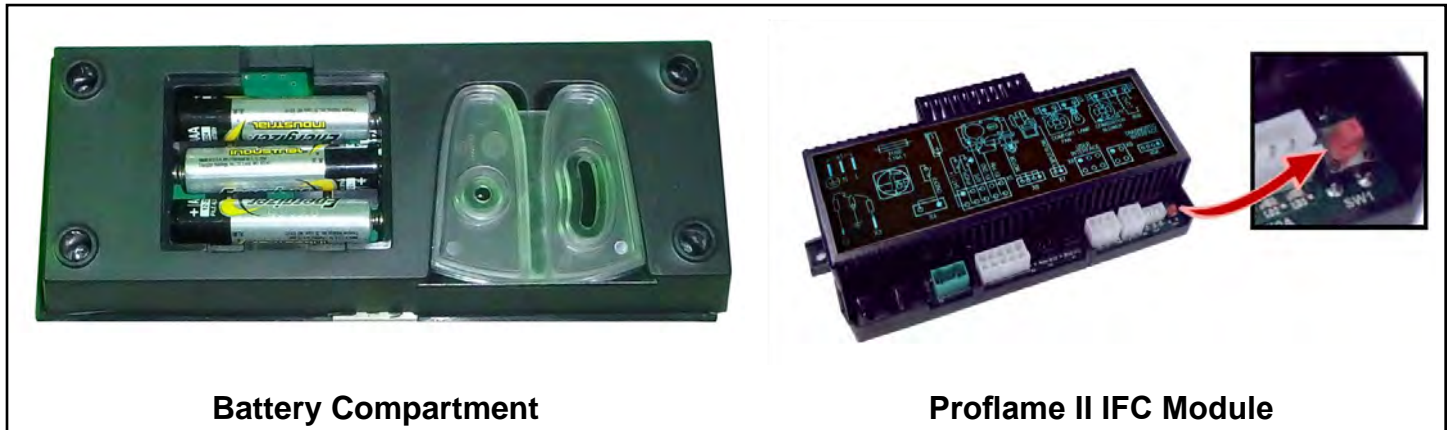

Figure 19.5.04:

Turn "ON" the Appliance

With the system OFF, press the ON/OFF Key on the Remote. The Remote display will show other active icons on the screen. At the same time the Receiver will activate the appliance. A single “beep” from the receiver will confirm reception of the command.

Turn "OFF" the Appliance

With the system ON, press the ON/OFF Key on the Remote. The Remote display will show the current room temperature. At the same time the Receiver will turn the appliance off. A single “beep” from the receiver will confirm reception of the command.

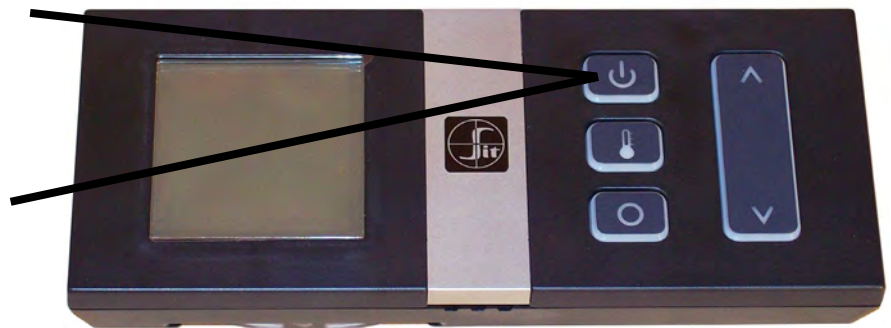

Figure 19.5.05:

Operation

Temperature Indication Display

With the system in the "OFF" position, press the Thermostat Key and the Mode Key at the same time to switch between Fahrenheit (F) or Celsius (C). Verify on the LCD screen the correct designation is visible.

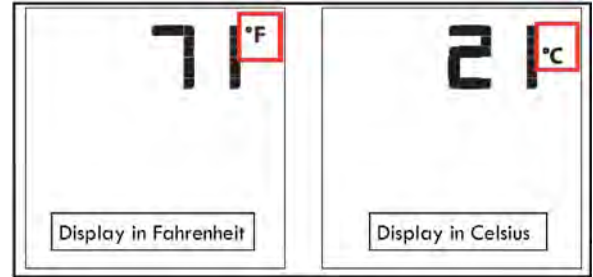

Figure 19.5.06:

Variable Flame Control

This function is disabled when in SMART Thermostat Mode and does not operate in the first two minutes of operation during the Dynamic Start Advantage.

The Proflame IFC has six (6) flame levels. With the system "ON" and the flame at maximum in the appliance, pressing the Down Arrow Key once will reduce the flame height by one step. Repeat to lower the flame till "OFF". With flame OFF in this configuration, fan and lights will still be operational.

The UP Arrow Key will increase the flame height each time it is pressed.

If the UP Arrow Key is pressed while the system is on but the flame is off, the flame will activate in the high setting.

A single "beep" will confirm reception of the command.

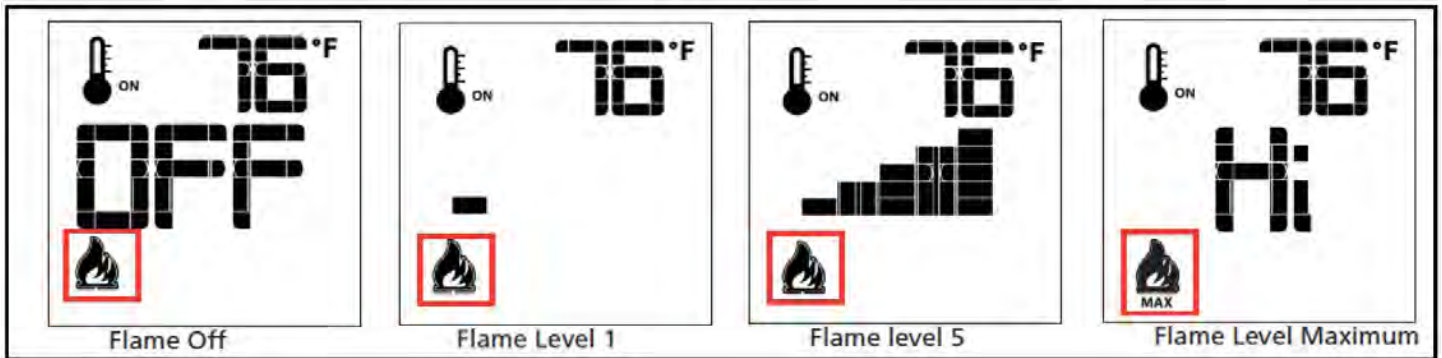

Figure 19.5.07:

Fan Speed Control

If the appliance is equipped with a hot air circulating fan, the speed of the fan can be controlled by the Proflame system. The fan speed can be adjusted through six (6) speeds. To activate this function use the Mode Key to index to the fan control icon. Use the Up/Down Arrow Keys to turn on, off or adjust the fan speed. A single "beep" will confirm reception of the command.

In manual mode the fan will activate immediately upon burner ignition. Adjust the fan speed to personal preference. Blower will shut off when the burner is extinguished.

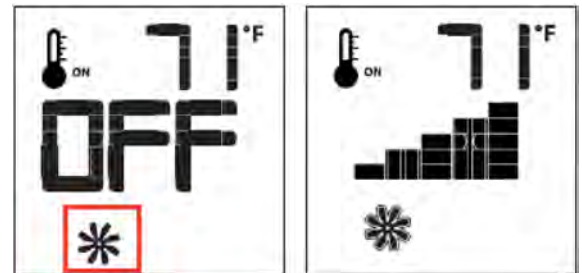

Figure 19.5.08:

Dimmer Control (Light)

This function is used to control the variable lights. To activate this function use the Mode Key to index to the variable light icon.

The intensity of the output can be adjusted through six (6) levels. Use the Up/Down Arrow Keys to adjust the output level. A single "beep" will confirm reception of the command.

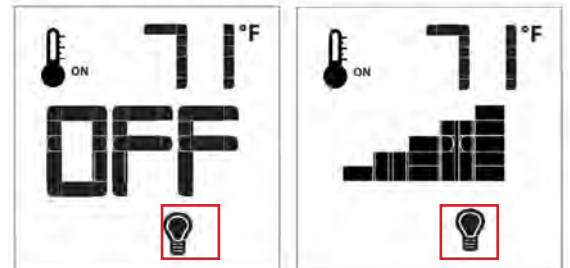

Figure 19.5.09:

Operation

Room Thermostat (Remote Operation)

The Remote Control can operate as a room thermostat. The thermostat can be set to a desired temperature to control the comfort level in a room.

To activate this function:

- Press the Thermostat Key. The LCD display on the remote will change to show that the room thermostat is “ON” and the set temperature is now active
- To adjust the temperature, press the Up/Down Arrow Keys until the desired temperature is displayed

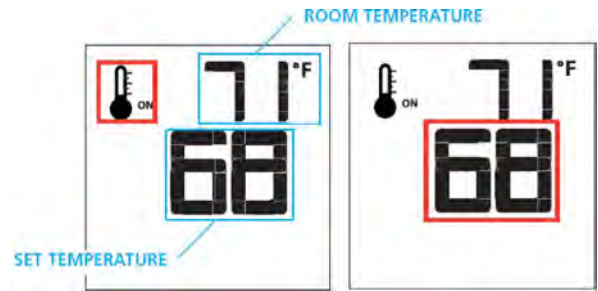

Figure 19.5.10:

SMART Thermostat (Remote Operation)

The Smart Thermostat function adjusts the flame height automatically in accordance to the difference between the set point and the actual room temperature. As the room temperature approaches the set point, the Smart Function will modulate the flame down.

To activate this function:

- Press the Thermostat Key until the word “SMART” appears to the right of the temperature bulb graphic
- To adjust the set temperature, press the Up/Down Arrow Keys until the desired set temperature is displayed

NOTE

When the fireplace is started in Smart Thermostat mode:

1. The fan will automatically activate 5min after ignition and shut down 12min after fire is turned off.
2. Manual Flame height adjustment is disabled.

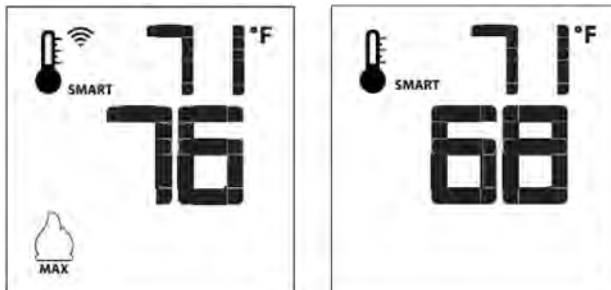

Figure 19.5.11:

Continuous Pilot on Demand / Intermittent Pilot (CPI/IPI) Selection

With the system in “OFF” position press the Mode Key to index to the CPI mode icon.

Pressing the UP Arrow Key will activate the Continuous Pilot on Demand Ignition mode (CPI). Pressing the Down Arrow Key will return to IPI. A single “beep” will confirm the reception of the command.

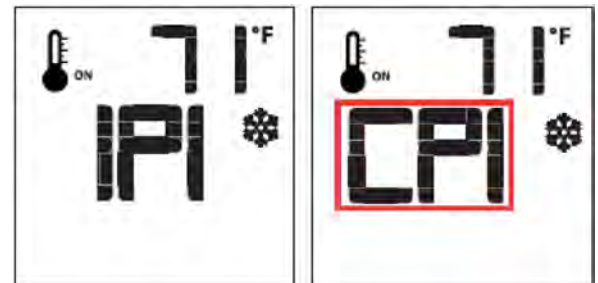

Figure 19.5.12:

CPI vs IPI:

Continuous Pilot on Demand Ignition (CPI): In this mode the pilot runs continuously even when the main burner is off. The Continuous Pilot on Demand Ignition operates on a seven day cycle. If the main burner is not turned on for seven continuous days, the pilot will turn itself off. When the main burner is lit again the cycle repeats. The pilot will remain lit for seven days, even after the main burner is turned off. If the main burner is lit during a seven day timing cycle, the seven day timer will reset.

Intermittent Pilot Ignition (IPI): A fuel saving mode in which the pilot is only used when the main burner is on.

This appliance is shipped in IPI mode. IPI mode is often the preferred method, however, there are some situations where it may be preferable to switch the fireplace into CPI mode. For example, in colder climates the glass door or the front of the fireplace could become very cold to the touch. Dynamic Start Advantage will solve most problems experienced by older IPI operated fireplaces.

Operation

Automatic Safety Shut-Off

This system will execute an automatic turn OFF command after a 24hr continuous main burner flame ignition. This allows the system to verify correct safety functions.

Diagnostic Indications Information

LOW BATTERY CONDITION (Less than 4V):

Remote Control

- Battery Icon will appear on LCD remote control display. Replace batteries.

Battery Back-up

- Red LED indicator will enter a (1) blink sequence. IFC Module will emit a double-beep when it receives an ON/OFF command from the hand held remote. Replace batteries.

Pilot Flame Error Condition:

- Red LED Indicator will commence a (2) blink sequence. Contact your dealer if this occurs.

System Lock Out Condition:

- Red LED Indicator will commence a (3) blink sequence. Make sure your gas is turned on.
- Make sure pilot sensor is not shorted out.
- If the system is in a locked state, reset the IFC module as follows: Turn off all power to the IFC module for at least 2 seconds (including the backup battery pack), then restore power to the IFC module.

Key Lock

This function will lock the keys to avoid unsupervised operation.

- To activate this function, press the MODE and UP Keys at the same time
- To deactivate this function, press the MODE and UP Keys at the same time



Figure 19.5.13:

Low Battery Power Detection (Less than 4V)

Remote

The life span of the remote control batteries depend on various factors:

- Quality of the batteries used
- The number of ignitions of the appliance
- The number of changes to the room temperature set point, etc

When the Remote batteries are low, a Battery Icon will appear on the LCD display of the Remote before all battery power is lost. When the batteries are replaced this icon will disappear.



Figure 19.5.14:

BACKUP BATTERY PACK (used when 120V home electrical power is interrupted):

- Red LED indicator on the IFC Module will enter a (1) blink sequence
- Backup batteries lifespan depends on various factors including battery quality, number of ignitions, changes to room thermostat set point, etc. When batteries are low, a double beep will be emitted from the IFC control module when it receives an ON/OFF command from the remote control
- This is an alert for a low battery condition of the backup batteries and after this double-beep warning, no commands will be accepted until batteries are replaced
- When batteries are replaced a beep will be emitted from IFC control module as soon as powered

20.0 Maintenance

CAUTION:

Do not conduct maintenance on the appliance while it is operating or while it is still hot. Always verify proper operation after servicing.

20.1 Cleaning and Routine Maintenance

The exterior painted surfaces, glass, and metal plated trims may be cleaned with a soft, non-abrasive cloth and water or a suitable, mild, non-abrasive cleaner. Be sure there are no fingerprints left on the glass panels as high temperatures can bake these prints on permanently.

Regularly:

- Frequent cleaning of the ceramic glass is recommended. We recommend using a good quality ammonia free gas fireplace glass cleaner that is available at any hearth retail location. Take care to avoid scratching glass while cleaning. **DO NOT CLEAN WHILE HOT.** Never use common household cleaners to clean the glass.
- Keep the appliance area free from combustible materials, such as paper, wood, clothing, gasoline and flammable solids, liquids and vapors
- Visually check the height and color of the burner and pilot flames.
- Touch up the paint if necessary using a high temperature metallic black paint. Allow the paint to dry prior to lighting the fireplace.

Once a year, have a qualified service technician:

- Perform the regular services listed above
- Inspect and operate the pressure relief mechanism (door buckles) to verify they are free from obstruction and operate properly
- Carefully remove the logs and gently brush off any loose carbon deposits. This job is best done outside the house, wearing a dust mask. The logs are very fragile, take care not to break them. Do not wash logs with any liquid. While the logs are removed, check that all burner openings are not obstructed and it is recommended you use a vacuum cleaner to clean off any dust or lint
- Vacuum and clean any lint accumulations or debris in the firebox, on the burners, on the pilot, at the primary air opening, on the convection air blower and in any combustion and convection air passageways
- After cleaning, the logs and embers must be replaced according to the instructions in this manual
- Inspect the operation of the flame safety system pilot and gas valve
- Inspect and ensure the lighting of the main burner occurs within 4 seconds of the main gas valve opening. Flames should match those shown in **Figure 20.5.01**
- Completely inspect the appliance and the venting system, if the vent pipe or seal is found to be defective, replace and or reseal (follow the instructions found in the venting instructions, **Section 13.0**)
- Inspect the condition of the vent and vent terminal for sooting or obstruction and correct if present
- Test and measure the flame failure response time of the flame safety system. It must de-energize the safety shutoff in no more than 30 seconds
- Check all accessible gas-carrying tubes, connections, pipes and other components for leaks

WARNING: All parts removed or disturbed, including guards and grills, must be properly replaced after maintenance. Service and repair must be conducted by a qualified service person. If these instructions are not followed, a fire or explosion may result, causing property damage, personal injury or loss of life.

20.2 Servicing Under Warranty

Before servicing, read the terms and conditions of the warranty at the back of this manual. Contact the authorized Archgard dealer where you purchased the appliance from and provide them with details of the problem, along with the initial installation information (from the front of this manual).

WARNING: Servicing of this appliance **must be conducted by a qualified Archgard service technician**. Improper servicing, adjustment or alteration of this appliance may cause property damage, personal injury or loss of life. All servicing should be conducted with the appliance cold. All replacement parts must be authorized by Archgard for suitability.

20.3 Checking Inlet and Outlet Pressure

1. Remove the surround.
2. The pressure test taps are located on the valve's front face. The inlet is marked 'IN' and the outlet is marked 'OUT'. See **Figure 20.3.01**.
3. Loosen the set screw inside the tap with a screwdriver.
4. Connect a 1/4" (6 mm) rubber tube to the tap post and a manometer.
5. Verify that the readings obtained are within specs (as shown on the appliance rating plate).
6. Be sure to tighten the set screw inside the tap after you have finished taking pressure readings.
7. Check for leaks.

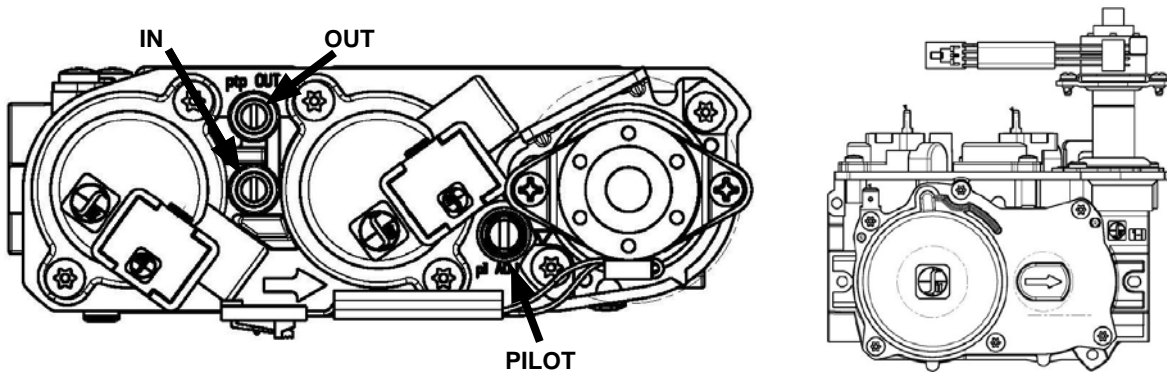

Figure 20.3.01

20.4 Checking and Adjusting Pilot

The pilot flames should have the characteristics shown in the illustration to the right.

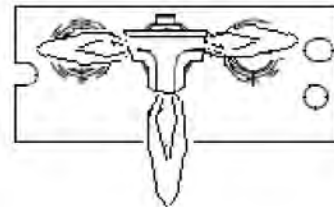

Figure 20.4.01

The flame should not have yellow tips but should engulf the flame sensor and spark electrode. It can be adjusted by turning the screw marked "pilot" on the control valve (See **Figure 20.3.01**).

It may be necessary to remove the pilot cover for a better view of the pilot flame (see next page).

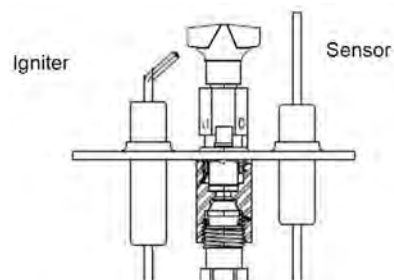

Figure 20.4.02

20.5 Adjusting the Primary Air

The 36-DVIE40LN-1 includes an air shutter located under the door of the fireplace which may be used to adjust the primary air to achieve the ideal flame as shown in **Figure 20.5.01**. To adjust, use a screwdriver to turn the air shutter adjustment screw as shown in **Figure 20.5.02**. To open the air shutter and increase air flow to the burner, turn the adjustment screw clockwise. To close the air shutter and decrease air flow to the burner, turn the adjustment screw counterclockwise.

CAUTION: Do not adjust primary air below specified opening on the rating plate.

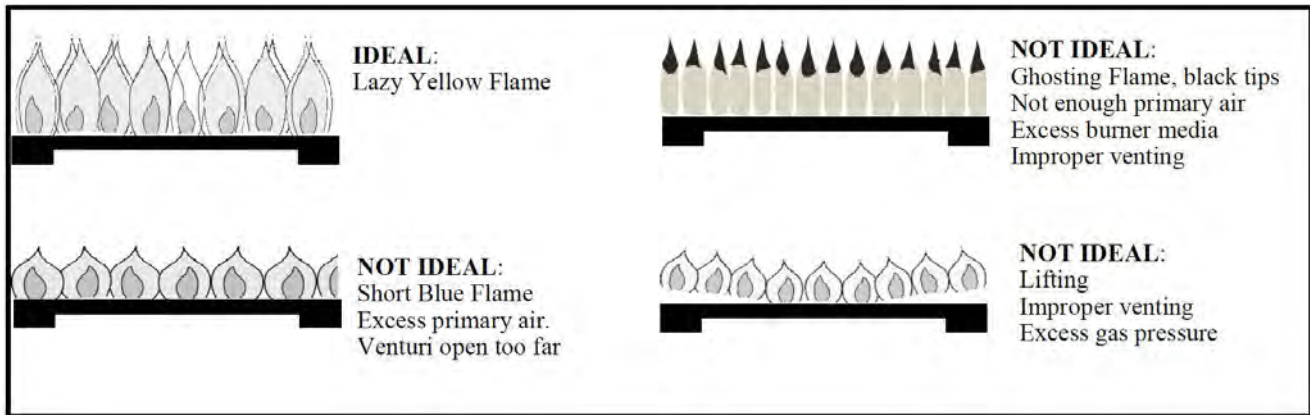

Figure 20.5.01:



Figure 20.5.02:

20.6 Replacing Batteries

1. Ensure the fireplace is off and cool before servicing.
2. Disconnect power supply to the fireplace.
3. Remove the fireplace surround.
4. Remove the battery holder from the velcro strip.
5. Remove the expired batteries and replace with a fresh set*.
6. Secure the battery holder in the velcro strip.
7. Replace the surround and resupply power.
8. Light the fireplace to verify proper operation.

Battery Specifications: 4 x AA Batteries

*Ensure batteries make contact at both ends of each battery.

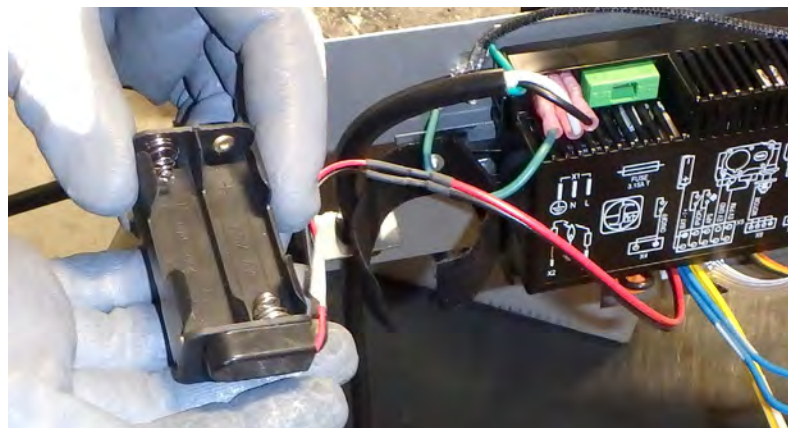

Figure 20.6.01:

20.7 Replacing Fuse

1. Ensure the fireplace is off and cool before servicing.
2. Disconnect power supply (including back-up battery power) to the fireplace.
3. Remove the fireplace surround.
4. Remove the fuse holder from the control board located on the right side of the fireplace.
5. Replace the fuse with one which has the same specifications using the existing fuse holder.
6. Replace surround and resupply power.
7. Light the fireplace to verify proper operation.

Fuse type: T3.15AL250V.

Archgard Part Number: RP-305-2080

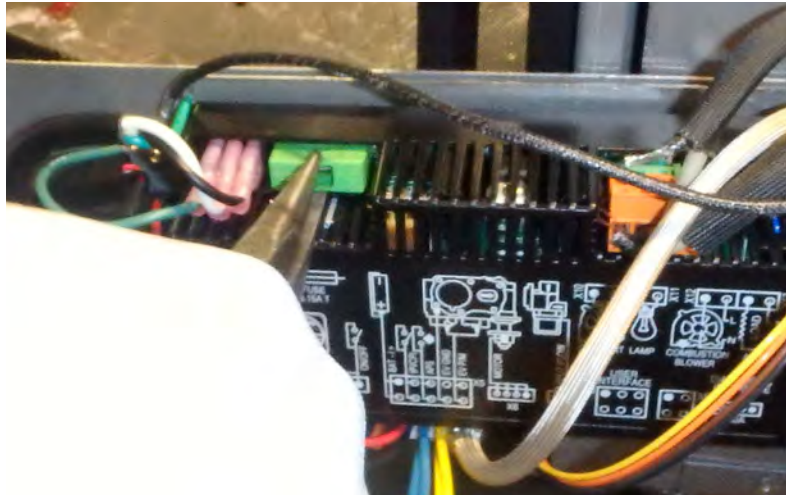

Figure 20.7.01:

20.8 Replacing Light Bulbs

Caution: Always handle bulbs with cotton gloves as finger prints may reduce the life of the bulb. We recommend replacing both bulbs at the same time.

1. Ensure the fireplace is off and cool before servicing.
2. Disconnect power supply (including back-up battery power) to the fireplace.
3. Turn off gas supply.
4. Remove the fireplace surround (optional).
5. Remove the barrier screen. See **Section 14.0**.
6. Remove the door assembly. See **Section 15.0**.
7. Pull the expired bulb to remove.
8. Replace with a bulb of the same specifications.
9. Ensure burner media has not been disturbed.
10. Replace door, barrier screen, and surround.
11. Resupply gas and power.
12. Light the fireplace to verify proper operation. See **Section 19.5** for information on using the remote to control the lights.



Figure 20.8.01:



Figure 20.8.02:

Bulb specification:	120V / 20W
	G6.35
	HALOGEN

20.9 Replacing the Control Board

CAUTION: Label all wires prior to disconnection when servicing controls. Wiring errors can cause improper and dangerous operation. Verify proper operation after servicing.
This appliance, when installed, must be electrically grounded in accordance with local codes or, in the absence of local codes, with the **National Electrical Code, ANSI/NFPA 70, or the Canadian Electrical code, CSA C22.1.**

Before you begin:

- Ensure the fireplace is off and cool before servicing.
 - Disconnect power supply (including back-up battery power) to the fireplace.
 - Remove the fireplace surround. See **Section 16.0.**
1. Label each wire as you disconnect them.
 2. Disconnect all connections to the control board.
 3. Remove nuts securing the control board at the top and bottom.
 4. Replace with the new control board and secure using nuts removed in the previous step.
 5. Reconnect all connections.
 6. Replace the fireplace surround.
 7. Supply power to the fireplace and verify proper operation.

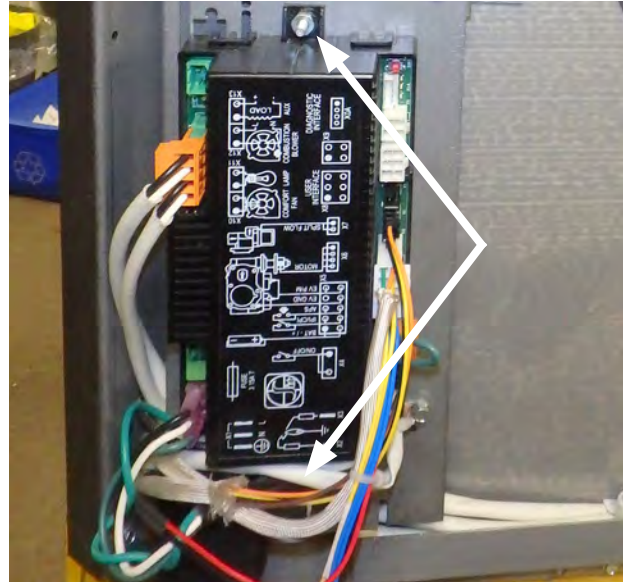

Figure 20.9.01:

20.10 Removing the Intake Restrictor

Before you begin:

- Ensure the fireplace is off and cool before servicing
- Disconnect power supply (including back-up battery power) to the fireplace
- Turn off gas supply
- Remove the fireplace surround. See **Section 16.0**
- Remove barrier screen. See **Section 14.0**
- Remove door assembly. See **Section 15.0**
- Remove burner media. See **Section 18.0**
- Remove panel set (if applicable). See **Section 17.0**
- Remove the burner. See **Section 20.11**

Step 1: Remove the (2) Tek screws securing the rear firebox panel.

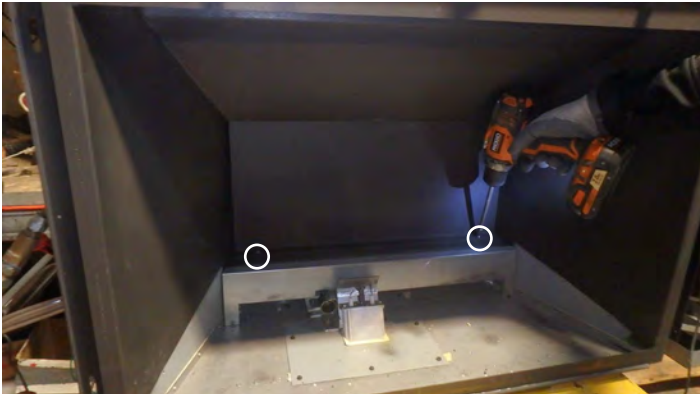

Figure 20.10.01:

Step 2: Remove the rear firebox panel.



Figure 20.10.02:

Step 3: Remove the (5) Tek screws securing the burner support bracket.

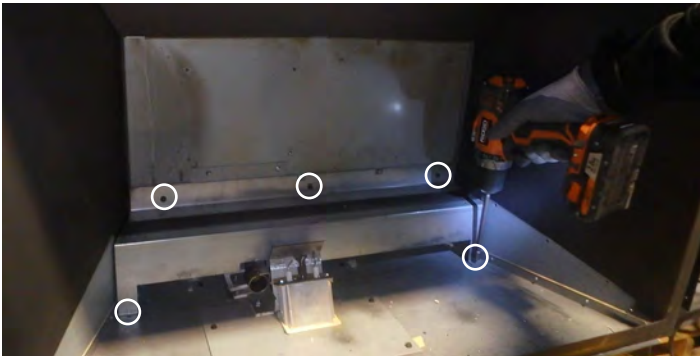

Figure 20.10.03:

Step 4: Remove the burner support bracket.



Figure 20.10.04:

Step 5: Remove the (4) Tek screws securing the restrictor plate and remove the plate.



Figure 20.10.05:

Step 6: Reinstall the (4) Tek screws that were removed in Step 5.

Step 7: Reinstall the burner support bracket and rear firebox panel.

Step 8: Reinstall the panel set, burner media, door assembly, barrier screen, and fireplace surround.

Step 9: Resupply gas and power. Verify proper operation.

20.11 Removing the Burner

Before you begin:

- Ensure the fireplace is off and cool before servicing
- Disconnect power supply (including back-up battery power) to the fireplace
- Turn off gas supply
- Remove the fireplace surround. See **Section 16.0**
- Remove barrier screen. See **Section 14.0**
- Remove door assembly. See **Section 15.0**
- Remove burner media. See **Section 18.0**
- Remove panel set (if applicable). See **Section 17.0**

Step 1: Remove the (5) Tek screws securing the ember strip at the front of the burner.



Figure 20.11.01:

Step 2: Remove the (9) Tek screws securing the burner.

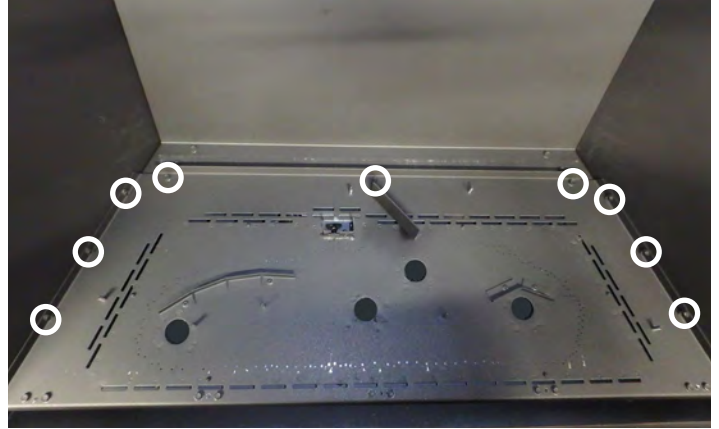

Figure 20.11.02:

Step 3: Carefully lift the burner up and away from the appliance.



Figure 20.11.03:

**Installation is the reverse of removal.
Test pilot and burner operation according to
Section 20.4 and Section 20.5.**

20.12 Removing the Pilot

CAUTION: Label all wires prior to disconnection when servicing controls. Wiring errors can cause improper and dangerous operation. Verify proper operation after servicing. This appliance, when installed, must be electrically grounded in accordance with local codes or, in the absence of local codes, with the **National Electrical Code, ANSI/NFPA 70, or the Canadian Electrical code, CSA C22.1.**

Before you begin:

1. Ensure the fireplace is off and cool before servicing
2. Disconnect power supply (including back-up battery power) to the fireplace
3. Turn off gas supply
4. Remove the fireplace surround. See **Section 16.0**
5. Remove barrier screen. See **Section 14.0**
6. Remove door assembly. See **Section 15.0**
7. Remove burner media. See **Section 18.0**
8. Remove panel set (if applicable). See **Section 17.0**
9. Remove the fireplace from the masonry opening (optional)
10. Remove the burner. See **Section 20.11**

Step 1: Remove the (2) screws securing the pilot shield. Remove the pilot shield from the fireplace.

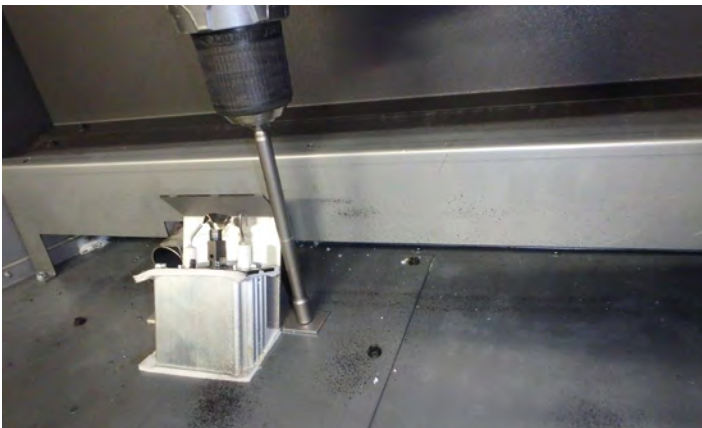

Figure 20.12.01:

Step 2: Remove the (2) screws securing the rear firebox panel.



Figure 20.12.02:

Step 3: Slide the bottom of the rear firebox panel outward to remove from the fireplace.



Figure 20.12.03:

Step 4: Remove the (5) screws securing the burner support bracket. Remove the burner support bracket from the fireplace.



Figure 20.12.04:

Maintenance

Step 5: Remove the (8) screws securing the fan to the back of the firebox. If preferred, remove the panel from the back of the fireplace.

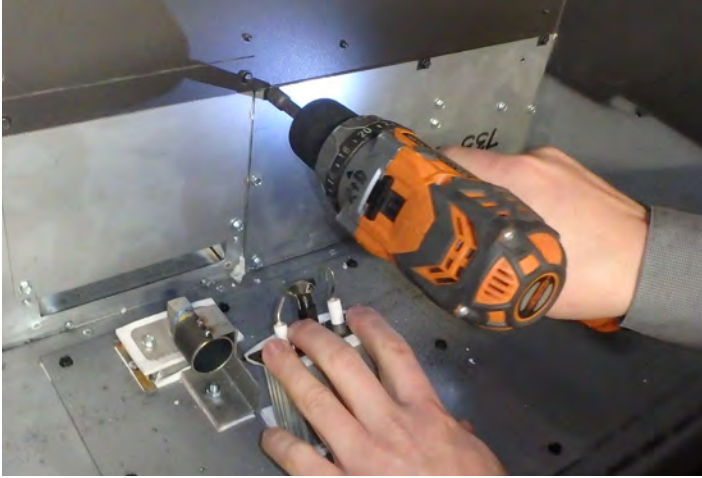

Figure 20.12.05:

Step 7: Remove the (2) screws securing the pilot.



Figure 20.12.07:

Step 9: Use a 7/16" wrench to detach the pilot gas line.



Figure 20.12.09:

Step 6: Unplug the fan while removing from the fireplace.

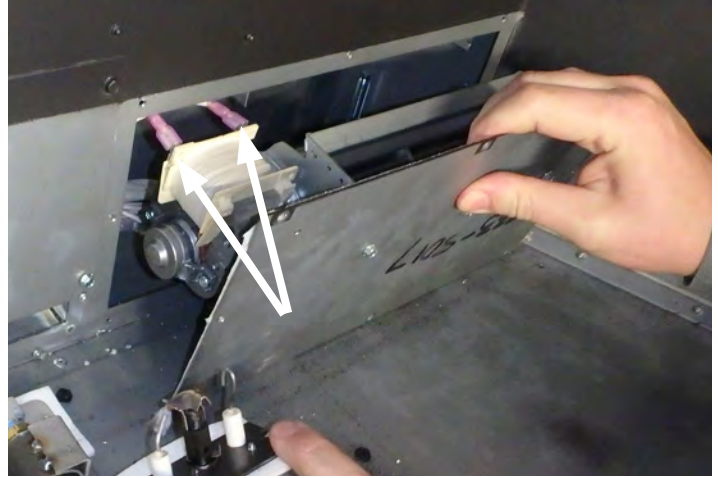

Figure 20.12.06:

Step 8: Remove the screw securing the pilot ground wire.



Figure 20.12.08:

Step 10: Unplug the pilot sensor and igniter wires from the control board.

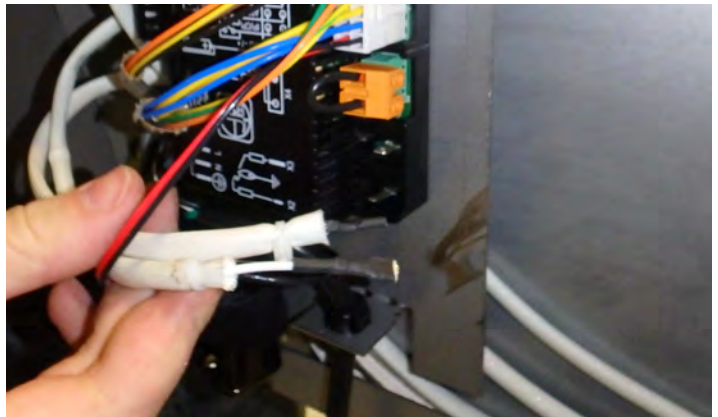

Figure 20.12.10:

Maintenance

Step 11: Snip the cable ties securing the wiring behind the firebox and remove the old pilot from the fireplace.

Step 12: Installation is the reverse of removal. Be sure to bundle wires using cable ties upon install.

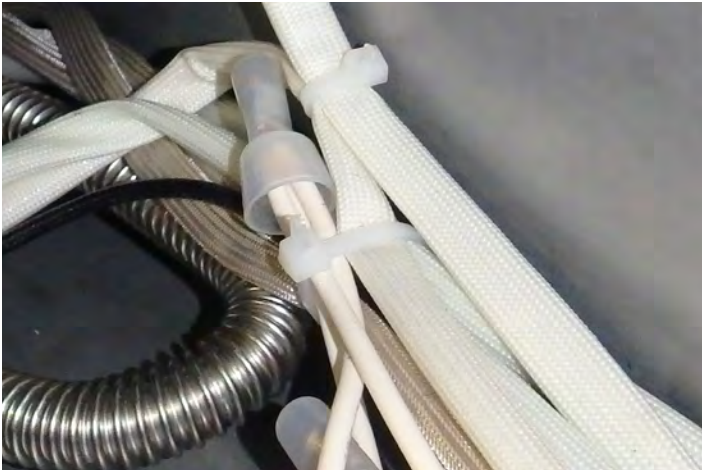

Figure 20.12.11:

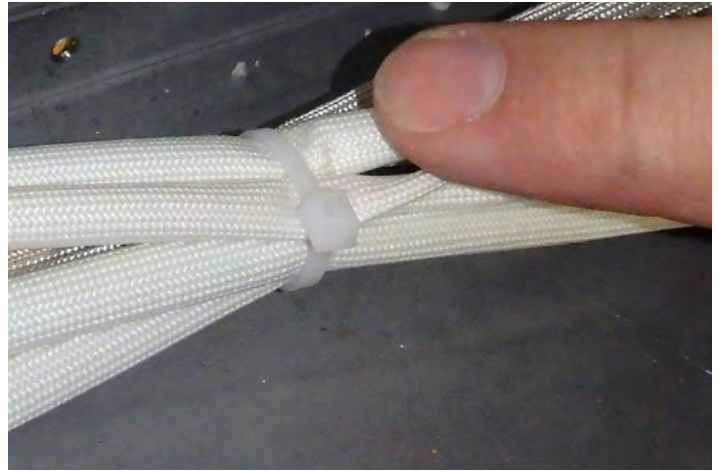

Figure 20.12.12:

IMPORTANT:

Ensure there are no gas leaks. Test the operation of the pilot and burner flames according to **Section 20.4** and **Section 20.5**.

If venting was disconnected be sure it is reinstalled according to the instructions in this manual.

20.13 Replacing the Fan

CAUTION: Label all wires prior to disconnection when servicing controls. Wiring errors can cause improper and dangerous operation. Verify proper operation after servicing. This appliance, when installed, must be electrically grounded in accordance with local codes or, in the absence of local codes, with the **National Electrical Code, ANSI/NFPA 70, or the Canadian Electrical code, CSA C22.1.**

Before you begin:

- Ensure the fireplace is off and cool before servicing
- Disconnect power supply (including back-up battery power) to the fireplace
- Turn off gas supply
- Remove the fireplace surround
- Remove barrier screen - See **Section 14.0**
- Remove door assembly - See **Section 15.0**
- Remove burner media - See **Section 18.0**
- Remove the burner - See **Section 20.11**

Step 1: Remove the (2) Tek screws securing the rear firebox panel.

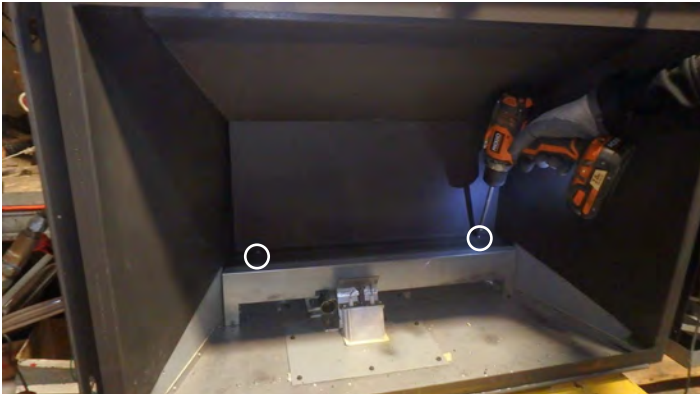

Figure 20.13.01:

Step 2: Remove the rear firebox panel.



Figure 20.13.02:

Step 3: Remove the (5) Tek screws securing the burner support bracket.

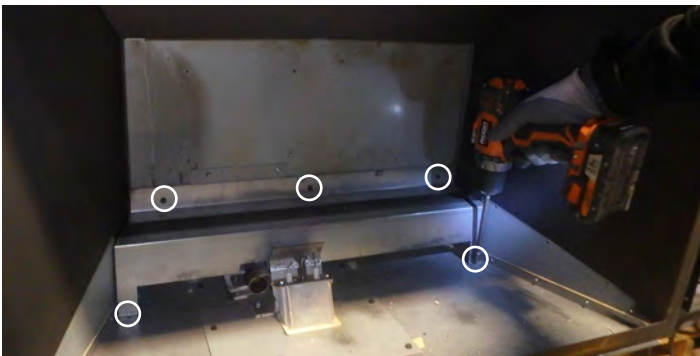

Figure 20.13.03:

Step 4: Remove the burner support bracket.



Figure 20.13.04:

Maintenance

Step 5: Remove the (8) screws securing the fan to the back of the firebox. If preferred, remove the panel from the back of the fireplace (see **Section 20.12**).

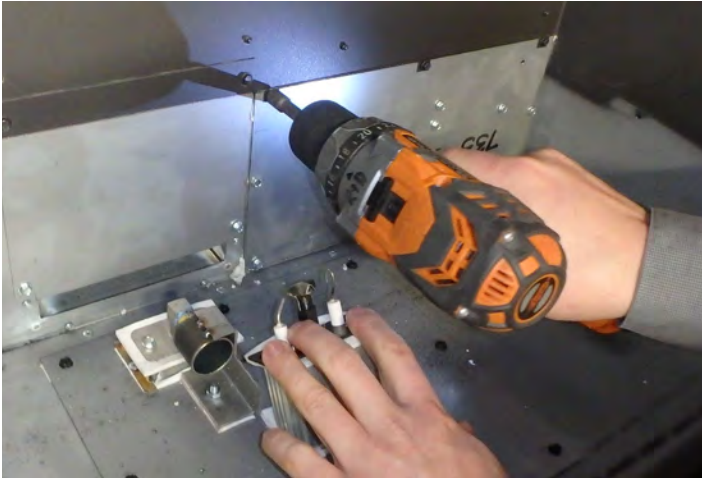

Figure 20.13.05:

Step 6: Unplug the fan while removing from the fireplace.

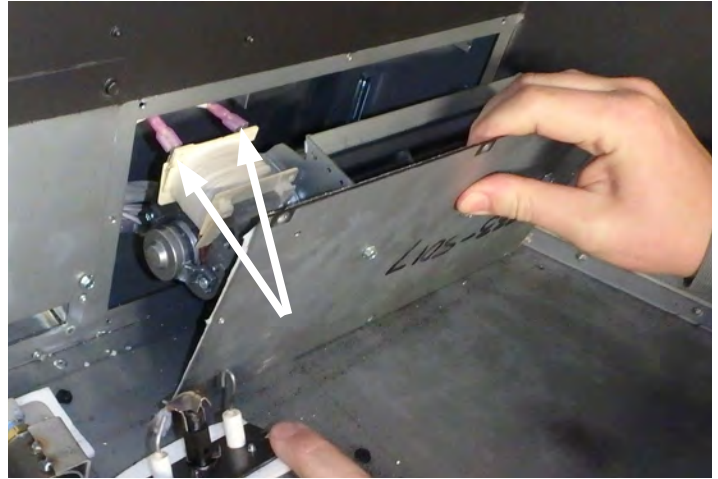

Figure 20.13.06:

Step 7: Remove the (4) screws securing the old fan to the fan bracket.

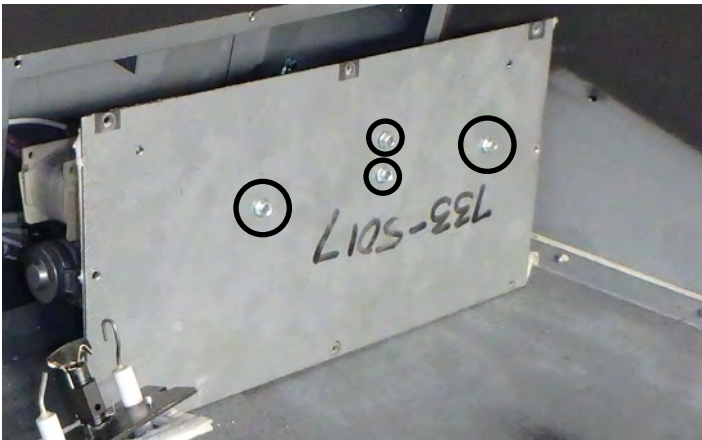

Figure 20.13.07:

Installation is the reverse of removal.

IMPORTANT:

Ensure there are no gas leaks. Test the operation of the fireplace according to instructions in this manual. If venting was disconnected be sure it is reinstalled according to the instructions in this manual.

20.14 Replacing Light Bases

CAUTION: Label all wires prior to disconnection when servicing controls. Wiring errors can cause improper and dangerous operation. Verify proper operation after servicing. This appliance, when installed, must be electrically grounded in accordance with local codes or, in the absence of local codes, with the **National Electrical Code, ANSI/NFPA 70, or the Canadian Electrical code, CSA C22.1.**

The steps below describe the process for replacing the left side light base in the **36-DVIE40LN-1**. The process is identical no matter which light base is being replaced. **Note:** we recommend replacing both light bulbs when replacing the light bases.

Before you begin:

- Ensure the fireplace is off and cool before servicing.
- Disconnect power supply (including back-up battery power) to the fireplace.
- Turn off gas supply.
- Remove the fireplace surround.
- Remove barrier screen. See **Section 14.0**
- Remove door assembly. See **Section 15.0**
- Remove burner media. See **Section 18.0**
- Remove panel set (if applicable). See **Section 17.0**
- Remove light bulbs. See **Section 20.8**
- Remove the fireplace from the masonry opening

Step 1: Remove the (12) Tek screws securing the rear fireplace panel.



Figure 20.14.01:

Step 2: Remove the (3) Tek screws securing the light wiring shield.

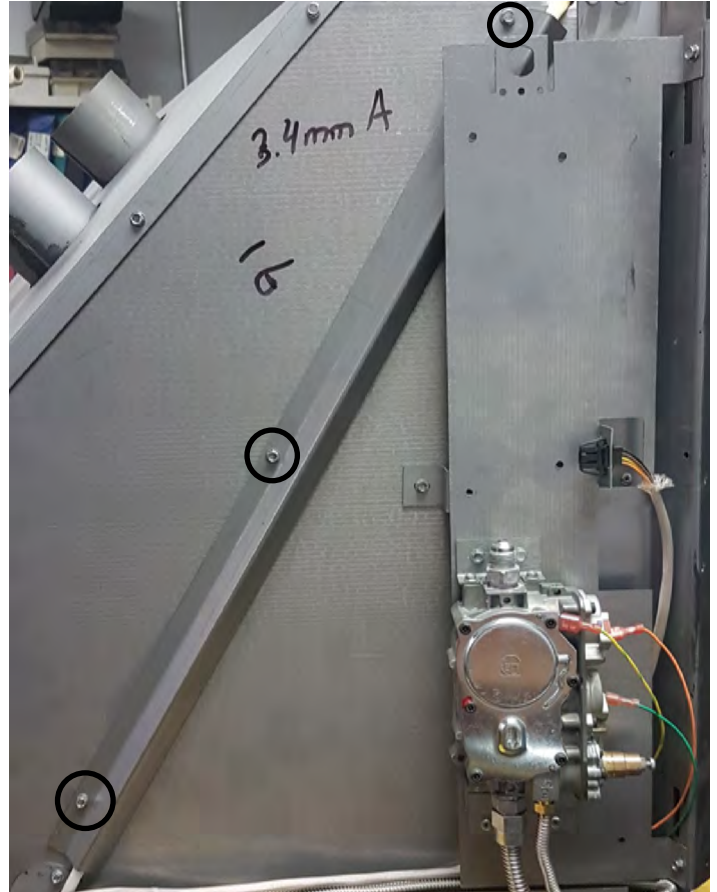

Figure 20.14.02:

Maintenance

Step 3: Unplug the light wire from the wiring harness.

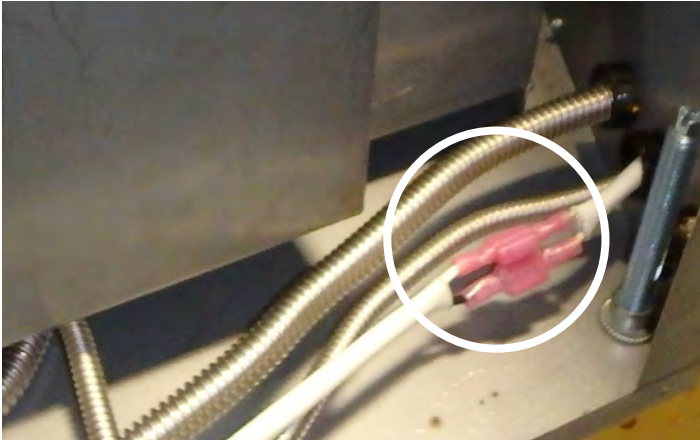

Figure 20.14.03: Wiring harness behind firebox.

Step 4: Remove the (4) Tek screws securing light base and bracket.



Figure 20.14.04:

Step 5: Remove the light base from the fireplace.



Figure 20.14.05:

Installation is the reverse of removal.

IMPORTANT:

Ensure there are no gas leaks. Test the operation of the fireplace according to instructions in this manual.
If venting was disconnected be sure it is reinstalled according to the instructions in this manual.

20.15 Wiring Schematic

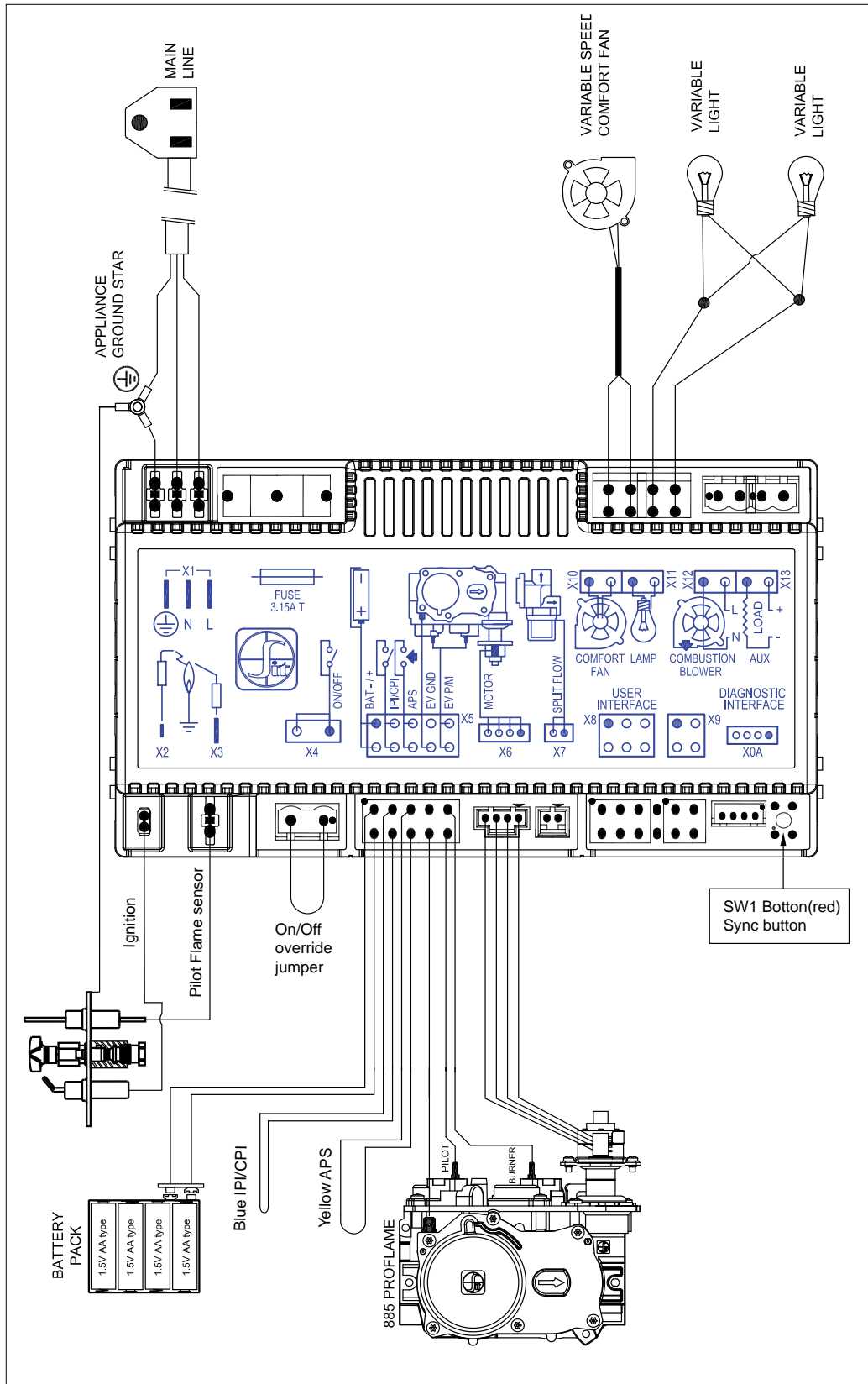

Figure 20.15.01

Maintenance

20.16 Troubleshooting

Issue	Solution
The pilot igniter won't spark.	<ol style="list-style-type: none"> 1. Ensure the ON/OFF override jumper is installed correctly. 2. Ensure main power is ON and new batteries are installed in the remote control (3 x AAA) and backup battery pack on the control board (4 x AA). 3. Make sure remote is synced with control board. 4. Check the 3.15A fuse in the control board. Replace the fuse if necessary. 5. Make sure remote is not in smart or thermostat mode. 6. Ensure igniter wire is connected to the control board and is not damaged.
The pilot igniter sparking, but the pilot will not light.	<ol style="list-style-type: none"> 1. Verify the inlet gas pressure is within acceptable limits. 2. Check all connections to the gas valve. 3. Ensure fuel supply valves and emergency shut-off valve are open. 4. Check wiring connections from control board to valve. 5. Check that the pilot is set to the correct fuel. 6. Ensure pilot head is clear of debris.
The pilot lights, but the main burner will not light.	<ol style="list-style-type: none"> 1. Check and verify all wiring connections match the wiring diagram. 2. Verify the inlet and manifold pressure are within acceptable limits.
The pilot lights, but the main burner will not light and igniter continues to spark.	<ol style="list-style-type: none"> 1. Check the pilot flame sensor rod and clean with steel wool or similar if dirty. 2. Check the pilot hood and clean with steel wool if dirty. 3. Ensure the flame sensor wire is plugged into the control board and is not damaged. 4. Adjust pilot flame using the pilot adjustment screw if the pilot flame is too long or too short (the flame should fully engulf the sensor rod and must be stable). 5. Check supply pressure. 6. Ensure the ground wire from the pilot is connected to the fireplace ground location.
The pilot was lit but will randomly go out.	<ol style="list-style-type: none"> 1. Turn the fireplace on again. If the fireplace is in continuous pilot on demand ignition mode, the system will turn off the pilot if the fireplace has not been used for seven days. You may also switch the fireplace to IPI mode (See Section 19.5). 2. Have a service technician check for low inlet pressure.
The flames on the main burner are low even though the remote is on high.	<ol style="list-style-type: none"> 1. Wait two minutes. Dynamic Start Advantage is designed to build a draft by starting on low and automatically increasing the flame size to the setting on the remote after two minutes. This system helps to create a better flame appearance, reduce condensation on the glass, and provide years of carefree operation. 2. Have a service technician check for low inlet pressure. 3. Replace the valve motor.
Fans do not work.	<ol style="list-style-type: none"> 1. Ensure main power is ON and the fireplace is plugged in (the fireplace may be operating on back up batteries). 2. Check the 3.15A fuse in the control board and replace if necessary. 3. Ensure the fans are connected to the control board.
Lights do not work.	<ol style="list-style-type: none"> 1. Ensure main power is ON and the fireplace is plugged in (the fireplace may be operating on back up batteries). 2. Check the 3.15A fuse in the control board and replace if necessary. 3. Ensure the lights are connected to the control board. 4. Replace the bulbs (bulbs may be burnt out).
Control module beeps twice when On/Off button on remote is pressed and Red LED is On.	<ol style="list-style-type: none"> 1. Replace batteries in remote battery pack.

All service and repairs should be performed by a qualified and licensed service technician.

21.0 Frequently Asked Questions

Listed below are some frequently asked questions regarding Archgard Gas Fireplaces. If you have questions that are not listed below, or are not answered in this manual, please contact your Authorized Archgard Dealer.

Q. My glass has a condensation “fog” when the appliance is first lit.

A. Condensation is normal and will disappear in a few minutes after the glass is heated. This can be reduced if the appliance is left in CPI mode.

Q. I have a white “film” on my glass. What is the best way to clean the inside of the glass.

A. Frequent cleaning of your glass is recommended. We recommend using a good quality “gas fireplace” glass cleaner that is available at all authorized dealers. Do not use abrasive materials, and do not clean the glass or the appliance when the unit is hot.

Q. How do I care for my plated trims.

A. We recommend a cleaning with a damp cloth. DO NOT use chemical cleaners as they may harm the finish, and void your warranty.

NOTE: If the top louvers, or top overlay starts to discolor, check the door gasket seal and contact your local Archgard dealer to replace if necessary.

Q. My fan/blower makes a “whirring” or “humming” noise.

A. Your Archgard gas appliance uses a powerful fan to push heated air into your room. It is not unusual to hear a “humming” noise when your fan is running. Note: the sound will change depending on the setting that your fan speed control is set at.

Q. I hear a “ticking”, “cracking” or “pinging” sound when my fireplace is running, and after it is turned off.

A. The different gauges of steel used to manufacture your fireplace will expand and contract at different rates when your fireplace is on, and will continue as your fireplace completes its heating function. You will likely hear these same sounds more on start up and shut down. This is normal for steel fireplaces.

Q. I hear a “click” when my main burner turns ON or OFF.

A. Your Gas Control Valve will make a clicking sound when it opens to allow gas to flow to the main burner. This is a normal part of the operating system.

Q. Can I burn wood and other materials in my gas fireplace.

A. No! Burning anything other than the fuel (natural gas or propane) the fireplace is setup for will create a potential fire hazard and present a danger to your home and its occupants and possibly void your manufacturer's warranty. Only burn the gas fuel for which the unit was originally designed.

Q. Can I shut my pilot off in the summer?

A. You will save energy by turning off the pilot light if you are not using your appliance for the hot summer months. When in continuous pilot ignition on demand (CPI) mode the pilot will remain lit for seven days after the fireplace is used. When seven days have passed the system will turn the pilot off. When in IPI mode, the pilot will only remain on when the main burner is on.

Q. Why does my fireplace start with a low flame? Shouldn't the flame size match the remote setting?

A. Dynamic Start Advantage was designed to create a draft by starting the fireplace on low and automatically increasing the flame to match the remote setting after two minutes. This system helps to create a better flame appearance, reduce condensation on the glass, and provide years of carefree operation.

Q. Can I position my gas logs in a different fashion or use a different log set?

A. No. Your gas fireplace is an engineered system that includes the firebox, burner, logs, venting and options which are tested and listed with a certification agency. Changing any specifications or placement of the logs could cause injury or damage, void your manufacturer's warranty, and possibly even your homeowner's warranty.

22.0 Replacement Parts List

Item #	Item Description	Unit
200-1920-11	Owner's Manual - English	EA
200-1920F-11	Owner's Manual - French	EA
36-BS	Barrier Screen	EA
308-6060	SIT Proflame II Dynamic Start Advantage with Continuous Pilot on Demand	EA
308-6027	SIT 885 Gas Valve c/w Step Motor	EA
308-6059-R2	Module Main Wiring Harness (5 wire)	EA
305-6316-R1	Valve Wiring Harness (4 wire)	EA
305-0060	Battery Back-up	EA
RP-305-2080	Fuse, 3.15A, 250V (Pack of 5)	EA
301-0068-30	Orifice - #30 DMS (3.26 mm) for Natural Gas	EA
301-0068-48	Orifice - #48 DMS (1.93 mm) for Propane	EA
308-0124	Pilot Assembly	EA
308-0125	PSE Spark Igniter	EA
308-0126	PSE Flame Sensor	EA
314-0139	Pilot Gasket	EA
301-6239	Pilot Gas Line	EA
RP-836-0040	Burner Assembly - Log Burner	EA
RP-836-0180	Light Base	EA
305-6314	Light Bulb (120V / 20W / G6.35)	EA
36-CKENG	Conversion Kit LP to NG	EA
36-CKELP	Conversion Kit NG to LP	EA
		EA
RF-305-0024	Replacement Fan	EA
310-6400-01	Complete Log Set (includes black embers)	SET
310-0019	Platinum Embers	EA
RP-836-0000	Complete Replacement Door. Includes glass, gasket and door frame	EA

Archgard Limited Warranty

This Limited Warranty is made by ARCHGARD INDUSTRIES LTD., hereinafter referred to as "Archgard". Archgard warrants to the original purchaser of an Archgard gas burning fireplace(s) that the product will be free from defects in materials and workmanship under normal use and service, for a "lifetime". All warranty repairs are to be performed by an authorized Archgard Dealer during the warranty period. Other repair / service company charges for any work done during the warranty period, will be the responsibility of the home owner.

INCLUSIONS: "LIFETIME LIMITED WARRANTY"

- All heat exchangers and combustion chamber
- Ceramic Fiber Logs and Ceramic Brick Panels, against splitting and cracking due to heat exposure

NOTE: Discoloration and some minor movement including warping of certain parts are normal and are not a defect; therefore, not covered under warranty.

INCLUSIONS: "SEVEN YEAR LIMITED WARRANTY"

- Burner tubes and pans

INCLUSIONS: "TWO YEAR LIMITED WARRANTY"

- Ceramic Glass against thermal breakage
- Trims and accessories from splitting or separating
- Electronic Control Module, Remote Transmitter

Items included with ten-year and two-year limited warranty will be covered under "Parts & Subsidized Labour" to the original purchaser for one (1) year and "Parts Only" thereafter from original date of purchase.

INCLUSIONS: "ONE YEAR LIMITED WARRANTY"

- Blowers, fans and fan motors, wiring, rheostats and thermodiscs
- Rocker switches, spill switches and wiring to them
- Gas control valves, pilot assemblies including thermopiles, thermocouples, electrodes and igniters
- Paint peeling or cracking

Items included in the one-year limited warranty will be covered under "Parts & Subsidized Labour" to the original purchaser for one (1) year from date of purchase.

WHAT TO DO IN THE EVENT OF A PROBLEM:

- Thoroughly read your "Owner's Installation, Operation & Maintenance Manual"
- If you cannot solve the problem, contact your Archgard dealer or representative
- When calling for assistance, please have the following information:

Model of your fireplace	Serial Number	Place of Purchase
Date of Purchase	Problem Description	

NOTE: Warranty will be void if work is carried out by an unqualified person(s). Only original Archgard parts may be used. Please consult your Archgard dealer or representative if in doubt about a replacement part(s).

- All warranty repairs are to be performed by an authorized Archgard Dealer during the warranty period. Other repair / service company charges for any work done during the warranty period, will be the responsibility of the home owner.

OBTAINING WARRANTY SERVICE:

The original purchaser shall return the defective part(s) to the original authorized Archgard dealer – transaction prepaid, along with the serial number of the appliance and original proof of purchase. Any defective part, in our judgment, will be repaired or replaced at Archgard's discretion. The dealer must obtain approval from Archgard before any repairs are made.

WARRANTY LIMITATION:

THIS LIMITED WARRANTY IS MADE IN LIEU OF ALL OTHER WARRANTIES, EXPRESSED OR IMPLIED AS TO QUALITY, MERCHANTABILITY OR FITNESS FOR PARTICULAR PURPOSE.

The appliance is only warranted for the use as intended by the installation and operating instructions and local building codes. The warranty will not cover damage due to accident, misuse, abuse, alteration, improper installation or "Acts of God". This limited warranty is void unless the appliance is installed by a qualified Archgard installer, in accordance with the instructions furnished with the appliance. Some Provinces or States do not allow limitations on how long an implied warranty lasts, so the above limitations may not apply to the original purchaser. Any damage resulting from defects in this product is limited to the replacement of the defective part(s) and does not include incidental and consequential exposures sustained in connection with the product. This includes facing(s), mantle(s), cabinet(s), tile(s) or any other finishes resulting from removal of any gas appliance. This warranty is limited to residential use only and gives the consumer specific rights. These rights may vary from State to State or Province to Province.

WARRANTY CONDITIONS & REQUIREMENTS:

1. You are the original purchaser – this warranty is not transferable.
2. Installation of the fireplace must be performed by a qualified Archgard installer.
3. Installation and operation must comply with the installation and operation instructions.
4. All optional accessories are covered for one (1) year from the date of purchase.
5. This warranty does not offer coverage for light bulbs or batteries (whether factory, dealer, or installer supplied). This includes any damage stemming from non-use.
6. Damage during shipping or handling of components, defects resulting from improper installation or service, or misuse of the fireplace or fireplace components are not covered under this warranty.
7. This warranty does not cover any part of the fireplace or any component which has been exposed to or submerged under water.
8. Archgard must be notified by the dealer the fireplace was purchased from or a qualified Archgard technician of the defect.
9. Annual service of the fireplace as required in the installation manual must be performed by a qualified Archgard technician (service records may be required to claim a warranty).
10. All previous warranty service must have been performed by a qualified Archgard technician (service records may be required to claim a warranty).
11. Travel time or mileage to the original purchaser's residences is not covered under this warranty. We suggest that you pre-arrange travel expenses with your Authorized Archgard Dealer.
12. Freight on warranty shall be covered for the first two years of the warranty period.

POSTAGE

WARRANTY REGISTRATION

ARCHGARD INDUSTRIES LTD.
PO BOX 318
RAYMOND, AB
T0K 2S0

CUT ALONG LINE

FOLD DOWN AT LINE

CUT ALONG LINE

FOLD DOWN AT LINE & TAPE CLOSED

Model # : 36-DVIE40LN-1 Serial #: _____ Date Installed: _____ / _____ / _____

Name: _____ Address: _____

City: _____ State/Prov: _____ ZIP: _____ Phone: (_____) _____

Dealer's Name & Address: _____

City: _____ State/Prov: _____ ZIP: _____ Phone: (_____) _____

Installer's Name & Address: _____

City: _____ State/Prov: _____ ZIP: _____ Phone: (_____) _____

Why did you choose this product? _____

CUT ALONG LINE

Thank you for purchasing our product and filling out this warranty card. Save time by completing this form at www.archgard.com/warranty-registration

ARCHGARD INDUSTRIES LTD.

300 RAILWAY AVENUE
RAYMOND, AB T0K 2S0
CANADA

WWW.ARCHGARD.COM