



INSTALLATION, OPERATION, AND MAINTENANCE MANUAL

Chantico 27

Model: 27-DVIE22N-2
 GAS FIRED DIRECT VENT
 FIREPLACE INSERT
 S/N 272150 AND UP



This appliance may be installed in an aftermarket permanently located, manufactured home (USA only) or mobile home where not prohibited by local codes.

This appliance is only for use with the type of gas indicated on the rating plate. This appliance is not convertible for use with other gases, unless a certified kit is used.

WARNING: If the information in these instructions is not followed exactly, a fire or explosion may result, causing property damage, personal injury or loss of life.

WARNING: If the information in this manual is not followed exactly, a fire or explosion may result causing property damage, personal injury or loss of life.

Do not store or use gasoline or other flammable vapors or liquids in the vicinity of this or any other appliance.

WHAT TO DO IF YOU SMELL GAS:

- Do not try to light any appliance
- Do not touch any electrical switch; do not use any phone in your building
- Immediately call your gas supplier from a neighbors phone.
- Follow the gas suppliers instructions
- If you can not reach your gas supplier, call the fire department

Installation and service must be performed by a qualified installer, service agency or the gas supplier.

English and French Installation Manuals available through your local dealer or visit our website at: www.archgard.com
 Les manuels d'installation en anglais et en français son disponibles chez votre détaillant local ou en visitant notre site web: www.archgard.com

INSTALLER: LEAVE THIS MANUAL WITH THE APPLIANCE.
CONSUMER: RETAIN THIS MANUAL FOR FUTURE REFERENCE.

DANGER



HOT GLASS WILL CAUSE BURNS.
DO NOT TOUCH GLASS UNTIL COOLED.
NEVER ALLOW CHILDREN TO TOUCH GLASS.

A barrier designed to reduce the risk of burns from the hot viewing glass is provided with this appliance and must be installed for the protection of children and other at-risk individuals.



We recommend that our gas hearth products be installed and serviced by professionals who are certified in the U.S. by the National Fireplace Institute® (NFI) as NFI Gas Specialists.

ARCHGARD FIREPLACE PRODUCTS

300 Railway Avenue
 Raymond, AB T0K 2S0 Canada

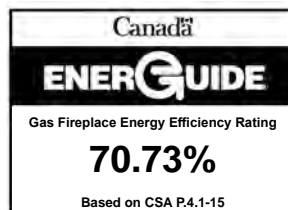

Gas Fireplace Energy Efficiency Rating
70.73%
 Based on CSA P.4-1-15



200-1127-17
 February 18, 2026

TABLE OF CONTENTS

1.0 Introduction	3	16.0 Surround Installation	29
2.0 Safety Information	4	16.1 Surround Dimensions.....	30
3.0 Technical Information	5	16.2 Trimmable Surround Dimensions.....	31
3.1 Appliance Certification.....	5	16.3 Dimensions of Fronts.....	32
3.2 Installation Codes.....	5	16.4 Decorative Trim Dimensions.....	33
3.3 Specifications.....	5	16.5 Decorative Plinth Dimensions.....	34
3.4 High Altitude Installation.....	5	17.0 Firebox Liner Installation	35
4.0 Rating Plate	6	17.1 Brick Panel Installation.....	35
5.0 Installation Checklist	7	18.0 Media Installation	37
6.0 Appliance Overview	8	18.1 Log Set.....	37
6.1 Rating Plate Location.....	8	18.2 Ember Placement.....	40
6.2 Appliance Overview.....	8	18.3 Complete Log Set.....	42
6.3 Leveling the Appliance.....	9	19.0 Operation	43
7.0 Electrical Connections	9	19.1 Before Lighting.....	43
8.0 Appliance Dimensions	10	19.2 First Fire.....	43
8.1 Control Panel Locations.....	10	19.3 Lighting Instructions.....	44
9.0 Minimum Opening Dimensions	12	19.4 Dynamic Start Advantage.....	45
9.1 Factory Built Fireplaces.....	13	19.5 Remote Control Operation.....	46
9.2 Refacing a Masonry Fireplace.....	14	20.0 Maintenance	53
10.0 Clearances to Combustibles	15	20.1 Cleaning the Appliance.....	53
10.1 Mantel Clearances.....	15	20.2 Servicing Under Warranty.....	54
10.2 Sidewall Clearances.....	15	20.3 Checking Inlet and Outlet Pressure.....	54
10.3 Hearth Clearances.....	16	20.4 Checking and Adjusting Pilot.....	54
10.4 Heat Sensitive Flooring Materials.....	17	20.5 Adjusting the Primary Air.....	55
11.0 Gas Connections	18	20.6 Replacing Batteries.....	55
11.1 Clocking Procedure.....	18	20.7 Replacing Fuse.....	55
12.0 Conversion Kit Instructions	19	20.8 Replacing the Control Board.....	56
12.1 Prepare the Fireplace.....	19	20.9 Replacing the Valve.....	57
12.2 Pilot Conversion.....	19	20.10 Replacing the Burner.....	58
12.3 Convert the Gas Valve.....	20	20.11 Replacing the Pilot.....	59
12.4 Complete the Conversion.....	20	20.12 Replacing the Fan.....	62
13.0 Venting Instructions	21	20.13 Wiring Schematic.....	64
13.1 Approved Terminations.....	22	20.14 Troubleshooting.....	65
13.2 Min/Max Vent Run.....	24	21.0 Frequently Asked Questions	66
13.3 Using a Co-linear to Coaxial Adapter.....	25	22.0 Replacement Parts List	67
14.0 Barrier Screen Installation	27		
15.0 Glass Door Installation	28		
15.1 If Your Glass Breaks.....	28		

General Information

1.0 Introduction

Thank You and Congratulations for choosing an Archgard Gas Fireplace insert!

Chantico (Chan-TEE-ko) - "she who dwells in the house" is the Aztec deity reigning over the fires in the family hearth. She was the goddess of pleasure and the home, the place where families gather. Ancient Aztecs prayed to Chantico to bestow wealth and stability upon their homes and men who were going off to battle would pray to her that they would return and find those home fires burning.

The Chantico 27 is one of the most advanced Direct Vent Insert heaters available today. It is solidly designed using the latest technology and manufactured to the highest quality. It is our aim to provide you with an appliance that brings many trouble-free years of reliable service. This manual provides information regarding model number 27-DVIE22N-2.

Some of the many features of your 27-DVIE22N-2 are:

- **Heater Classification** This fireplace is classified as a heating appliance. Therefore, it uses Direct Vent safety technology and it is suitable for continuously operated zone heating.
- **High Efficiency** This fireplace has one of the highest efficiencies of any Direct Vent gas insert, ensuring it is less expensive to operate.
- **Adjustable Fan Speed** This fireplace comes complete with an adjustable six speed circulation fan controlled with the remote.
- **Adjustable Flame** This fireplace provides the ability to adjust the flame aesthetics and heat output to suit the owner's liking and heating needs.
- **Solid Construction** This fireplace is mainly constructed of 16 and 18 gauge galvanized and aluminized coated steel for long life and durability.
- **Optional Accessories** Speak with your local Authorized Archgard Dealer for a full complement of decorative accessories to suit your home's decor and personal tastes.
- **Electronic Control System** This fireplace comes standard with the Dynamic Start Advantage. This new electronic ignition system is the latest in fireplace technology. It helps to create a better draft, better flame appearance, less condensation on the glass, and years of carefree operation. See **Section 19.4** for complete explanation of how the system works.
- **Multiple Electronic Pilot Settings** This fireplace uses a gas control valve that is operated by a Multifunction Remote Control. It can be set up as either an Intermittent Pilot Ignition (IPI) system, or Continuous Pilot on Demand Ignition (CPI) system (also known as a Pilot on Demand (POD)).

Model Number Definition (27-DVIE22N-2)

27	Diagonal dimension of the fireplace opening in inches
DVI	Direct Vent Insert
E	Electronic Ignition
22	Natural Gas Input Rating in BTU
N	Traditional Log Set
-2	Revision Number

CPI vs IPI:

Continuous Pilot on Demand Ignition (CPI): In this mode the pilot runs continuously even when the main burner is off. The Continuous Pilot on Demand Ignition operates on a seven day cycle. If the main burner is not turned on for seven continuous days, the pilot will turn itself off. When the main burner is lit again the cycle repeats. The pilot will remain lit for seven days, even after the main burner is turned off. If the main burner is lit during a seven day timing cycle, the seven day timer will reset.

Intermittent Pilot Ignition (IPI): A fuel saving mode in which the pilot is only used when the main burner is on.

This appliance is shipped in IPI mode. IPI mode is often the preferred method, however, there are some situations where it may be preferable to switch the fireplace into CPI mode. For example, in colder climates the glass door or the front of the fireplace could become very cold to the touch. Dynamic Start Advantage will solve most problems experienced by older IPI operated fireplaces.

Please complete and submit the warranty registration card included in the back of this manual or by visiting us at:
www.archgard.com/warranty-registration

General Information

2.0 Safety Information

Caution

FOR YOUR SAFETY - Do not install or operate your 27-DVIE22N-2 without reading and understanding this manual. Any installation or operational deviation from this instruction manual voids the warranty and may prove hazardous.

This appliance must be installed by a qualified gas installer and the installation must conform to the installation codes.

Provide adequate clearance around air openings into combustion chamber.

Never obstruct front openings.

Provide adequate clearances for proper operation and servicing of the appliance.

This appliance must be properly connected to an approved venting system and must not be connected to a chimney flue serving a separate solid fuel burning appliance.

Flow of combustion and ventilation air must not be obstructed.

Always provide adequate clearance around the intake and exhaust openings.

Safety

Due to high temperatures, the appliance should be located out of traffic and away from furniture and draperies.

Children and adults should be alerted to the hazards of high surface temperature and stay away to avoid burns or clothing ignition.

Young children should be carefully supervised when they are in the same room as the appliance. Toddlers, young children and others may be susceptible to accidental contact burns. A physical barrier is recommended if there are at risk individuals in the house. To restrict access to a fireplace or stove, install an adjustable safety gate to keep toddlers, young children and other at risk individuals out of the room and away from hot surfaces.

Do not store or place combustibles, gasoline, and other flammable vapors and liquids near the appliance.

Clothing or other flammable material should not be placed on or near the appliance.

Do not operate with cracked or broken glass. Do not strike or slam the glass.

WARNING: Do not operate appliance with the glass front removed, cracked, or broken. Removal of the glass should be done by a licensed or qualified service person.

Any safety screen or guard removed for servicing an appliance must be replaced prior to operating.

Installation and Repair should be done by a qualified service person. The appliance should be inspected before use and at least annually by a professional service person. More frequent cleaning may be required due to excessive lint from carpeting, bedding materials, etc. It is imperative that the control compartments, burners and circulating air passageways of the appliance are kept clean.

Do not use this appliance if any part has been under water. Immediately call a qualified service technician to inspect the appliance and to replace any part of the control system and any gas control which has been under water.

California Proposition 65 Warning: This product can expose you to chemicals including Carbon Monoxide, that is an externally vented by-product of fuel combustion, which is [are] known to the State of California to cause cancer, birth defects, or other reproductive harm. For more information, visit www.P65Warnings.ca.gov.

Each Archgard Gas Fireplace is checked and tested at the factory prior to being packaged and shipped to our dealers and finally installed in your home. Before leaving this unit with the customer, the installer must ensure that the appliance is firing correctly and that the electrical system is in working order. The Installation Checklist in **Section 5.0** should be used to ensure the proper installation of this gas fireplace insert and to document any deviations from a typical install.

Any alteration to the product that causes carbon or soot deposits that results in any damage or requires cleaning is not the responsibility of the manufacturer.

General Information

3.0 Technical Information

3.1 Appliance Certification

This appliance was listed by QAI Laboratories, Inc. to the following USA and Canadian gas appliance standards.

- ANSI Z21.88-2019 / CSA 2.33-2019 Vented Gas Fireplace Heaters
 - CAN/CGA-2.17-M91(R2009), Gas-Fired Appliances for Use at High Altitudes
 - CSA P.4.1-15 testing method for measuring annual fireplace efficiency
 - CSA C22.2 No.3 - M1998(R.2014) - Electrical Features of Fuel-Burning Equipment
- The listing label is attached to the appliance on the bottom right side of the appliance.
A copy is shown on **Section 4.0**.

Commonwealth of Massachusetts: This appliance has been manufactured in accordance with Massachusetts code 248 CMR 5.00. Approval Code: G1-0717-621. (<http://license.reg.state.ma.us/public/licque.asp>).

Please contact **Archgard Industries Ltd.**, if you have any questions regarding the certification of this appliance.

3.2 Installation Codes

This appliance must be installed by a qualified gas appliance installer. The installation must conform with the local codes or, in the absence of local codes, with the current National Fuel Gas Code ANSI Z223.1/ NFPA 54 in the US, or Installation Code CAN/CGA-B149.1 in Canada. Electrical connections and grounding must conform with local code, or current National Electrical code ANSI/NFPA No. 70-1987 in the US, and in Canada the current Canadian Electrical Code CSA C22.1.

We recommend that our gas hearth products be installed and serviced by professionals who are certified in the U.S. by the National Fireplace Institute® (NFI) as NFI Gas Specialists.

3.3 Specifications

	Natural Gas (NG)	Propane (LP)
Manifold Pressure	1.6 - 3.5 in. W.C. (0.4 - 0.9 kPa)	6.4 - 10.0 in. W.C. (1.6- 2.5 kPa)
Min. Supply Pressure	5.0 in. W.C. (1.2 kPa)	11.0 in. W.C. (2.8 kPa)
Max Supply Pressure	14.0 in. W.C. (3.5 kPa)	14.0 in. W.C. (3.5 kPa)
Orifice Size	#43 DMS (2.25 mm dia)	#54 DMS (1.36 mm dia)
Input Rating	15,000 - 22,400 BTU/h (4.5 - 6.56kW)	16,500 - 21,000 BTU/h (4.8 -6.15kW)
P.4 Fireplace Efficiency (FE)	70.73%	70.73%
P.4 Steady State Efficiency	73.19%	73.19%
Electrical Rating	120 VAC, 60Hz less than 2 A.	
Gas Control	SIT 885 Proflame II Dynamic Start Advantage with Continuous Pilot on Demand	
Altitude	0 - 4,500 ft. (0 - 1372 M)	0 - 4,500 ft. (0 - 1372 M)
Primary Air Opening	1/4" (6 mm) OPEN	FULLY OPEN

3.4 High Altitude Installation

When installing this appliance beyond 4500 ft. (1372 M) above sea level, the appliance must be properly derated and installed according to local codes, in the absence of local codes, with the current National Fuel Gas Code, ANSI Z223.1/ NFPA 54, in the US or Installation Code, CAN/CGA-B149.1, in Canada.

General Information

4.0 Rating Plate

DO NOT REMOVE THIS LABEL



MODEL: 27-DVIE22N-2
Manufactured as Natural Gas

VENTED GAS FIREPLACE HEATER and GAS-FIRED APPLIANCES FOR USE AT HIGH ALTITUDES.
Tested to: ANSI Z21.88-2019 / CSA 2.33-2019, CAN/CGA 2.17-M91 (R2009), CSA – P.4.1-15, CSA C22.2 No.3 – M1988(R.2014).
This vented gas fireplace heater is not for use with air filters. Certified for use in both CANADA and USA.
VENTED GAS FIREPLACE HEATER-NOT FOR USE WITH SOLID FUEL.

	NG	LPG
Input rating	15,000 - 22,400 BTU/hr (4.54 - 6.56 kW)	16,500 - 21,000 BTU/hr (4.84 - 6.15 kW)
Manifold Pressure	1.6 - 3.5 in. W.C. (0.4 - 0.9 kPa)	6.4 - 10.0 in. W.C. (1.6 - 2.5 kPa)
Orifice size	#43 DMS (2.26 mm dia.)	#54 DMS (1.397 mm dia.)
Minimum supply pressure for purpose of input adjustment.	5.0 - 14.0 in. W.C. (1.2 - 3.5 kPa)	11.0 - 14.0 in. W.C. (2.8 - 3.5 kPa)
Burner Primary Air Setting	1/4" (6mm) Open	100% Open
Altitude	0 - 4500 ft (0 - 1372 m)	0 - 4500 ft (0 - 1372 m)
Gas Control	SIT 885 Inlet flame II Dynamic Start with Continuous POD	
Electrical rating	120 VAC 60 Hz less than 2 A.	
P.4.1 Fireplace Efficiency (FE)	70.73%	
Replacement fan	Part no. RF-305-0024 fan or blower assembly must be used	
Keep burner and control compartment clean. See instructions accompanying the heater.	Minimum opening Dimensions: 17.125" (435 mm)W x 17.928" (455.4 mm)H x 14.375" (365.1 mm)D	
Optional fuel conversion kit : See Manual.	Minimum Chimney Flue Size: 4" (100 mm) x 7" (176 mm) Minimum clearances to Combustibles: Sides from glass door frame: 8" (203 mm) Mantle: max 12" (305 mm) at min 33" (838 mm) from hearth See Manual for additional dimensions and clearances	

This appliance must be installed in accordance with local codes, if any; if none, follow the National Fuel Gas Code, ANSI Z223.1/NFPA 54, or Natural Gas and Propane Installation Codes, CSA B149.1. Electrical connections and grounding must be in accordance with local codes, if any; if none, follow the current CAN/CSA C22.1 in Canada and ANSI/NFPA 70 in the US. This appliance is certified for installation in a bedroom or a bed sitting room. This appliance is only for use with the gas indicated on the rating plate and may be installed in an aftermarket, permanently located, manufactured (mobile) home where not prohibited by local codes. See owner's manual for details. This appliance is not convertible with other gases, unless a certified kit is used.

WARNING: Improper installation, adjustment, alteration, service, or maintenance can cause injury or property damage. Refer to the owner's information manual provided with this appliance. For assistance or additional information consult a qualified installer, service agency, or the gas supplier. This appliance must be properly connected to a Direct Vent venting system in accordance with the manufacturer's installation instructions.

WARNING: Failure to install this appliance per the manufacturer's instructions or failure to use only parts specifically approved with this appliance may result in property damage or personal injury.

WARNING: Do not operate the appliance until all sections have been assembled and installed in accordance with the manufacturer's instructions.



WARNING: Operation of this appliance when not connected to a properly installed and maintained venting system can result in carbon monoxide (CO) poisoning and possible death.

ONLY DOORS CERTIFIED WITH THE APPLIANCE SHALL BE USED.
For use only with barrier part # 27-BS. Follow installation instructions.

Made in Canada by:
Archgard Industries Ltd.
300 Railway Avenue, Raymond, AB

October 2024 303-6027-10

MANUFACTURE DATE:

Installation

5.0 Installation Checklist

This standard installation checklist is to be used by the installer in conjunction with, not instead of, the instructions contained within this installation manual.

Customer: _____ Install Address: _____	Date Installed: _____ Location of Fireplace: _____ Installer: _____
---	--

Solid Fuel Zero Clearance Install: (Section 9.1)	YES	NO	IF NO, WHY NOT?
Was the bottom of the existing zero clearance removed?			
Venting: (Section 13.0)			
	YES	NO	IF NO, WHY NOT?
Venting configuration complies with vent diagrams.			
Venting installed, fastened, and secured in place maintaining proper clearances.			
Secured or removed existing solid fuel fireplace damper.			
Terminations installed and sealed in compliance with local building code.			
Direct vent termination is highest point in vent assembly.			
Wiring / Electrical: (Section 7.0)			
	YES	NO	IF NO, WHY NOT?
Connected to household 110/120v per local codes.			
Unit is properly grounded.			
Gas: (Section 11.0)			
	YES	NO	IF NO, WHY NOT?
Proper appliance for fuel type?			
Was a conversion performed?			
Leak check performed & inlet and manifold pressures verified?			
Was the rating of the insert clocked?			
Finishing:			
	YES	NO	IF NO, WHY NOT?
Only noncombustible material installed in noncombustible areas.			
Clearances meet installation manual requirements.			
Mantels and/or projections comply with install manual.			
Was the solid fuel fireplace warning plate installed (Figure 9.0.02)?			
Appliance Setup:			
	YES	NO	IF NO, WHY NOT?
Burner media / log set, door, and screen installed according to install manual.			
Manual given to home owner.			
Did you check operation of fans, and flame modulation?			
Comments:			

6.0 Appliance Overview

6.1 Rating Plate Location



Figure 6.1.01:

6.2 Appliance Overview

The Proflame II control board is located on the right side* of the fireplace behind the surround.

The valve is located on the left side* of the fireplace behind the surround.

The fan is located on the inside of the rear fireplace shell and can be accessed from the rear of the fireplace or through the front of the fireplace by removing the burner.

The exhaust and intake collars are located on top of the fireplace as marked.

*Left and right side references in this manual correspond with the sides identified in **Figure 6.2.01**.

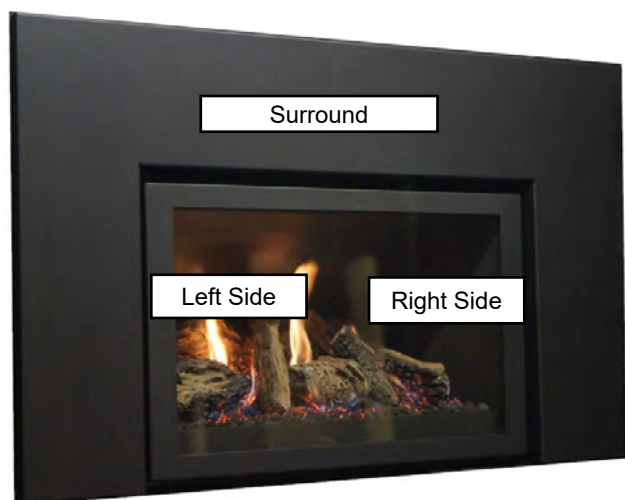

Figure 6.2.01:

TOP VIEW

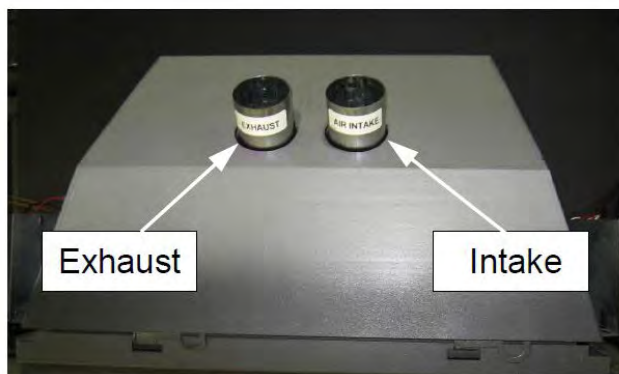

Figure 6.2.02:

Installation

CONTROLS IN

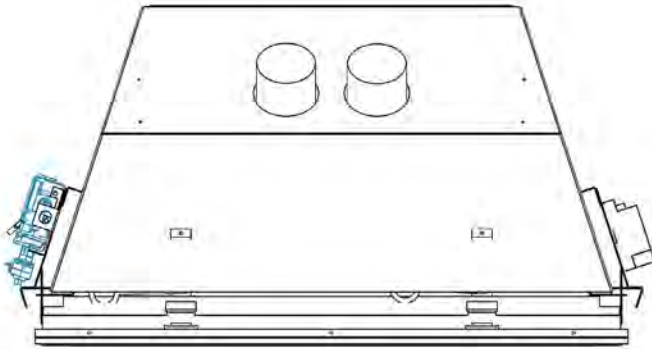

Figure 6.2.03:

CONTROLS OUT

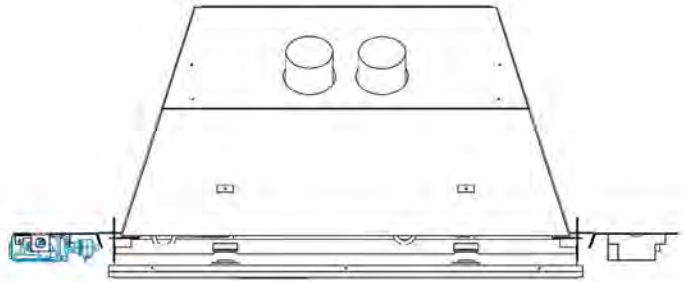

Figure 6.2.04:

6.3 Leveling the Appliance

The 27-DVIE22N-2 is equipped with front and rear leveling bolts. The fireplace has the ability to independently level left/right and front/back.

Leveling is done from the bottom of the unit

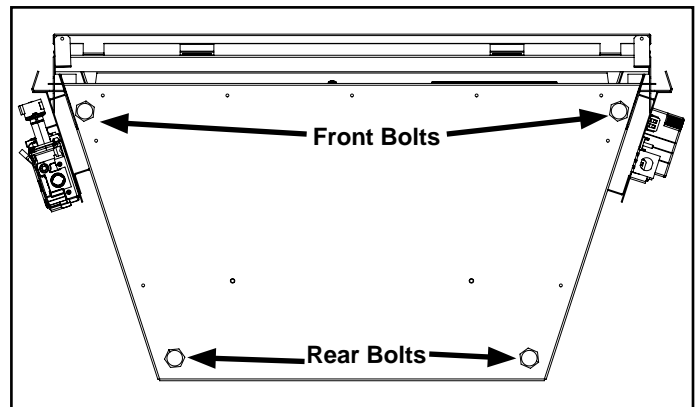

Figure 6.3.01:

7.0 Electrical Connections

The 27-DVIE22N-2 comes complete with an thermally controlled variable speed fan equipped with a solid state speed control.

Do not cut or remove the grounding prong from this plug.

NOTE: This appliance, when installed, must be electrically grounded in accordance with local codes or, in the absence of local codes, with the **National Electrical Code, ANSI / NFPA 70**, or the **Canadian Electrical code, CSA C22.1**.

CAUTION: Label all wires prior to disconnection when servicing.

8.0 Appliance Dimensions

8.1 Control Panel Locations

The control panels can be mounted in the following different ways. They are shipped in the "Controls In" configuration. They can be moved to the "Controls Out" configuration by removing the two mounting screw on each side and swinging the panels out and re-installing the screws. They can also be disconnected and placed remotely within the limits of the gas connections and electrical wiring making sure to place them away from any heat source over 150 degrees Fahrenheit or 65 degrees Celsius.

Fireplace dimensions are dependent on whether the fireplace is in "controls in" or "controls out" configuration.

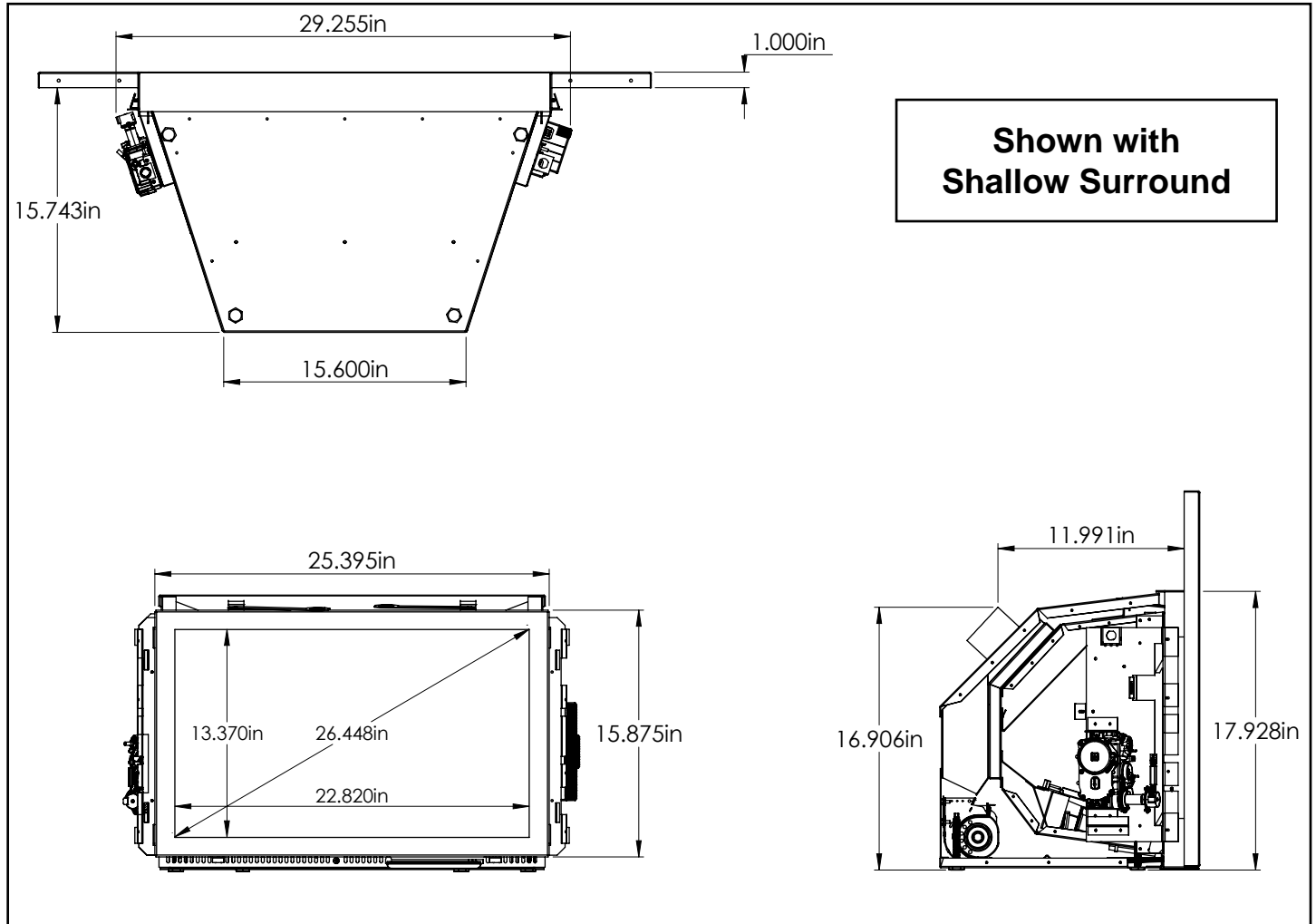

Figure 8.1.01:

Metric Equivalents										
	Inches	cm	Inches	cm	Inches	cm	Inches	cm	Inches	cm
FRONT	25.395	64.5	15.875	40.32	22.82	57.96	13.37	33.96	26.448	67.18
BOTTOM	29.255	74.31	15.743	39.99	15.6	39.62	1.0	2.54		
SIDE	17.928	45.54	16.906	42.94	11.991	30.46				

Installation

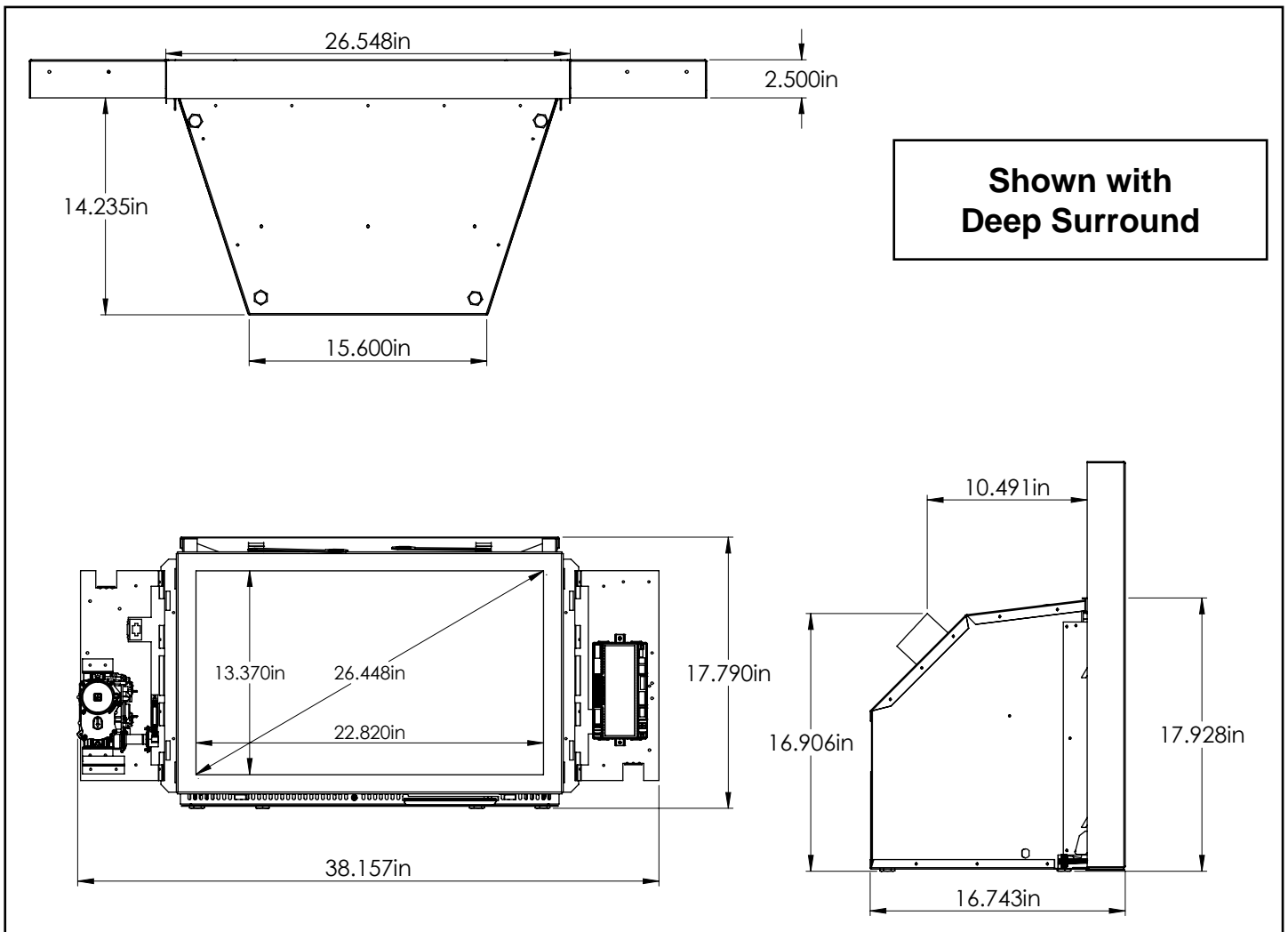

Figure 8.1.02:

Metric Equivalents								
	Inches	cm	Inches	cm	Inches	cm	Inches	cm
FRONT	38.157	96.92	17.79	45.19	13.37	33.96	26.448	67.18
BOTTOM	26.548	67.43	15.6	39.62	14.235	36.16	2.5	6.35
SIDE	17.928	45.54	16.906	42.94	16.906	42.94	10.491	26.65

9.0 Minimum Opening Dimensions

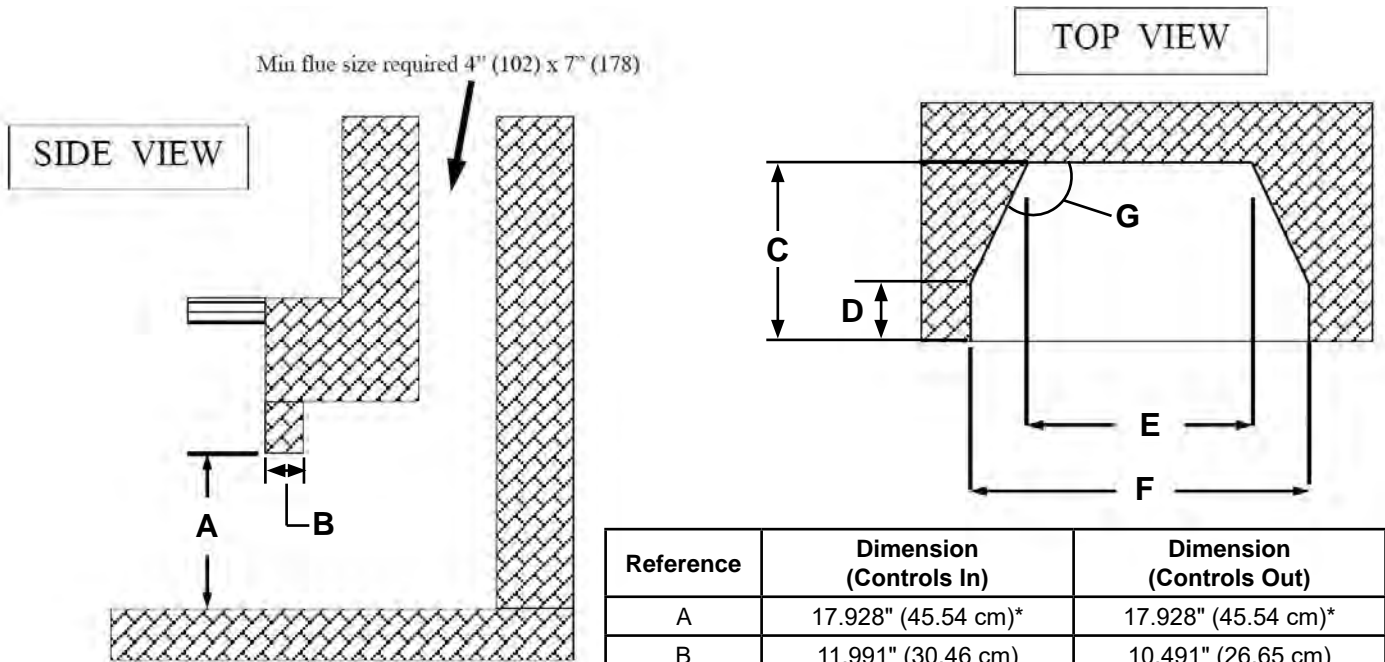

Figure 9.0.01:

Reference	Dimension (Controls In)	Dimension (Controls Out)
A	17.928" (45.54 cm)*	17.928" (45.54 cm)*
B	11.991" (30.46 cm)	10.491" (26.65 cm)
C	15.875" (40.32 cm)	14.375" (36.51 cm)
D	4.5" (11.43 cm)	0"
E	16" (40.64 cm)	15.75" (40.0 cm)
F	29.625" (75.25 cm)	27.125" (68.9 cm)
G	120.83°	111.6°

*It is possible to remove 0.125" from the height of the fireplace by removing the (4) leveling bolts from the bottom of the appliance (see Section 6.3).

WARNING: This fireplace has been designed to be installed into a Masonry or Factory Build Wood Burning Fireplaces **ONLY**. Never attempt to install the appliance into a combustible enclosure. If the information in these instructions are not followed exactly, a fire or explosion may result causing property damage, personal injury or loss of life.

The installer must mechanically attach the marking supplied with the gas fireplace insert to the inside of the firebox of the fireplace into which the gas fireplace insert is installed. See Figure 9.0.02.

WARNING: This fireplace has been converted for use with a gas fireplace insert only and cannot be used for burning wood or solid fuels, unless all original parts have been replaced, and the fireplace reapproved by the authority having jurisdiction.

AVERTISSEMENT: Ce foyer a ete converti pour utilisation avec un foyer au gaz encastrable et ne peut etre utiliser pour bruler du bois ou autres combustibles solides a moins que toutes les pieces d'origine ete remplacees et que le foyer ait ete approuve de nouveau par l'autorite competente.

303-0123

Figure 9.0.02:

Cutting of any sheet-metal parts of the fireplace, in which the gas fireplace insert is to be installed, is prohibited except as described in Section 9.1. The fireplace and fireplace chimney must be clean and in good working order and constructed of noncombustible materials. The chimney clean-outs must fit properly.

Installation

9.1 Factory Built Fireplaces

The following information applies to **Factory Built (metal) Wood-Burning Fireplace** installations:

Trim panels must not seal ventilation openings in the fireplace. Any parts that are removed must be saved and reinstalled if the insert is ever removed. If the factory-built fireplace has no gas access hole(s) provided, an access hole of 1 1/2" (38.1 mm) or less may be drilled through the lower sides or bottom of the firebox in a proper workmanship-like manner. This access hole must be plugged with noncombustible insulation after the gas supply line has been installed.

The damper (A) and grate with logset (B) must be removed or fully blocked open.

The smoke shelf (C), internal baffles (D), screen (E), masonry lining or refractory (G and I), and metal or glass doors (F) may be removed.

The fireplace must be permanently marked to indicate that it has been altered and is no longer suitable for burning any fuel unless the removed parts are reinstalled (See **Figure 9.0.02**). Cutting out of any metal parts is prohibited, except the metal floor (J) as specified.

The insulation (H), and any structured rigid frame member must not be removed or altered (side and top of door frame, side and top of the face of fireplace, metal sides, etc.).

The metal floor of the firebox may be removed only if the following is strictly adhered to.

The metal floor (J) may be removed to allow additional room for installation of the insert as long as it does not compromise the structural integrity of the existing fireplace (See **Figure 9.1.02**).

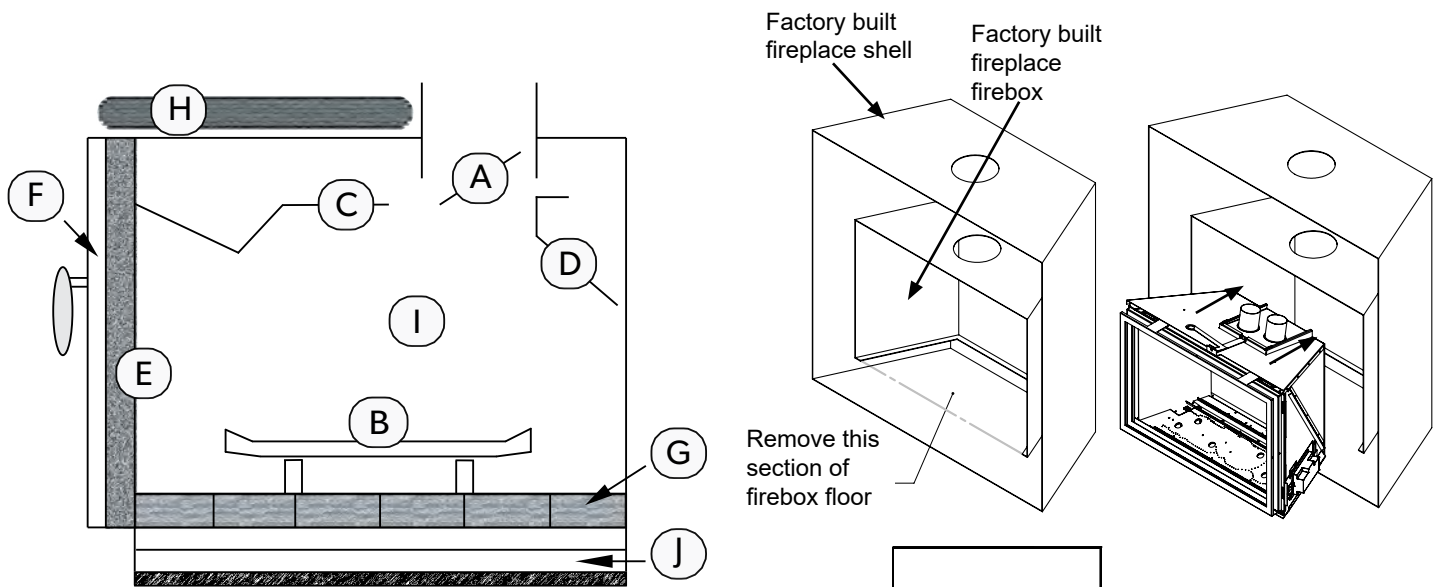

Figure 9.1.01: Side view of Factory Built (metal) Wood Burning Fireplace.

Figure 9.1.02: Removing the Metal Floor

Installation

9.2 Refacing a Masonry Fireplace

Using Steel Studs and Cement Board on Wood Fireplaces

Brick or rock facing may be removed and replaced with noncombustible material such as steel studs and cement board.

WARNING: Only facing material may be removed. All other masonry material must not be cut out, chipped away, or removed.

WARNING: Louvers or any air circulation around existing solid fuel fireplace must not be blocked or covered.

The area between the masonry and the cement board must be sealed so that no heat can enter the open space between the masonry of the wood fireplace and the refacing material. **The insert must be moved outward so that the face of the fireplace is flush with the finishing material.**

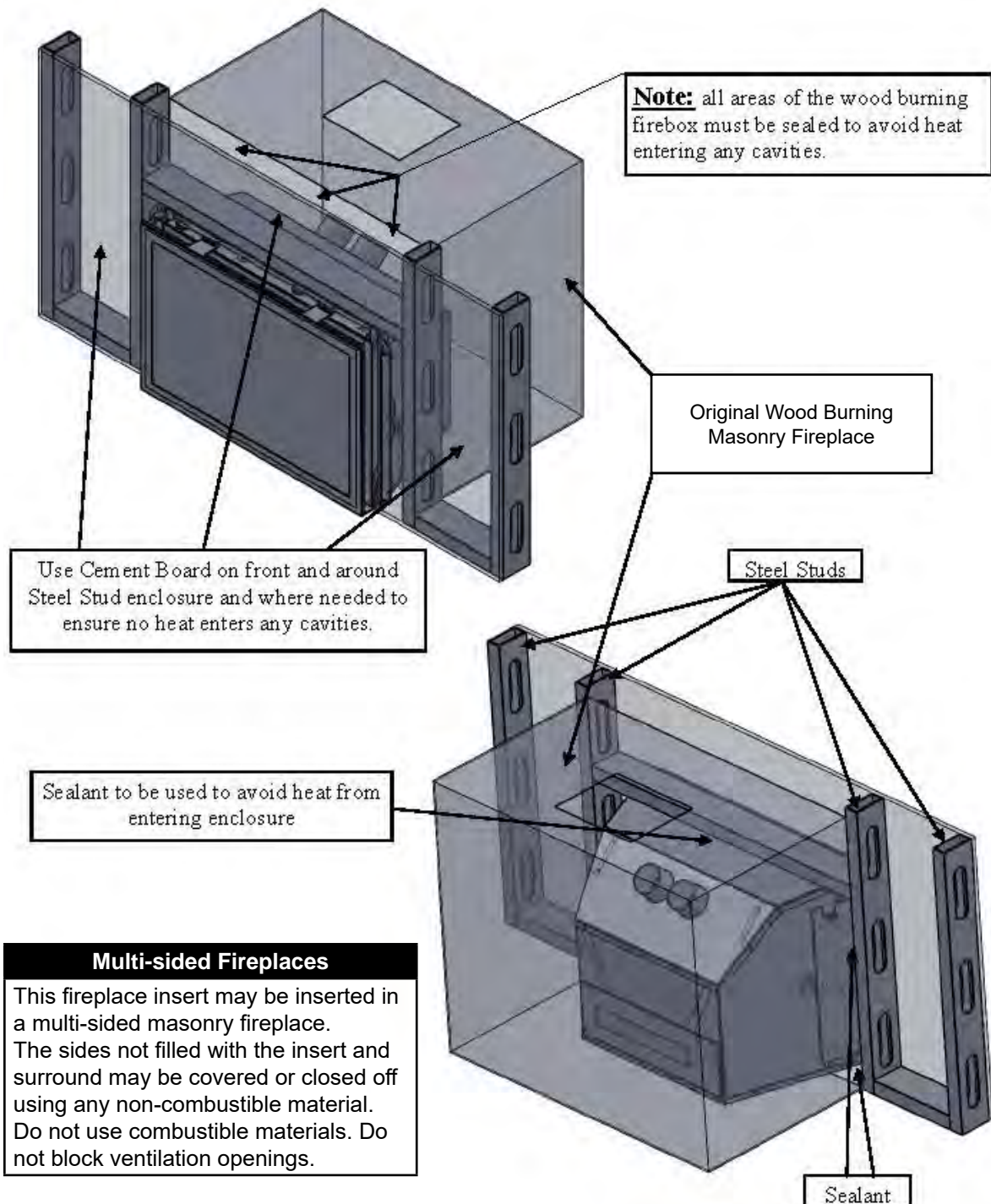

Figure 9.2.01:

Installation

10.0 Clearances to Combustibles

WARNING: Failure to position the parts in accordance with these diagrams or failure to use only parts specifically approved with this appliance may result in property damage or personal injury or loss of life.

CAUTION: This appliance is designed for use in any masonry or factory-built, wood-burning fireplace. It cannot be enclosed by combustible material and used as a factory built gas fireplace (zero clearance fireplace).

10.1 Mantel Clearances

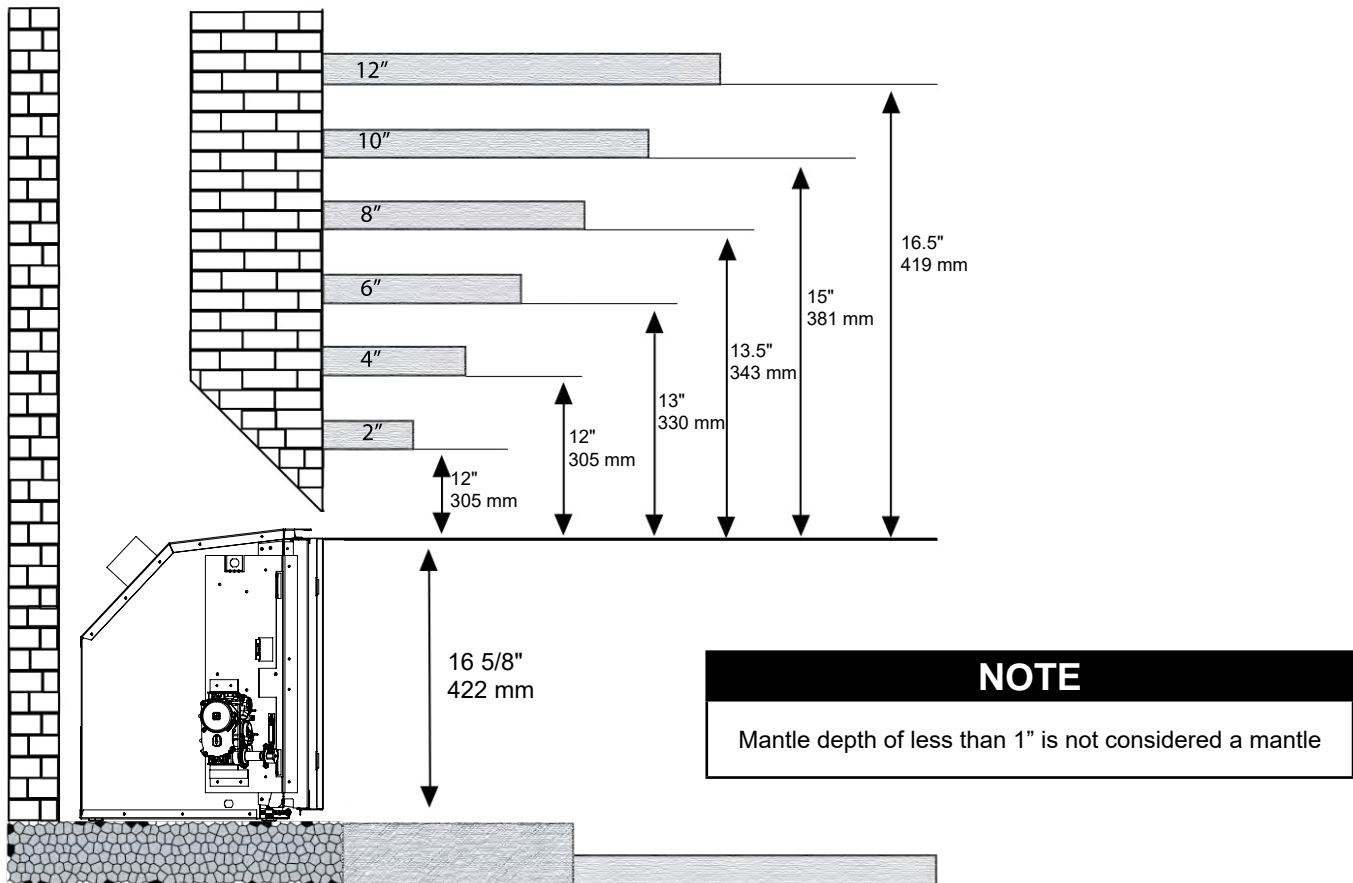

Figure 10.1.01

10.2 Sidewall Clearances

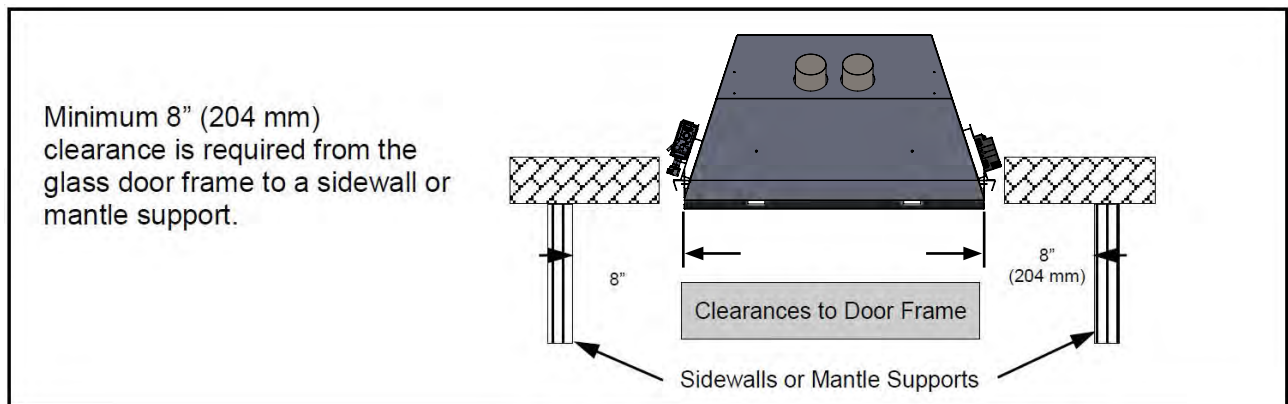

Figure 10.2.01

Installation

10.3 Hearth Clearances

WARNING

Failure to position the parts in accordance with these diagrams or failure to use only parts specifically approved with this appliance may result in property damage or personal injury.

Any hearth that extends outward in front of the insert must not have any combustible material closer than **3" (76.2 mm)** to the bottom of the gas fireplace insert regardless of whether a noncombustible material covers the combustible material. This includes any type of framing underneath a noncombustible material such as tile, marble, or stone. Any material farther than **3" (76.2 mm)** to the bottom or **9" (228.6 mm)** from the front of the door of the gas fireplace insert can be combustible.

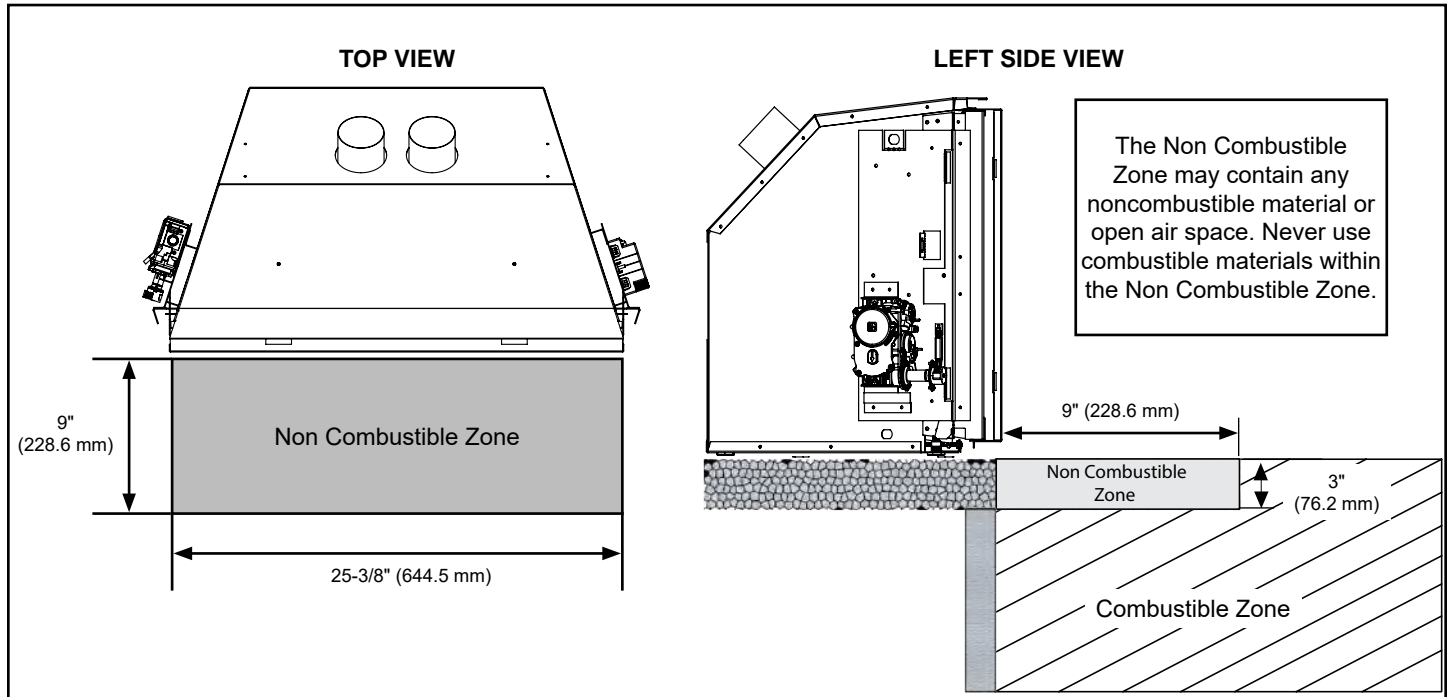

Figure 10.3.01

NOTE

All specified clearances must be maintained from the top surface of carpeting, tile, etc.

Installation

10.4 Heat Sensitive Flooring Materials

Ambiance fireplaces are heating products, designed to produce a large amount of radiant and convective heat. The clearances specified above are intended to be minimum clearance distances to combustible materials, however, flooring directly adjacent to the minimum hearth clearances may reach temperatures of up to 180°F (82°C) or higher depending on the installation.

Please check with your flooring manufacturer for temperature tolerances as some materials, such as vinyl, tend to be more sensitive to temperatures above average room temperature and may be damaged or warped if exposed to heat.

We recommend testing any flooring material to ensure that it can withstand temperatures generated by this fireplace. If the tolerances of the flooring material are not known or are not capable of withstanding the temperatures generated by this fireplace, install a heat pad constructed of material that is not sensitive to heat, or adjust clearances to heat sensitive materials as shown below.

Note: clearances shown are the width of the fireplace door. The dimensions shown are guidelines only and cannot account for all flooring material. The dimensions shown do not replace the hearth clearances for this product. Always maintain the clearances to combustible materials as shown on the previous page.

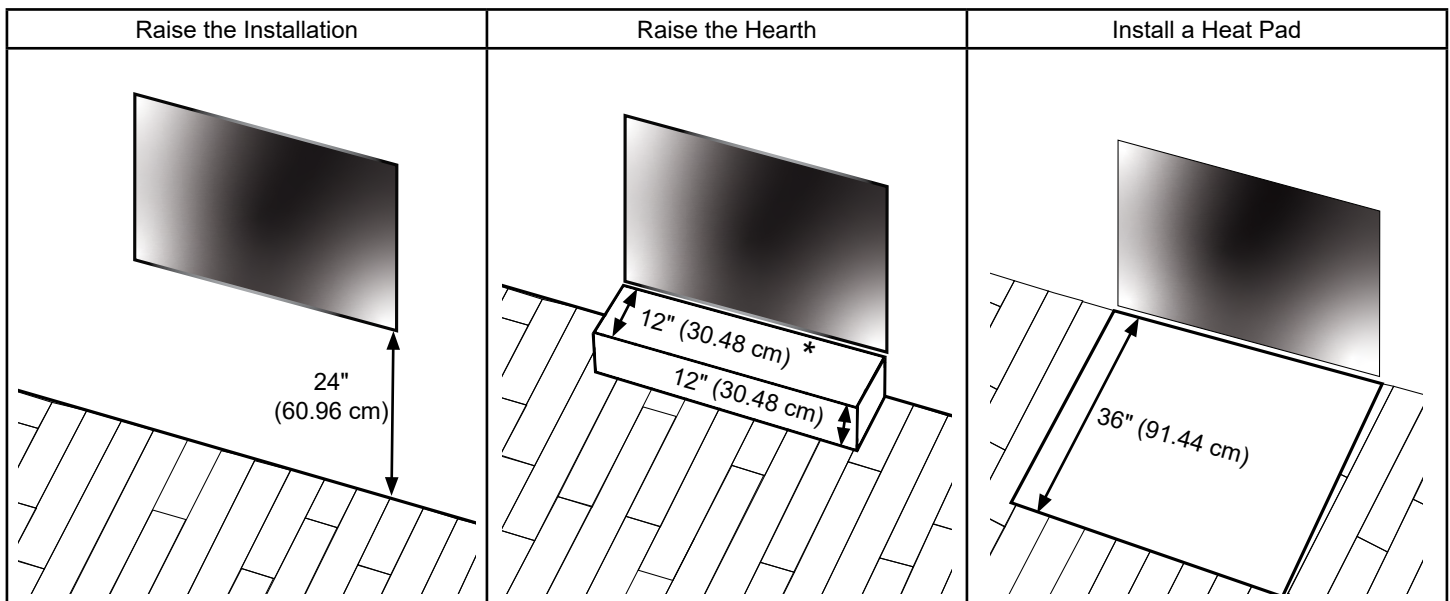

Figure 10.4.01

* Use whichever distance is greater when compared to the hearth clearances.

Installation

11.0 Gas Connections

Before connecting the appliance to the gas supply line, double check that the appliance you have purchased is designed for the gas type you are using. The gas type markings are located on the rating plate (See **Section 6.1**) and also on the appliance's gas valve.

Adequate clearance for proper installation and checking of the gas connections must be provided. **All gas connections must be checked for gas leaks.**

Have your gas supplier or a qualified gas fitter run a gas supply line into the solid fuel fireplace. The line must be properly sized and fitted according to the installation codes. Immediately upstream of the supply connection, the fitter shall provide an accessible manual shut-off valve. When connecting the supply line to the gas valve, the installer shall brace the gas valve to ensure that the gas valve is not moved from its bracket. If the valve is not braced when the supply line is connected, the valve may be moved and cause a "break" in the main burner supply line. Such damage is not covered by the manufacturer's warranty.

CAUTION: The appliance and its individual shut-off valve must be disconnected from the gas supply piping system during any pressure-testing of that system at test pressures in excess of 1/2 psig (3.5 kPa). The appliance must be isolated from the gas supply piping system by closing its individual manual shut-off valve during any pressure-testing of the gas supply piping system at test pressures equal to or less than 1/2 psig (3.5 kPa). Failure to do so will damage the appliance's gas valve. Such damage is not covered by the manufacturer's warranty.

Natural Gas Pressure Settings:

The inlet supply or line pressure must be a minimum of 5.0" W.C. (1.2 kPa) and a maximum of 14.0" W.C. (3.5 kPa). The orifice is a #43 DMS (2.25mm) drill size.

<u>ELEVATION</u>	<u>INPUT RATING</u>
0-4500 ft (0-1372 M)	22,400 BTU/hr (9.6 kW)
4500 ft (1372 M) and above.	22,400 BTU/hr (9.6 kW) less 4% per 1000 ft. (305 M)

Please contact your local distributor for the appropriate orifice size you require.

Propane Pressure Settings:

The inlet supply or line pressure must be a minimum of 11.0" W.C. (2.8 kPa) and a maximum of 14.0" W.C. (3.5 kPa). The orifice is a #54 DMS (1.36 mm) drill size.

<u>ELEVATION</u>	<u>INPUT RATING</u>
0-4500 ft. (0-1372 M)	21,000 BTU/hr (9.02 kW)
4500 ft. (1372 M) and above.	21,000 BTU/hr (9.02 kW) less 4% per 1000 ft. (305 M)

Please contact your local distributor for the appropriate orifice size you require.

To do this, reduce the background flow rate, time the meter.

11.1 Clocking Procedure

IMPORTANT: THE INPUT RATING SHOULD ALWAYS BE CHECKED WHEN FIRST FIRING THIS APPLIANCE.

Before you begin, shut off all other gas appliances including any standing pilots. Light the fireplace and wait 15 minutes. Clock the time to burn 1ft³ of gas on the meter. Check with your gas supplier for the gas BTU content at your elevation. Input is the rate of flow multiplied by the heating value of the gas (cubic feet/hour x BTU per cubic feet). Note: This assumes a dry gas meter at 1/2 psi. If using a 2 psi dry gas meter the unit will rate lower as the calculation has to correct for the higher pressure in the meter. If the unit is over-rated, contact your authorized Archgard dealer. The following calculation equation gives a rough estimation as it does not correct for temperature and pressure.

Rough Calculation Equation:

$$\frac{3600}{\text{time to burn 1ft}^3 \text{ gas in seconds}} \times \frac{\text{gas caloric value in BTU/ft}^3}{\text{Rating in BTU/hr}} = \text{Rating in BTU/hr}$$

Installation

12.0 Conversion Kit Instructions

IMPORTANT: This fireplace is Natural gas ready. If converting to LP gas, follow instructions below.

WARNING: This conversion kit shall be installed by a qualified service agency in accordance with the manufacturers instructions and all applicable codes and requirements of the authority having jurisdiction. If the information in these instructions is not followed exactly, a fire, explosion or productions of carbon monoxide may result, causing property damage, personal injury or loss of life. The qualified service agency is responsible for proper installation of this kit. The installation is not proper and complete until operation of the converted appliance is checked as specified in the instructions supplied with the kit. Refer to appliance owner's manual or product data plate for proper inlet and manifold pressure adjustments and orifice sizing.

IMPORTANT: For high altitude installations above 4500 ft (1372 meters), consult local gas distributor or the authority having jurisdiction for proper derating methods.

KIT NUMBERS: **27-CKELP** for LP gas and **27-CKENG** for Natural Gas

KIT INCLUDES:

- Gas conversion label (303-0128)
- Burner orifice (part number 301-0068-54, #54 DMS for LPG) (part number 301-0068-43, #43 DMS for NG)
- Instruction Sheet
- SIT 885 Valve conversion kit c/w instructions & gas type label

**WARNING: SHUT OFF GAS SUPPLY AND ELECTRICAL POWER TO FIREPLACE
SHUT OFF GAS SUPPLY BEFORE DISCONNECTING ELECTRICAL POWER**

12.1 Prepare the Fireplace

Remove the surround, barrier screen, glass frame assembly, logs, embers and brick panels or firebox liner (if applicable)*. Remove the burner*.

*See relevant sections in this manual.

Remove the burner orifice using a 1/2" wrench. Replace with the orifice supplied with the conversion kit. Use a small amount of pipe sealant on the threads of the orifice mount. Do not use too much as it can block the orifice.



Figure 12.1.01:

12.2 Pilot Conversion

Using a 7/16" wrench and loosen the pilot hood 1/4 turn. Slide the tab at the bottom of the orifice hood all the way so the red side (propane) with the hole in it is showing. Tighten the pilot hood back up so that it is lined up with the two probes on both sides of the pilot assembly.

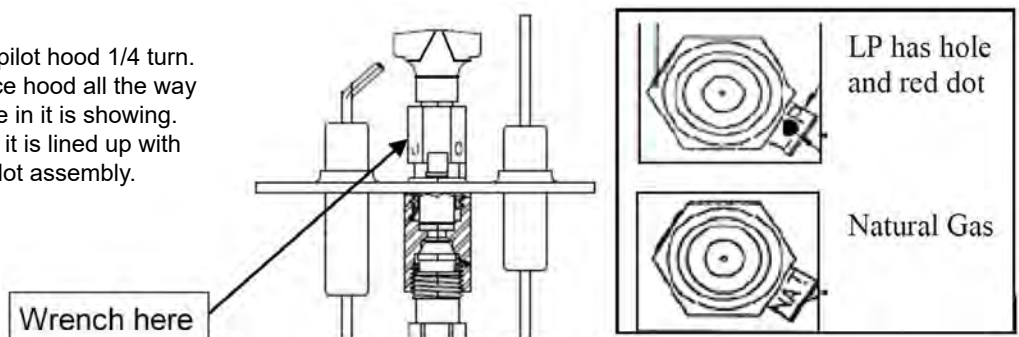

Figure 12.2.01:

12.3 Convert the Gas Valve

WARNING: Installation of this conversion kit must only be undertaken by a qualified and certified gas appliance installer.

Verify that the following items are present in the package:

- Pressure regulator assembly (E)
- Two (2) screws (F)
- Identification label (G)
- Installation instructions (this document)

1. Shut off the gas supply to the valve and shut down the electric supply.
2. See **Figure 12.3.01**. Using a Torx T20, or slotted screwdriver, remove and discard the two (2) pressure regulator mounting screws (A), pressure regulator tower (B), and the spring and diaphragm assembly (C), (if applicable).
3. Ensure the rubber gasket (D), which is prefitted as part of assembly (E), is properly positioned, see **Figure 12.3.02**, otherwise fit the gasket as shown **Figure 12.3.02**.
4. Install the new STEPPER MOTOR pressure regulator assembly, as shown in **Figure 12.3.03** and **Figure 12.3.04**. Use the supplied screws (F), M4 x 0.7 threaded, length of thread $L = (16 \text{ mm} + 0 - 0.5 \text{ mm})$, steel material, resistance class 8.8 (see **Figure 12.3.05**).
5. Manually thread the two conversion kit mounting screws into the valve body. Use a standard screwdriver or T20 Torx bit and tighten to the screws with a fixing torque of $25 \text{ lb-in} \pm 5\%$.
IN THE EVENT THAT THE THREADS OF THE VALVE ARE STRIPPED OR DAMAGED, REPLACE THE VALVE.
6. Install the enclosed identification label (G) to the valve body where it can be easily seen.
7. Make STEPPER MOTOR and valve electrical connections, apply gas to system and relight appliance according to manufacturers instructions.
8. With the main burner "ON", test the new pressure regulator assembly for leaks using a soap solution.
9. Relight the main burner and verify proper burner ignition and operation.

WARNING: Installation should be carried out in a clean environment.

WARNING: This modulating conversion kit must ONLY be applied as part of a conversion kit supplied by the APPLIANCE MANUFACTURER.

WARNING: Correct operation of the system cannot be guaranteed if the conversion kit or valve has been dropped or has sustained a strong impact.

INSTALLER NOTICE: These instructions must be left with appliance.

12.4 Complete the Conversion

- Reinstall the burner, brick liners or firebox liner, logs or glass media, embers, and door*
- Turn on the gas and electrical supplies
- Turn on the fireplace so the burner is on
- Check for leaks at **all** connections

Test inlet and outlet pressure (See **Section 20.3**). Visually check pilot flame. Flame should envelope top of the flame sensor and extend forward onto the burner. To adjust pilot turn the pilot adjustment screw on the control valve clockwise to decrease or counter clockwise to increase pilot flame. Clock the rating as shown in **Section 11.1**. Adjust the primary air according to specifications in this manual or as found on the rating plate.

- Turn fireplace off
- Affix gas type label to the rating plate label
(See **Section 6.1** for rating plate location)
- Complete the conversion label and affix to valve assembly plate
- Reinstall the barrier screen and surround*

*See relevant sections in this manual.

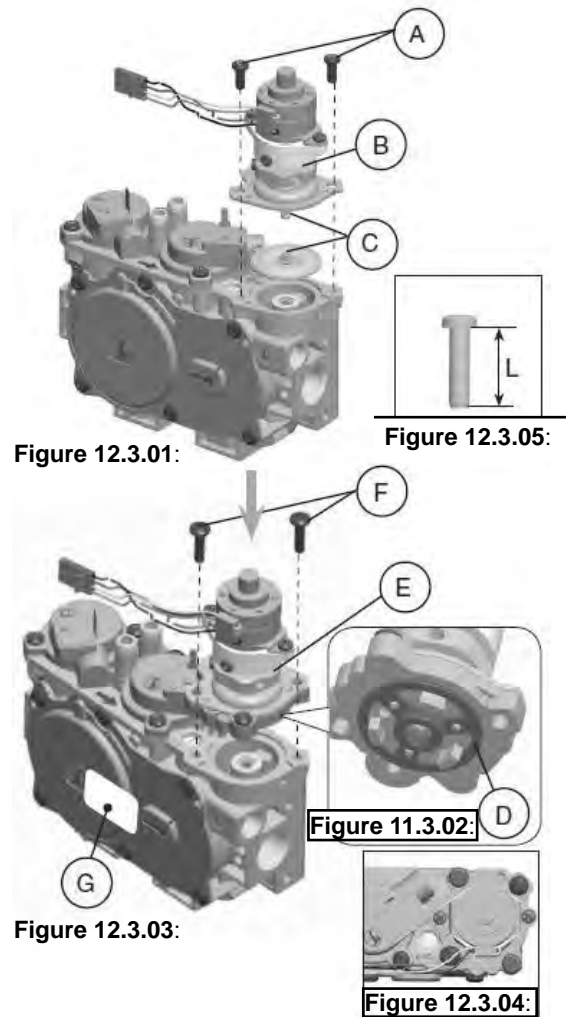

Installation

13.0 Venting Instructions

WARNING: Operation of this heater when not connected to a properly installed and maintained venting system can result in carbon monoxide (CO) poisoning and possible death. The appliance must not be connected to a chimney flue serving a separate solid fuel burning appliance.

CAUTION

Only approved 3" (7.6 cm) double wall aluminum or stainless flex liners and approved vent terminals are to be used for this appliance.

This appliance is designed for dual 3" (7.6 cm) double wall aluminum flex liner. The liner must run the entire length of the chimney from the appliance to the termination.

The flue length must be a minimum of 10' (3.05 M) and a maximum of 40' (12.2 M) from the top of the gas fireplace insert.

The exhaust vent restrictor provided with this appliance must only be used by installing it onto the front of the baffle when the vent height is over 18' (5.5 M) if required.

Masonry chimneys may take various contours which the flexible liner will accommodate, however, keep the flexible liner as straight as possible, avoiding unnecessary bending but at all times keep a minimum of 3" (7.6 cm) inside bend radius.

CAUTION

To ensure that the venting is not accidentally obstructed or punctured, the damper of the host fireplace must be permanently disabled by either complete removal of the damper, or by being fully blocked open, for the installation of a gas fireplace insert.

Sealing the Vent

Secure the flexible liner at the top of the fireplace and at the termination. **DO NOT** use silicone as this will void the flame sensor warranty. Use mil-pac or other non-silicone sealant and gear clamps included with this fireplace.

The Air Intake Flex Liner must form a tight connection to the inlet air collars of the termination cap and the appliance.

The Exhaust Flex Liner must form a tight connection to the exhaust collars of the termination cap and the appliance.

The Air intake and Exhaust connections are marked on the gas appliance. See Figure 13.0.01.

DO NOT REVERSE THESE CONNECTIONS

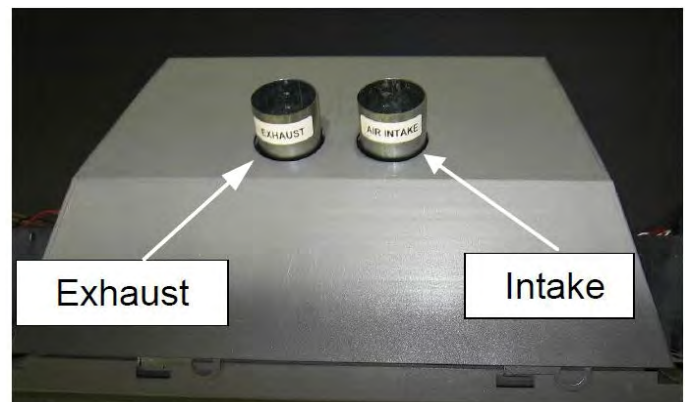

Figure 13.0.01: Intake & Exhaust as viewed from top of fireplace.

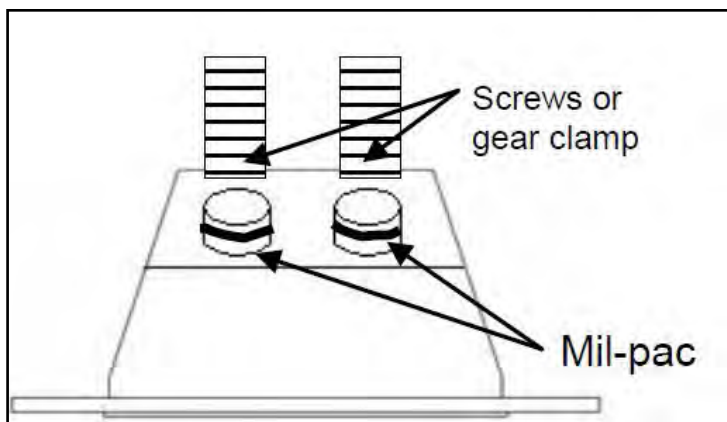

Figure 13.0.02:

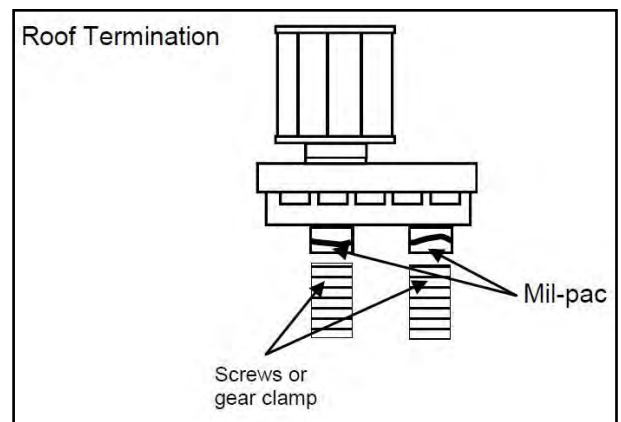

Figure 13.0.03:

DO NOT USE SILICONE TO SEAL VENT

13.1 Approved Terminations

The following Archgard venting components are available from your local Archgard dealer.

Archgard Venting Components	
Vent Component	Part Number
Vertical Termination	999-INS-TK
3" x 30' Aluminum Flex Liner	999-INS-FL330
3" x 50' Aluminum Flex Liner	999-INS-FL350
Approved venting components from third party manufacturers may be found on the following page.	

Installation

Third Party Venting Components					
	BDM	Selkirk	Duravent	ICC	Amerivent
3" Flex (10ft)	95270310	AFE10-03	N/A	N/A	3ALKE10
3" Flex (25ft)	95270325	AF3-25L	3DFA-25	N/A	1730250
3" Flex (30ft)	95270330	N/A	N/A	N/A	N/A
3" Flex (35ft)	95270335	AF3-35L	3DFA-35	TC-3AL35	1730350
3" Flex (50ft)	95270350	AF3-50L	N/A	TC-3AL50	3ALKE50
3" Flex Coupling	95090390	AF3-FC	3DFA-FC	TM-CFAA3	Comes with
4x6 5/8 Coaxial High Wind Cap	DVR6-VCH	4DT-VC	46DVA-VCH	TM-4SVT	N/A
4x6 5/8 Coaxial Low-Profile Cap	DVR6-LPC	4DT-VT	N/A	N/A	4DVC
3x3 Colinear to 4x6 5/8 Coaxial Adapter	DVF33-A6	4DT-CBT, 4DT-AAC	46DVA-GK or 46DVA-CLTA	TM-CTA	4DCAT33
High Wind Shield Round	DVR68-VWG	N/A	46DVA-VWG	TM-SVTS	N/A
High Wind Shield Rectangular	N/A	N/A	N/A	TM-CTS	N/A
Co-linear High Wind Vert Term Kit (with 35 ft. Flex) for Masonry Chimney	94203370HWS	1604645	46DVA-CL33	TM-ALK33	DVIK33 (Not High Wind)
Co-linear Rectangular Vent Term Kit (with 35 ft. Flex) for Masonry Chimney	N/A	N/A	N/A	TM-ALT33	N/A
Co-linear Direct Vent Factory Built Recline Kit High Wind Vert Term (with 35ft Flex)	N/A	N/A	46DVA-CL33KFB	TC-AL35, TM-IVT, TM-IVTP	N/A
3x3 Co-linear Round Vert Term	940033HWS	1604643	N/A	TM-IVT	DVCC33
3x3 Co-linear High Wind Vert Term Round Base	9400332RD	N/A	N/A	TM-IVT, TM-IVTP	N/A
3x3 Co-linear High Wind Vert Term Square Base	940033HWS	N/A	N/A	TM-IVT, TF-MFR, TF-MFC, TF-MF	N/A
Co-linear Masonry Flashing Rectangular Vert Term	N/A	N/A	N/A	TF-CTF, TF-CTFC	N/A
3x3 Co-linear Square Vert Term	940033, 9400330808SS	N/A	N/A	N/A	N/A
3x3 Co-linear Rectangular Vert Term	940034EC26SS	N/A	N/A	TM-CT3	N/A
Co-linear Masonry Flashing Rectangular Vert Term	N/A	N/A	N/A	TF-CTF, TF-CTFC	N/A
Prefab Chimney Flashing	N/A	N/A	N/A	TM-IVTP	N/A
3" Appliance Co-linear Flex Connector	N/A	4DT-CFC	46DVA-ADF	N/A	N/A
3x3 Co-linear Square Double Cap	940033DBL	N/A	N/A	N/A	N/A

ATTENTION

NO OTHER VENTING SYSTEM OR COMPONENTS MAY BE USED.

Part numbers shown are correct at the time of printing and should be confirmed with the manufacturer prior to purchase.

Follow manufacturer instructions for installation of termination.

Installation

13.2 Min/Max Vent Run

Instructions for installing venting and terminations (see list for approved venting and terminations).

Install the termination cap being sure to provide sufficient space (around and on top) so you do not impede the flow of air, both into and out of the cap. This cap is only to be used for non combustible installations. Do not recess into the top of the chimney.

1. Mark each end of one flex liner with "Air Intake".
2. Mark each end of the second flex liner with "Exhaust".
3. Pull the liner through the chimney.
4. Install the flashing.
5. Seal and attach the flex liner marked "Air Intake" to the vent terminal pipe marked "Air Intake" as per terminal manufacturers instruction. **DO NOT USE SILICONE.**
6. Seal and attach the flex liner marked "Exhaust" to the vent terminal pipe marked "Exhaust" as per terminal manufacturers instruction. **DO NOT USE SILICONE.**
7. Seal and attach the end of the flex liner marked "Air Intake" to the collar marked "Air Intake" on the appliance with the collar clamp provided with the unit. **DO NOT USE SILICONE.**
8. Seal and attach the end of the flex liner marked "Exhaust" to the collar marked "Exhaust" on the appliance with the collar clamp provided with the unit. **DO NOT USE SILICONE.**
9. Caulk all joints using a high temperature sealant such as milpac. **DO NOT USE SILICONE. Use of silicone sealants voids the warranty of the pilot assembly.**

NOTE: The flex liners must form a complete connection from the appliance flue collars to the vertical termination cap.

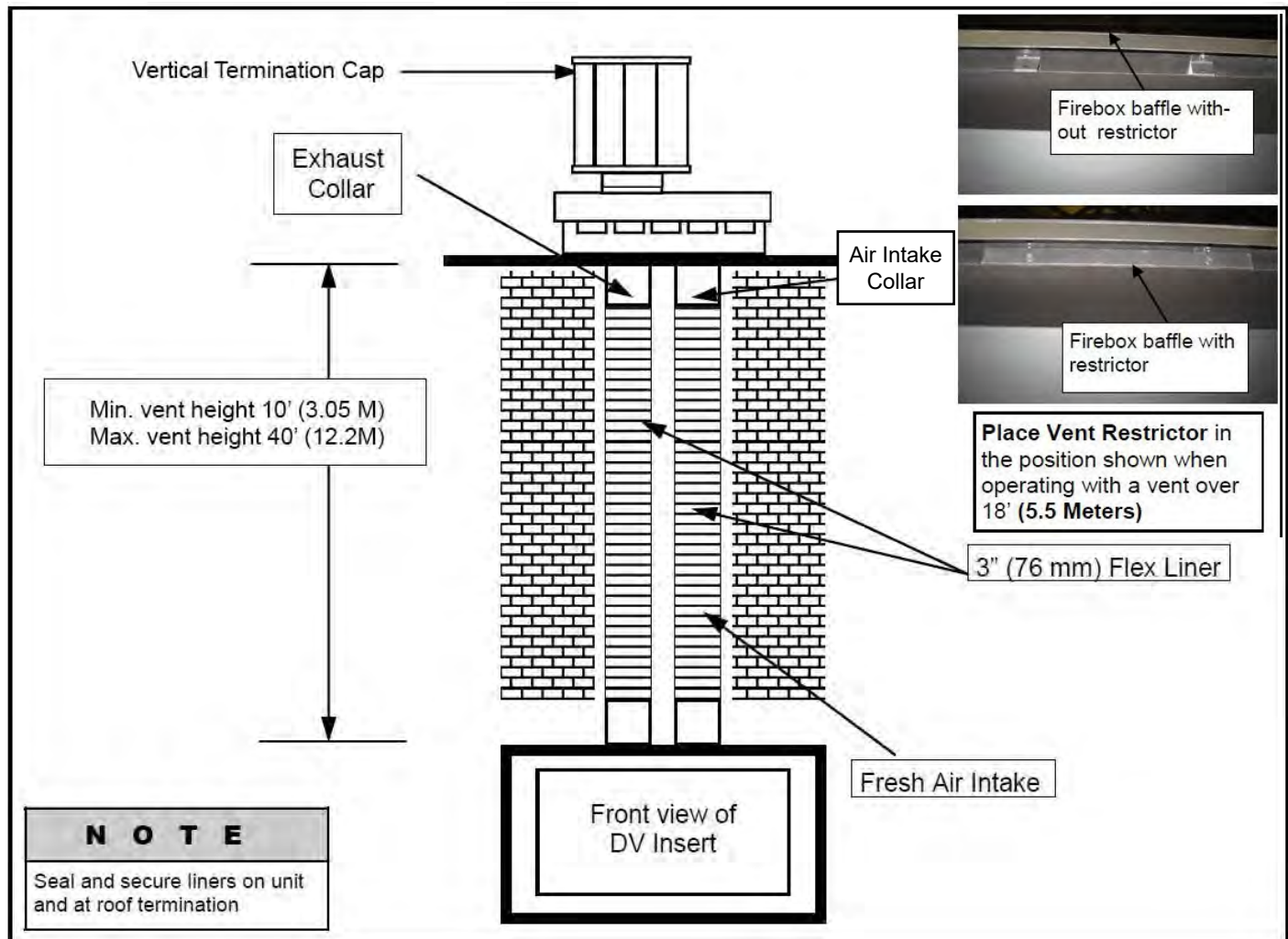

The minimum flue (chimney) size required to run the two 3" (76 mm) is 4" x 7" (100 mm x 178 mm).

Figure 13.2.01:

Installation

13.3 Using a Co-linear to Coaxial Adapter

(Partial Length)

The gas fireplace can be converted from co-linear to coaxial when it is desired to remove a section of the masonry or certified solid fuel burning fireplace chimney to below the roof line. The following image shows removal to the ceiling.

WARNING

This appliance must be installed by a qualified gas appliance installer. The installation must conform with the local codes or, in the absence of local codes, with the current National Fuel Gas Code ANSI Z223.1/ NFPA 54 in the US, or Installation Code CAN/ CGA-B149.1 in Canada. Electrical connections and grounding must conform with local code, or current National Electrical code ANSI/NFPA No. 70-1987 in the US, and in Canada the current Canadian Electrical Code CSA C22.1.

- A sealed flashing must be placed on top of the chimney where the co-linear to coaxial adapter is seated
- The total vent run must be a minimum of 10ft. from the top of the gas fireplace insert
- A 1" clearance must be maintained from the coaxial pipe to insulation and combustible material
- The termination must be 18" from the roof to the bottom of the termination

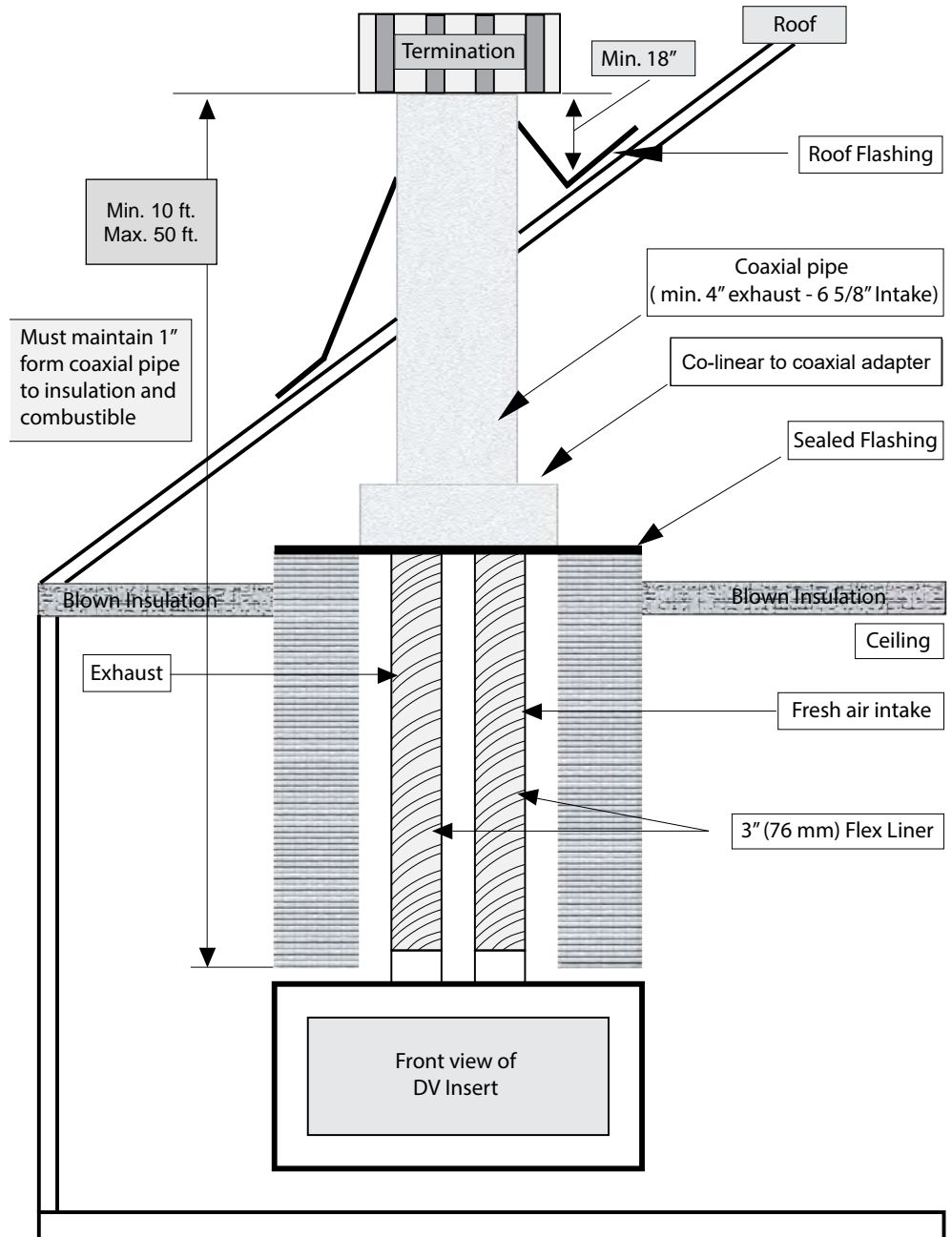

Figure 13.4.01:

General Information

(Full Length)

The gas fireplace can be converted from co-linear to coaxial when it is desired to remove a section of the masonry or certified solid fuel burning fireplace chimney to below the roof line. The following image shows removal to the top of the fireplace.

WARNING

This appliance must be installed by a qualified gas appliance installer. The installation must conform with the local codes or, in the absence of local codes, with the current National Fuel Gas Code ANSI Z223.1/ NFPA 54 in the US, or Installation Code CAN/ CGA-B149.1 in Canada. Electrical connections and grounding must conform with local code, or current National Electrical code ANSI/NFPA No. 70-1987 in the US, and in Canada the current Canadian Electrical Code CSA C22.1.

- A sealed flashing must be placed on top of the chimney where the co-linear to coaxial adapter is seated
- The total vent run must be a minimum of 10ft. from the top of the gas fireplace insert
- A 1" clearance must be maintained from the coaxial pipe to insulation and combustible material
- The termination must be 18" from the roof to the bottom of the termination
- Coaxial vent pipe may be a maximum of 50 ft. vertically

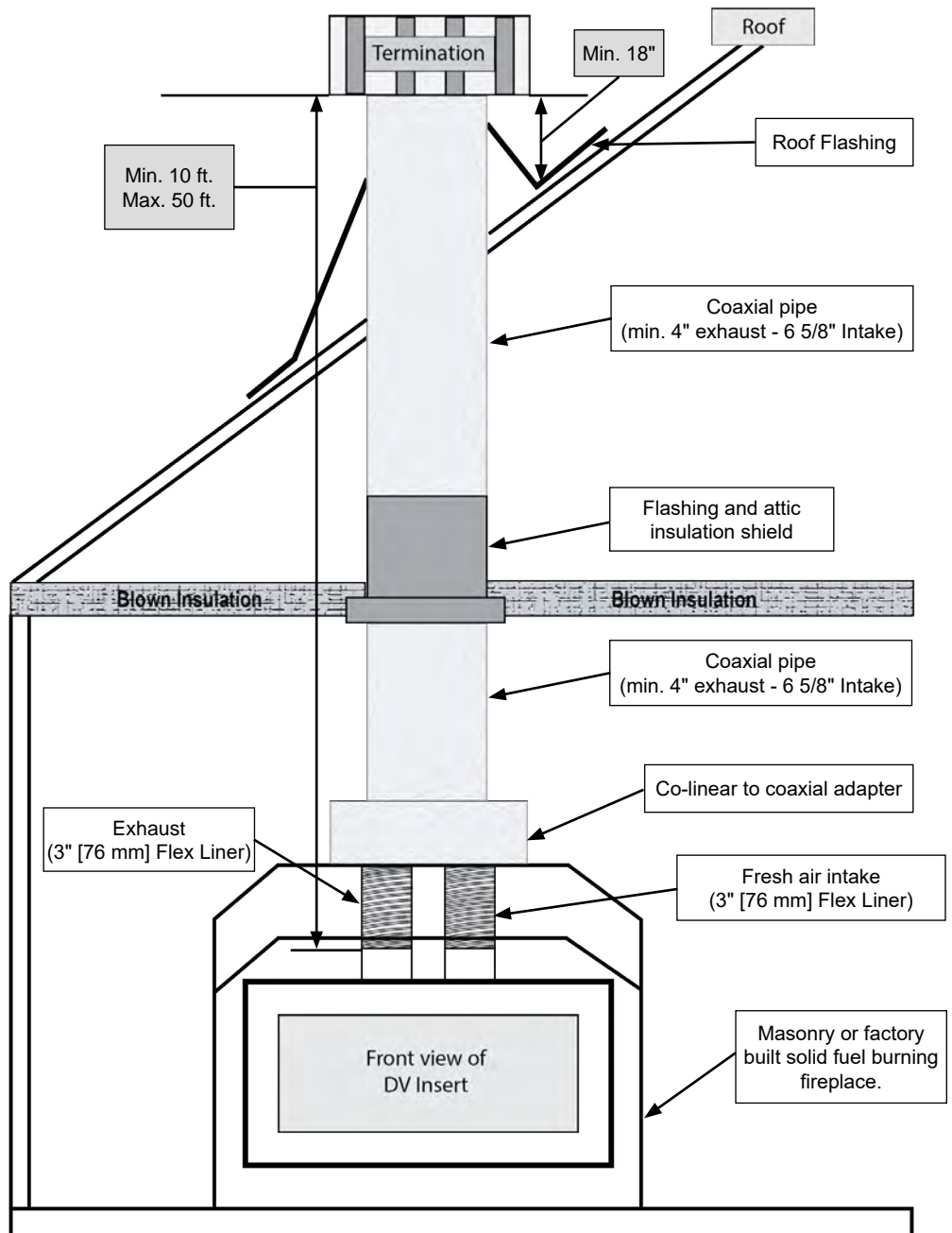

Figure 13.4.02:

14.0 Barrier Screen Installation

If barrier becomes damaged, the barrier shall be replaced with the manufacturer's barrier for this appliance (Part Number: **27-BS**).

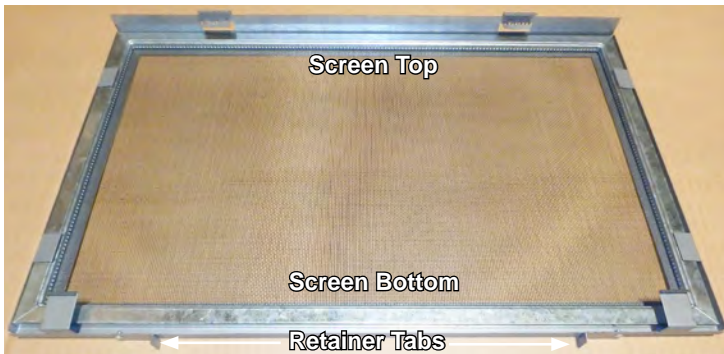

Figure 13.4.01:
Identify the top and bottom of the screen.
Ensure the screen retainer tabs are aligned along the bottom of the screen.

WARNING
**DOOR MUST BE INSTALLED PRIOR
TO SCREEN INSTALLATION TO AVOID
POSSIBLE DAMAGE OR INJURY.**



Figure 13.4.02:
Insert the hooks in the bottom of the screen between the door frame and glass. At the same time insert the hooks in the top of the screen into the holes at the top of the door frame.

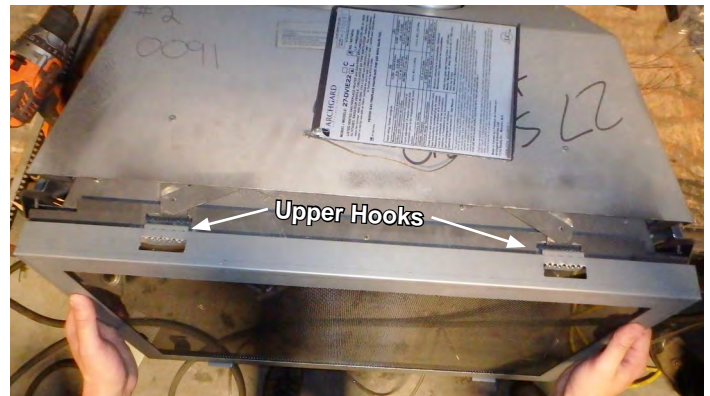

Figure 13.4.03:



Figure 13.4.04:
Rotate the retainer tabs under the door frame to secure the screen in place.

15.0 Glass Door Installation

WARNING: Do not operate appliance with the glass front cracked or broken. Replacement of the glass should be done by a licensed or qualified service person. Do not attempt to remove the glass door when the appliance is hot. Be sure there are no fingerprints left on the glass panels during install or when cleaning as high temperatures can bake these prints on permanently. Inspect the door gasket to ensure no damage has occurred when installing the door.

Removal:

1. Just above the door frame reach in and pull the two finger rings forward (See **Figure 15.0.01**).
2. Pull and lift the finger rings to detach from the door frame (See **Figure 15.0.02**).
3. Pull the door forward until the bottom catches release.
4. Lift door up and away.



Figure 15.0.01:

Installation:

1. To replace the door line up the two bottom catches with the notches on the fireplace. While pushing evenly on the bottom of the door lift up on the top of the door until it engages.
2. Push down on the top of the door to ensure the door is seated all the way down on the catches.
3. Pull the finger rings out and down to engage in the slots on the top of the door frame.
4. Push the finger rings back.

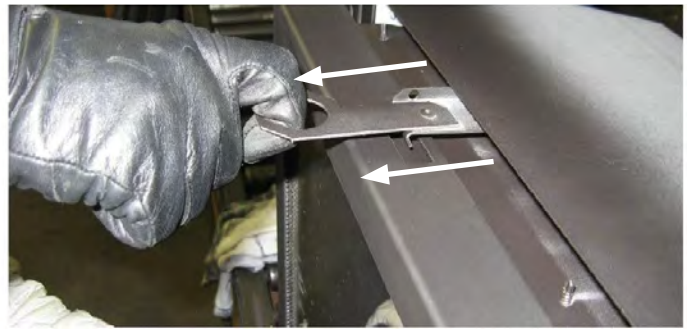

Figure 15.0.02:

15.1 If Your Glass Breaks

In the event your glass cracks or breaks, replace the original door assembly with Archgard replacement door assembly.

- Remove the barrier screen (See **Section 14.0**)
- Remove door as per the instructions above
- Replace with new door assembly and barrier screen

NOTE: the NEW door will emit some odor when the appliance is lit. The odor will dissipate after the gasket material within the door has cured. Be sure there are no fingerprints left on the glass panels as high temperatures can bake these prints on permanently.

Warning: Only doors certified with the appliance shall be used. Do not use substitute glazing materials.

16.0 Surround Installation

Surround options available depend on the control panel configuration (see **Section 6.2**). Shallow surround options are not available for a installations using the 'Controls Out' configuration.

Ensure the gas and electrical lines are properly connected to the appliance. Slide the unit into the fireplace and slide the excess venting material back into the chimney. Before the appliance is fully recessed into the fireplace, attach the surround onto the appliance.

Attach the surround to the appliance at the locations shown by aligning the tabs on the surround with the slots on the fireplace. Make sure the surround drops down and fully engages.

After placing the fireplace in the opening, slide the bottom filler plate under the lower edges of the surround (see **Figure 16.0.04**).

Care must be taken that Trim Panels or Surrounds shall not seal ventilation openings in the fireplace.

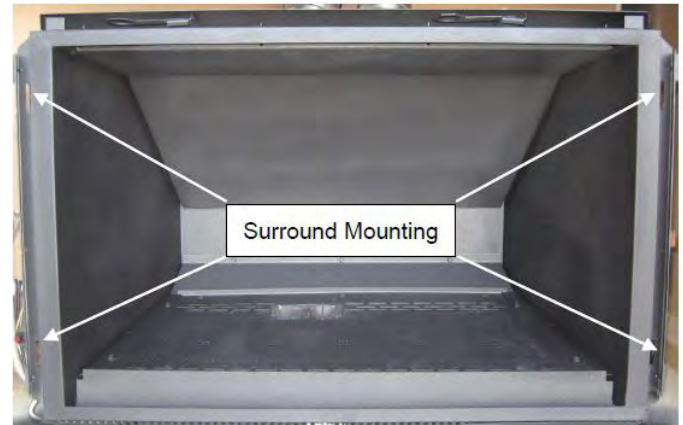

Figure 16.0.01:



Figure 16.0.02:



Shown with 27-SKSBS-2

Figure 16.0.03:

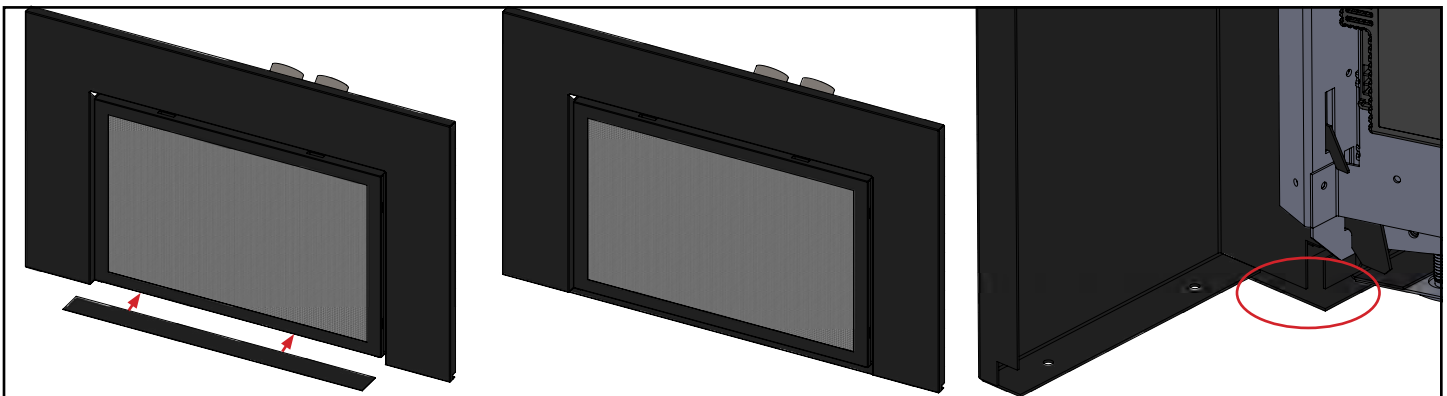

Figure 16.0.04:

Installation

16.1 Surround Dimensions

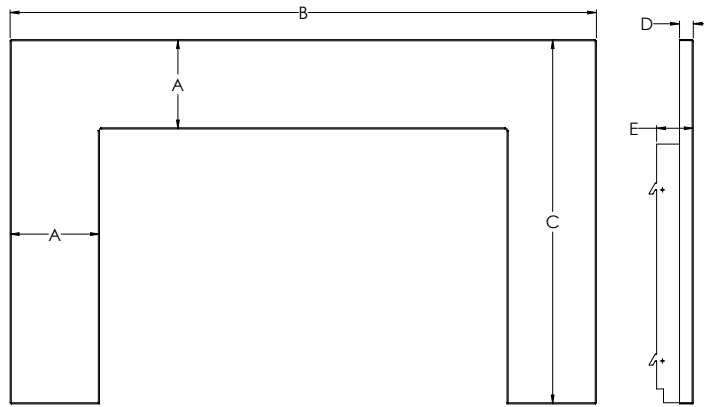

Figure 16.1.01:

Three Sided Surrounds				
	27-SKSBS-2 Small Shallow	27-SKSBD-2 Small Deep	27-SKLBS-2 Large Shallow	27-SKLBD-2 Large Deep
A	10.399" [26.41 cm]		10.399" [26.41 cm]	
B	39.452" [100.21 cm]		45" [114.3 cm]	
C	24.161" [61.37 cm]		28" [71.12 cm]	
D	1" [2.54 cm]	2.5" [6.35 cm]	1" [2.54 cm]	2.5" [6.35 cm]
E	2.849" [7.24 cm]			

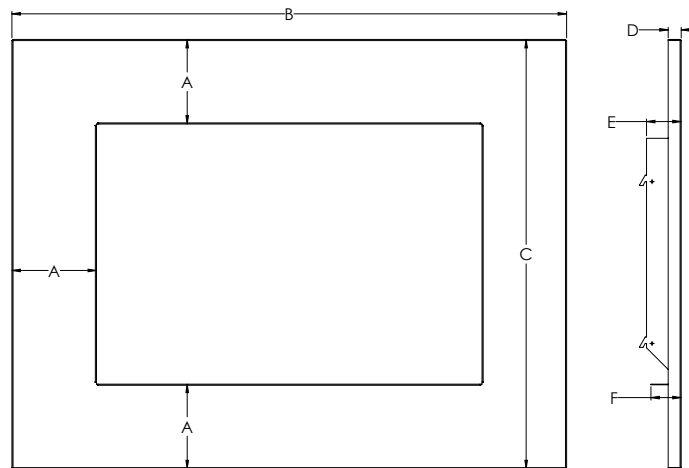

Figure 16.1.02:

Four Sided Surrounds				
	27-SK4SBS-2 Small Shallow	27-SK4SBD-2 Small Deep	27-SK4LBS-2 Large Shallow	27-SK4LBD-2 Large Deep
A	6.5" [16.51 cm]		10.399" [26.41 cm]	
B	39.452" [100.21 cm]		45" [114.3 cm]	
C	30.679" [77.92 cm]		38.357" [97.43 cm]	
D	1" [2.54 cm]	2.5" [6.35 cm]	1" [2.54 cm]	2.5" [6.35 cm]
E	2.849" [7.24 cm]			
F	2.276" [5.78 cm]			

16.2 Trimmable Surround Dimensions

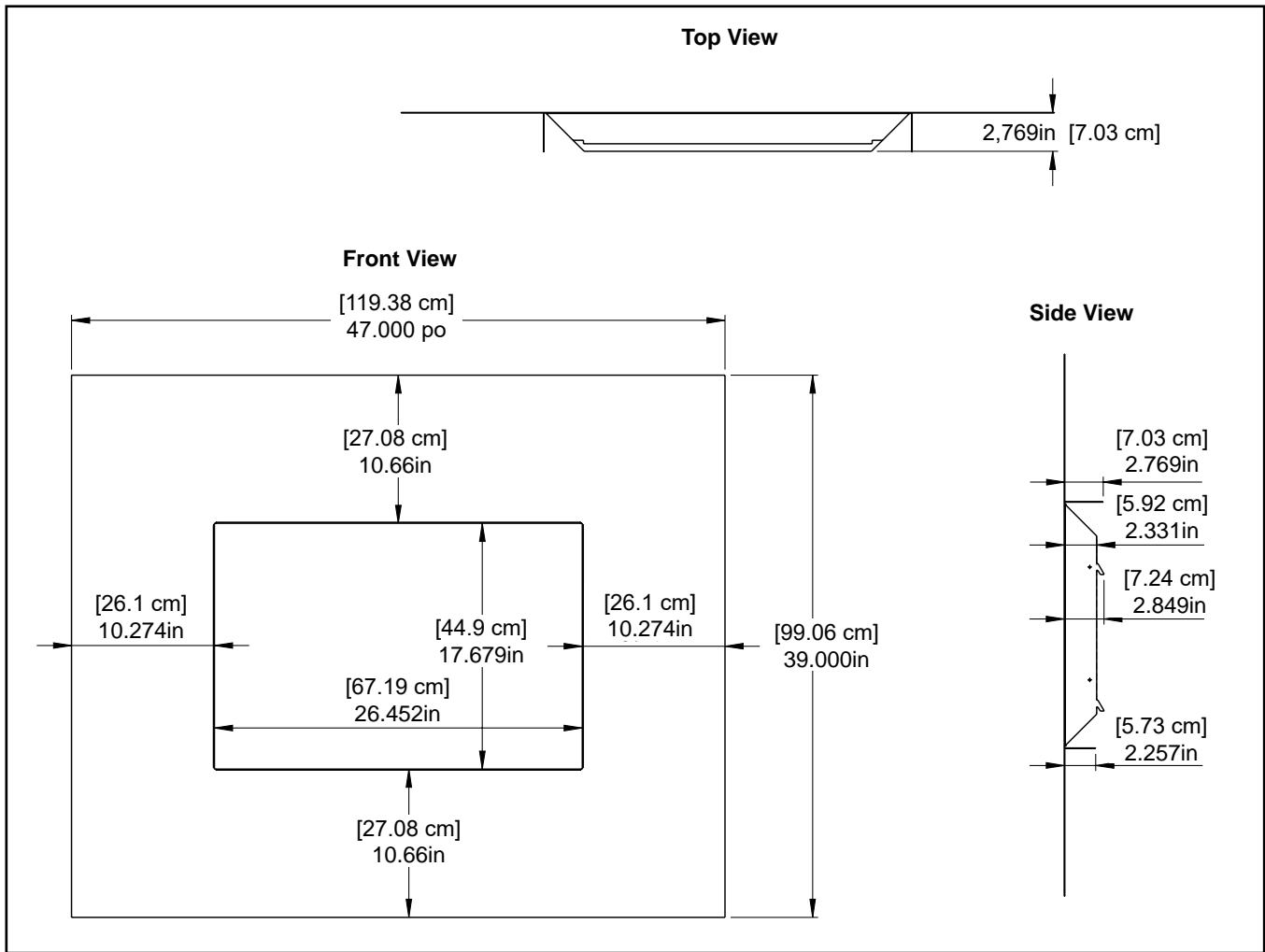

Figure 16.2.01:

Installation

16.3 Dimensions of Fronts

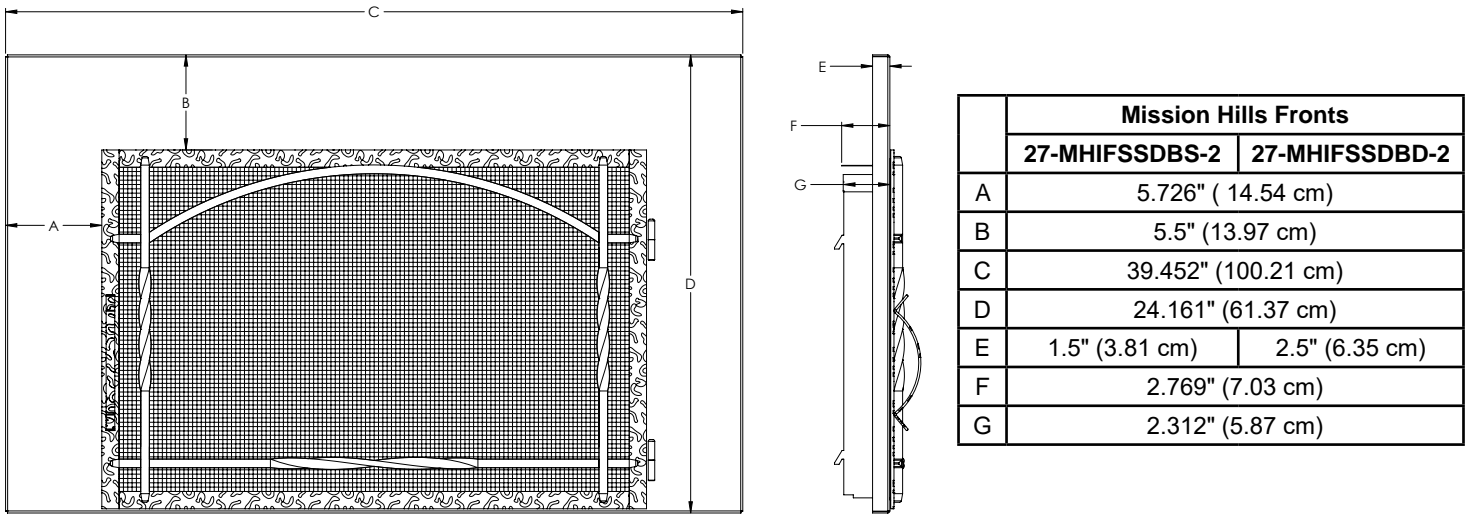

Figure 16.3.01: Mission Hills Front

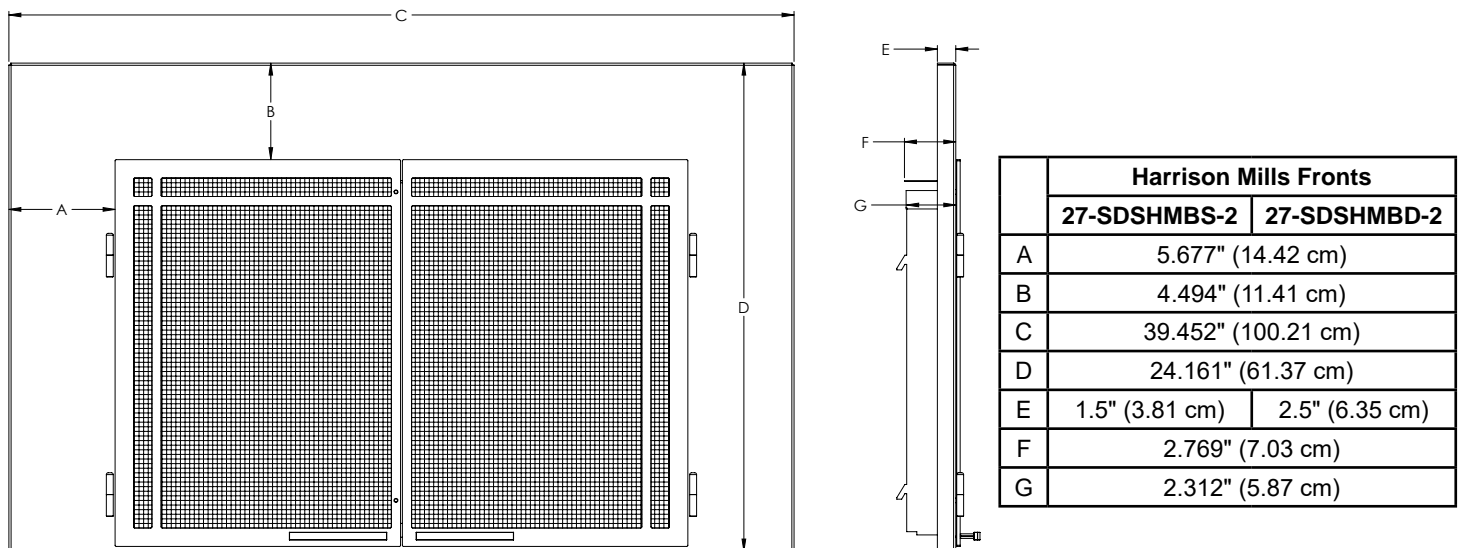

Figure 16.3.02: Harrison Mills Front

16.4 Decorative Trim Dimensions

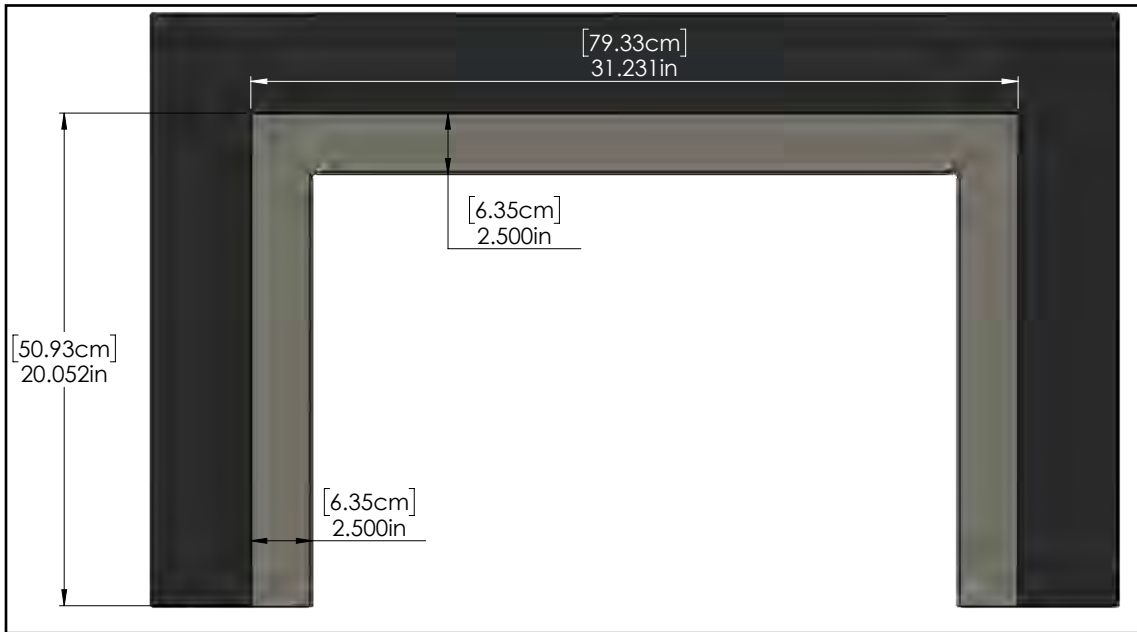

Figure 16.4.01:

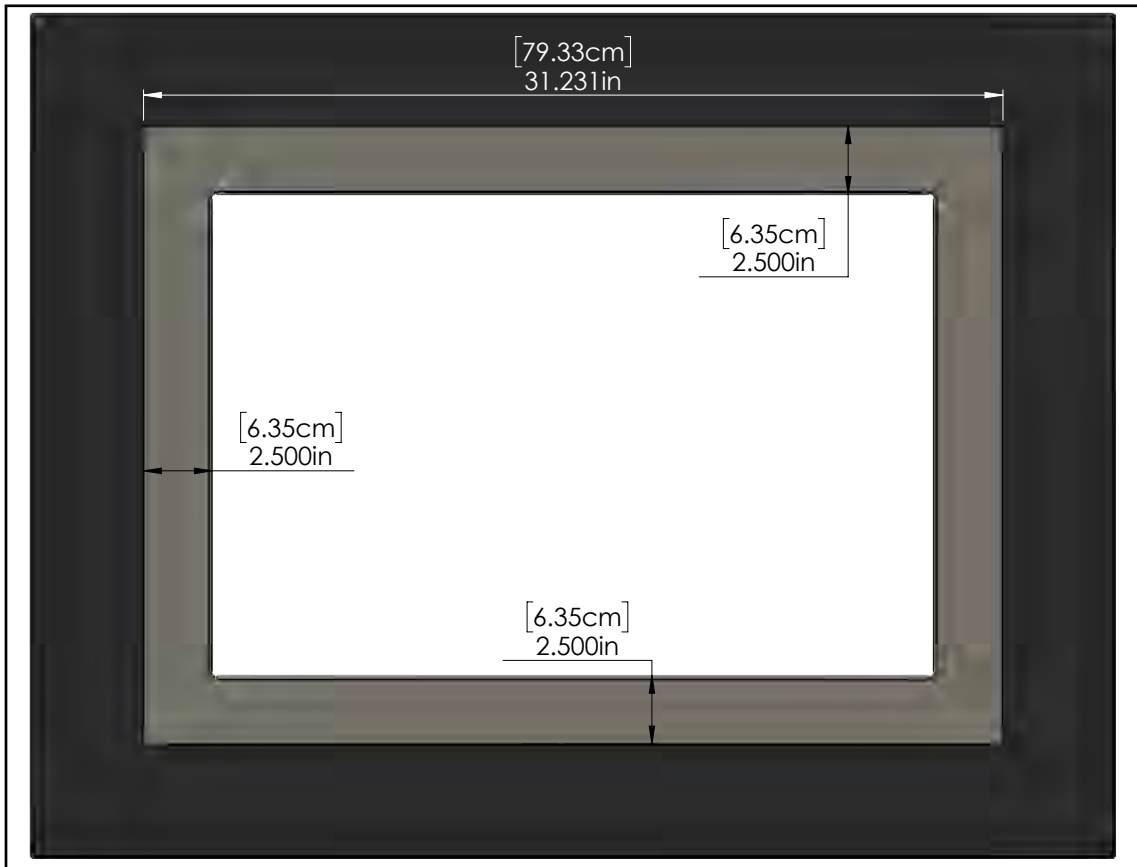

Figure 16.4.02:

16.5 Decorative Plinth Dimensions

Small Plinths

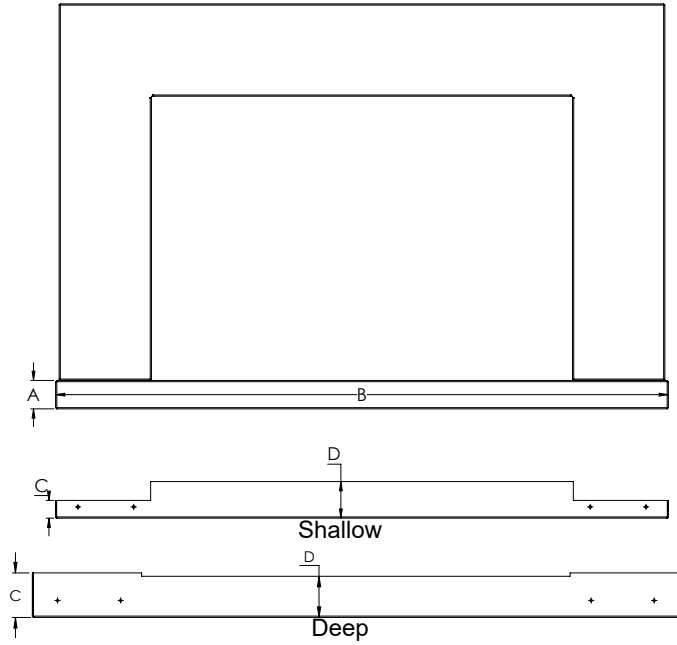

Figure 16.5.01:

		For use with 27-SKSBS or 27-SKSBD			
		A	B	C	D
Shallow	27-DPSS2	2" 5.08 cm	39.952" 101.48 cm	1.25" 3.18 cm	2.539" 6.45 cm
	27-DPSS4	4" 10.16 cm			
	27-DPSS6	6" 15.24 cm			
Deep	27-DPSD2	2" 5.08 cm	39.952" 101.48 cm	2.75" 6.99 cm	2.539" 6.45 cm
	27-DPSD4	4" 10.16 cm			
	27-DPSD6	6" 15.24 cm			

Large Plinths

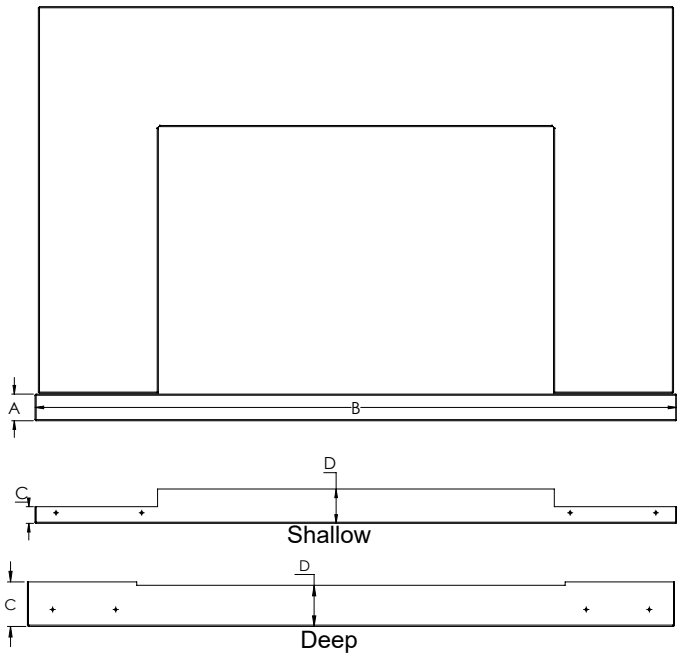

Figure 16.5.02:

		For use with 27-SKLBS or 27-SKLBD			
		A	B	C	D
Shallow	27-DPLS2	2" 5.08 cm	45.5" 115.57 cm	1.25" 3.18 cm	2.539" 6.45 cm
	27-DPLS4	4" 10.16 cm			
	27-DPLS6	6" 15.24 cm			
Deep	27-DPLD2	2" 5.08 cm	45.5" 115.57 cm	2.75" 6.99 cm	2.539" 6.45 cm
	27-DPLD4	4" 10.16 cm			
	27-DPLD6	6" 15.24 cm			

Installation

17.0 Firebox Liner Installation

17.1 Brick Panel Installation

The following steps highlight the procedure for installing brick panel firebox liners. Handle the panels with care as they are delicate. Inspect the panels to ensure that no damage has occurred inside the package. Please report any damage immediately to your Authorized Archgard Dealer.

Before you begin:

- **Ensure the gas supply is turned OFF and disconnect the power supply**
- Remove barrier screen (see **Section 14.0**)
- Remove Glass Door (see **Section 15.0**)
- Remove log set if installed (see **Section 18.1**)

The kit consists of the panels listed below and (2) brick clips.

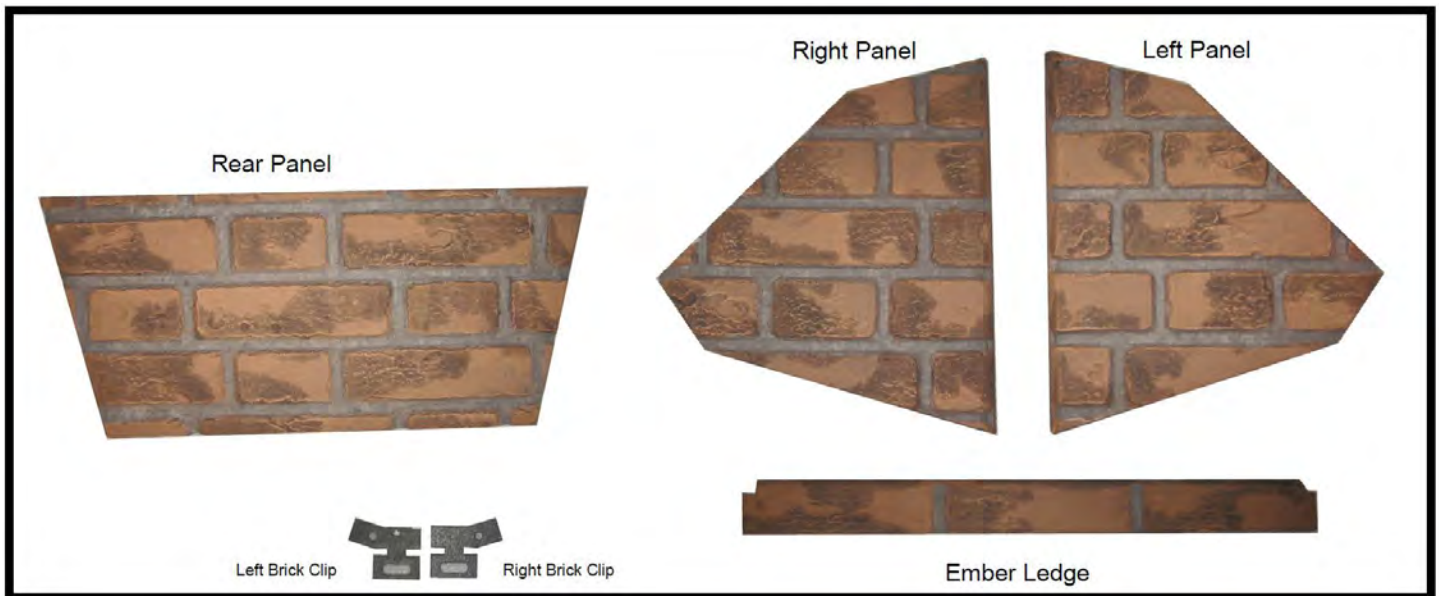

Figure 17.1.01:

Step 1: Insert the EMBER LEDGE panel into the space in front of the burner and gently push down to set in place. Be careful not to exert excess force or you may damage the panel.

Step 2: Starting with the LEFT or RIGHT SIDE PANEL, place the panel in the appropriate side. Using the brick clip, secure the panel. The clips are shipped flat and will need to be bent as shown in **Figure 17.1.04**.



Figure 17.1.02:

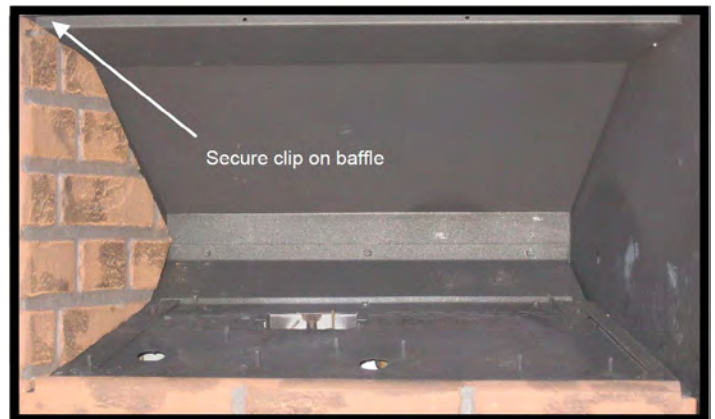

Figure 17.1.03:

Installation

NOTE: the tabs will bend with hand pressure, however, using pliers will give a sharper bend.

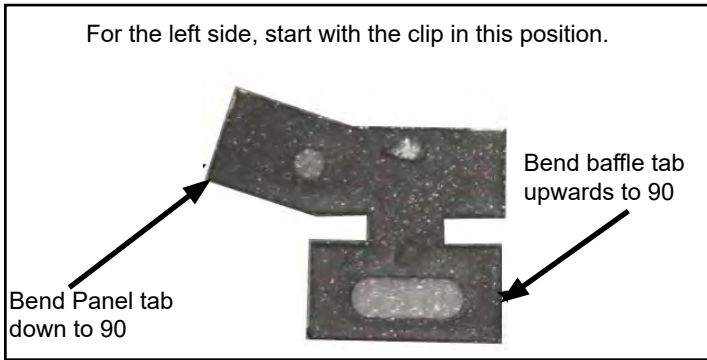

Figure 17.1.04:

Step 4: Slide the REAR PANEL in behind the side panel that was installed in Step 2.



Figure 17.1.05:

Step 5: Place the last SIDE PANEL in the appropriate side. Using the brick clip, secure the panel. The clips are shipped flat and will need to be bent as shown below.

NOTE: the tabs will bend with hand pressure, however, using pliers will give a sharper bend.



Figure 17.1.06:

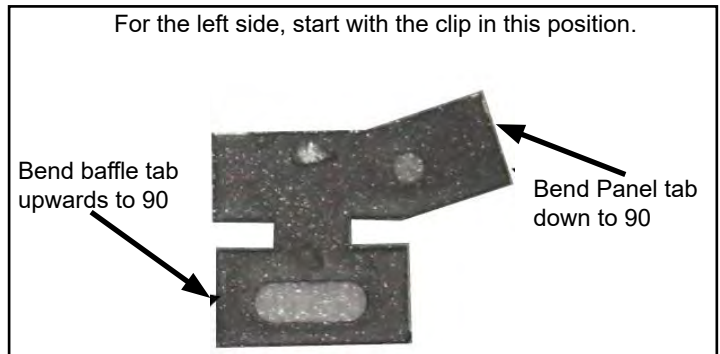

Figure 17.1.07:



Figure 17.1.08:

18.0 Media Installation

WARNING

Failure to position the parts in accordance with these diagrams or failure to use only parts specifically approved with this appliance may result in property damage or personal injury.

18.1 Log Set

The Archgard pan burner bed and fiber logs are designed to give a realistic fire package, and created to look the same as the day they were originally installed. Care must be given when first installing the logs, and if removed for servicing, as they can be damaged or broken if not handled properly.

After opening the log set package, inspect the logs to ensure that no damage has occurred inside the package. Please report any damage immediately to your Authorized Archgard Dealer.

Gas and vent connection must be made before installing the embers and logs on the pan burner.

CAUTION: DO NOT block pilot opening with embers or glass media material.

NOTE: Improper placement of logs and embers may cause soot accumulation on the internal parts and glass. This is not covered under warranty. Do not use broken or damaged logs.

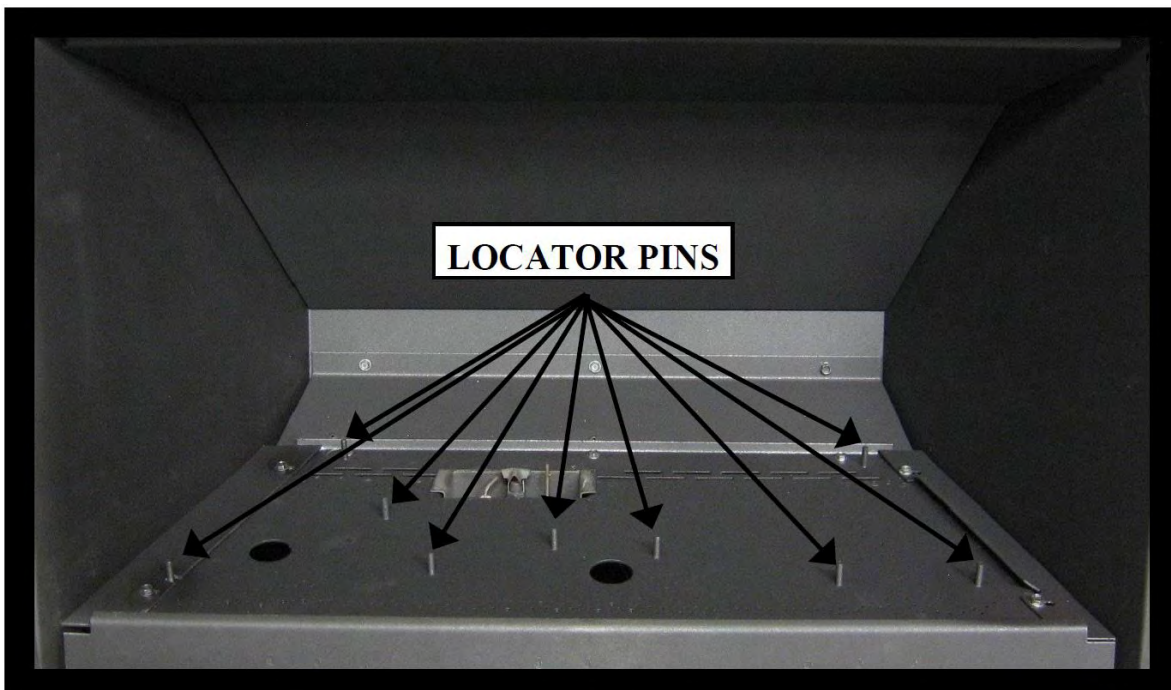

Figure 18.1.01:

Installation

Log #1: Locate Log 1 and align the holes in the bottom line up with the two locator pins. Push down firmly onto locator pins.

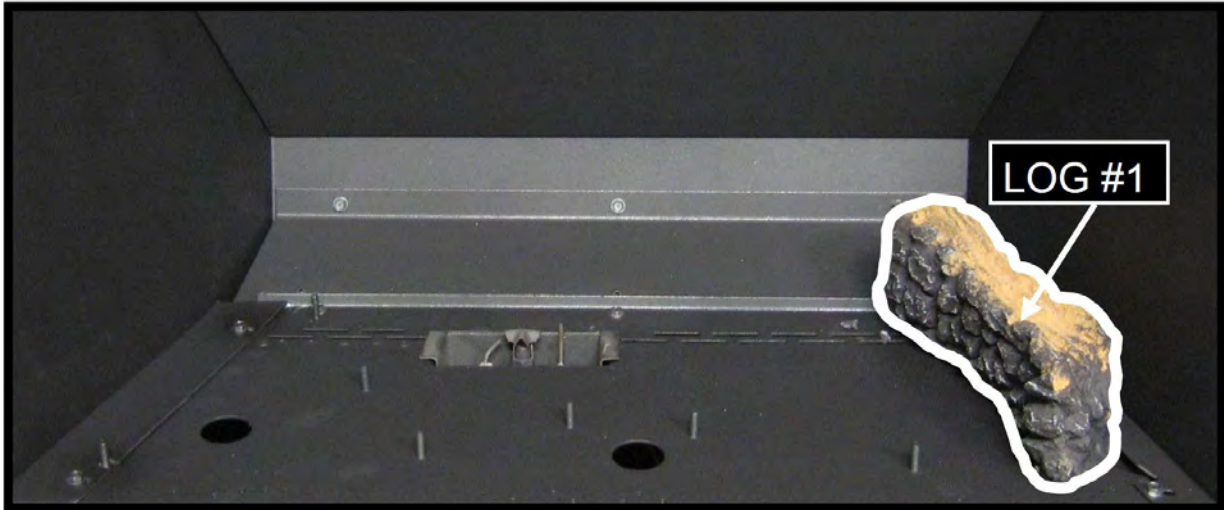

Figure 18.1.02:

Log #2: Locate log #2 using the locator pin on the burner for the left side. Sit the right side of the log into the notch of log #1 (as shown in inset).



Figure 18.1.03:

Log #3: Locate Log 3 and align the two holes in the log with the two locator pins on the left of the burner. Push down onto locator pins as shown.

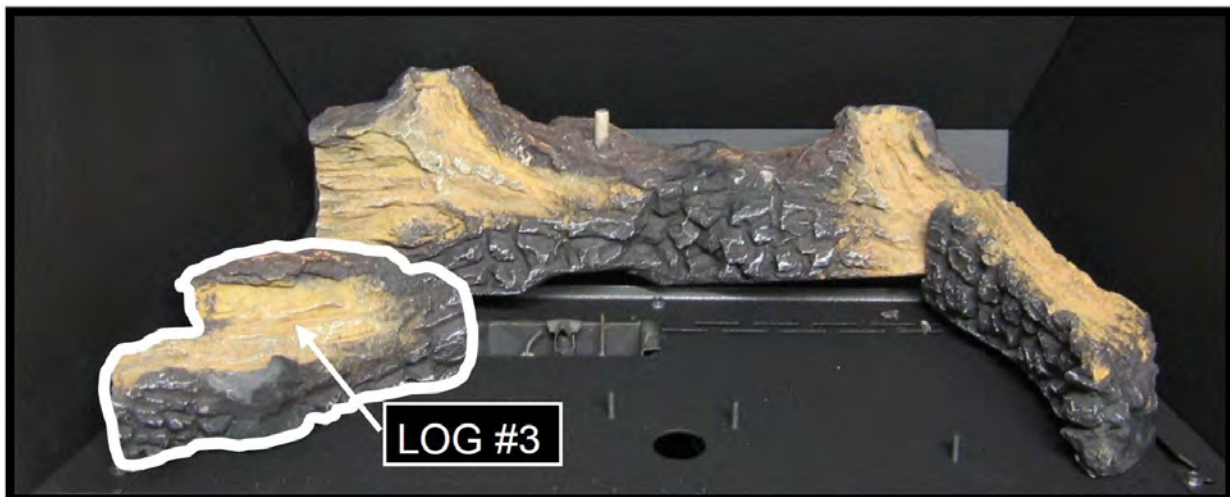

Figure 18.1.04:

Installation

Log #4: Locate Log #4 and align the two holes in the log with the two locator pins in the center of the burner. Push down onto locator pins as shown.



Figure 18.1.05:

Log #5: Locate Log #6 and align the hole in the bottom with the locator pin in the burner. Place the other end of the log in the locator pin of log #2.



Figure 18.1.06:

Log #6: Locate Log #5 and align the hole in the bottom with the locator pin in the burner. Lay the log back top rest against log #2 and log #4.



Figure 18.1.07:

Installation

NOTE

Logs #1, #3 and #4 have been crafted to allow airflow from under the logs. **DO NOT** crush the bottom of the logs to make these sit flush with the top of the burner. Care must also be taken to not completely block the front of the logs with embers.



DO NOT block under log air paths.

Figure 18.1.08:

18.2 Ember Placement

Place black embers around logs as shown, do not completely block the holes in the burner. Do NOT block pilot opening. Failure to keep openings clear could cause a delayed ignition.

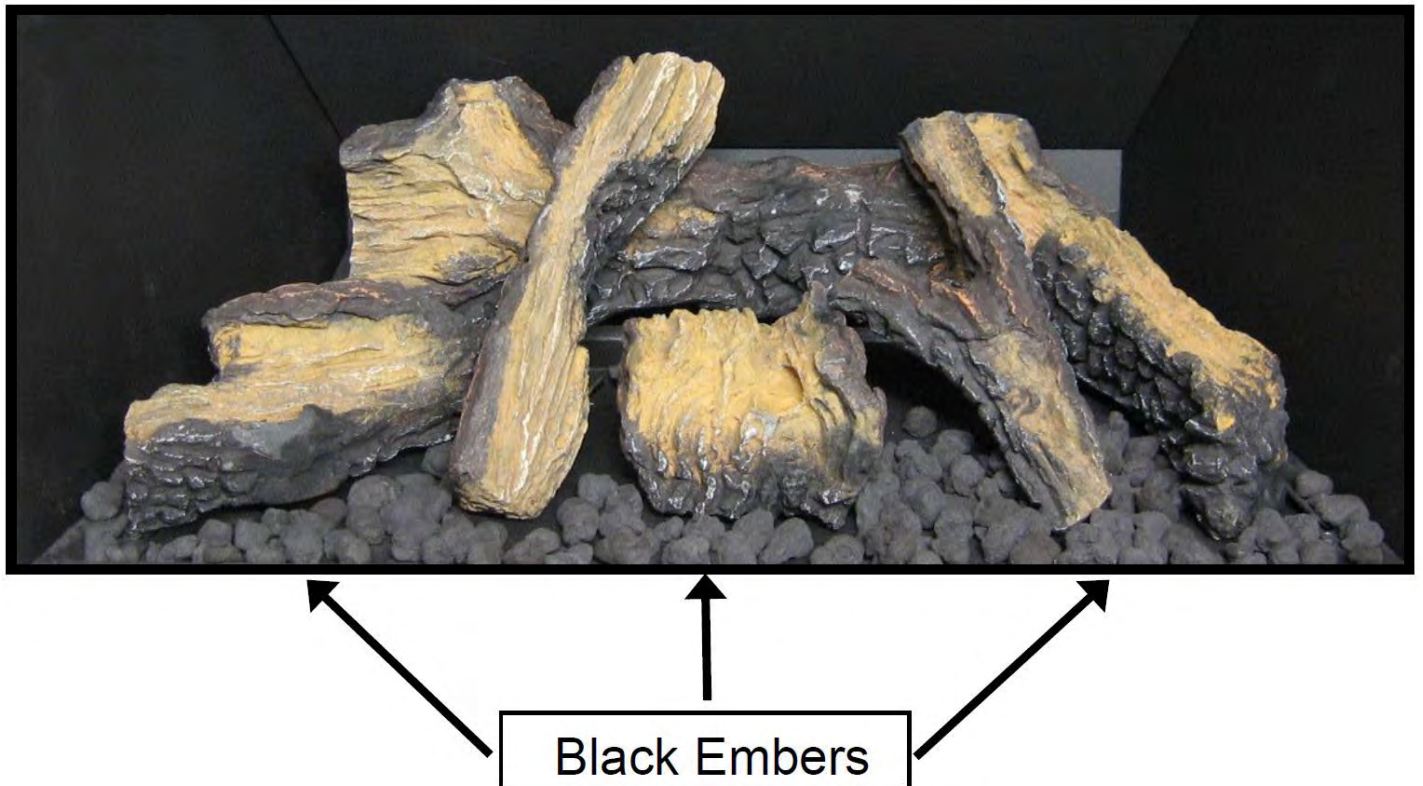

Figure 18.2.01:

Installation

Platinum Ember Placement

Platinum embers provide a brighter glow than the black embers. When using a mixture of both the firebox will be filled with a naturalistic glow. **Note:** DO NOT block burner openings with platinum embers or any other material.

Step 1: Remove embers from the bag. Be sure to follow handling instructions on the bag. Separate embers by pulling apart. Embers may be flattened or separated into smaller pieces to achieve any desired aesthetic.

Step 2: Place the embers randomly throughout the fire bed, taking care to avoid burner openings.



Figure 18.2.02:



Figure 18.2.03:



Figure 18.2.04:

18.3 Complete Log Set

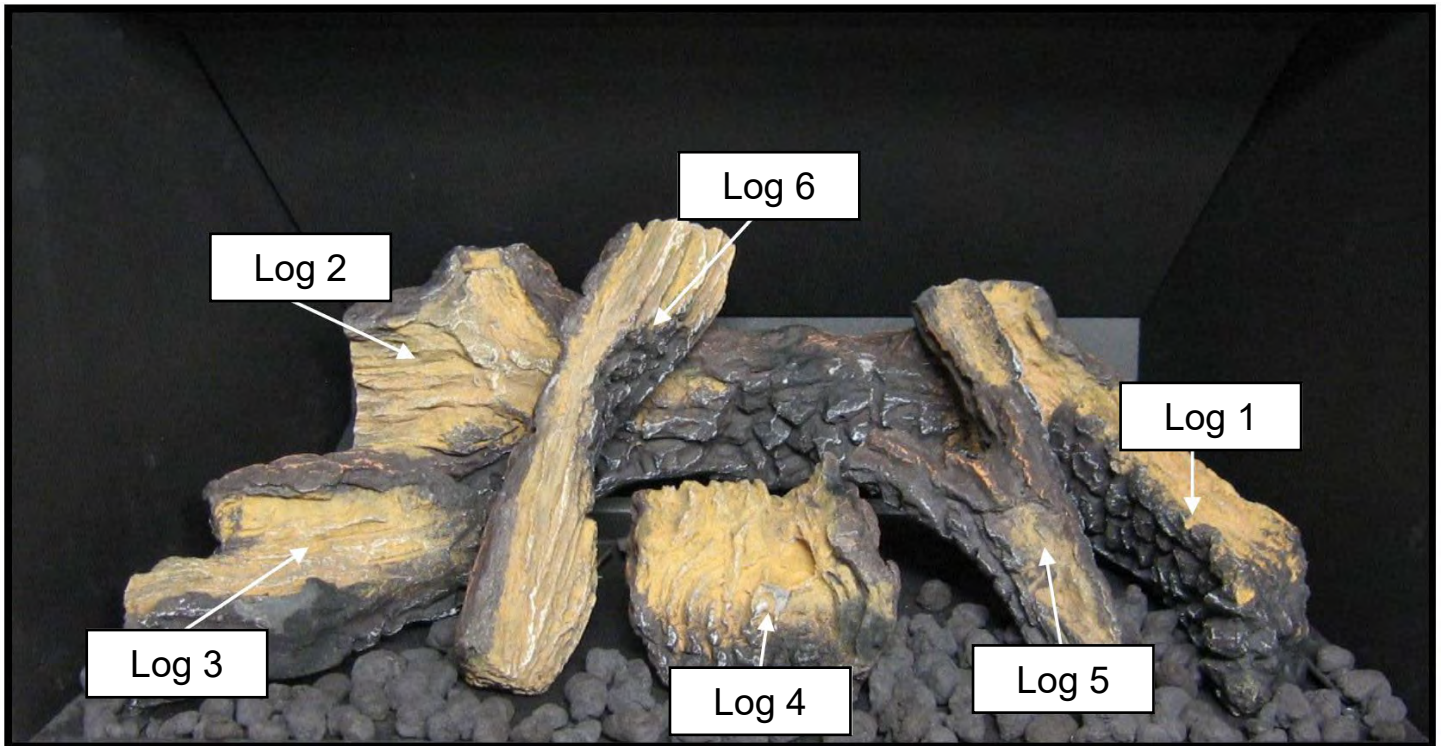

Figure 18.3.01:

Item #	Item Description	Qty	Unit
310-6270	Complete Log Set	1	EA
310-6270-1	Log 1	1	EA
310-6270-2	Log 2	1	EA
310-6270-3	Log 3	1	EA
310-6270-4	Log 4	1	EA
310-6270-5	Log 5	1	EA
310-6270-6	Log 6	1	EA
310-0020	Black Embers (2 cup bag)	1	EA
310-0019	Platinum Embers (1 bag)*	1	EA

*not shown

WARNING

Failure to position the logs in accordance with the preceding diagrams or failure to use only parts specifically approved with this appliance may result in property damage or personal injury. Never use unapproved burner media such as rock wool or similar material.

19.0 Operation

19.1 Before Lighting

WARNING: If you do not follow these instructions exactly, a fire or explosion may result causing property damage, personal injury or loss of life. Do not operate the appliance with the glass front removed, cracked or broken. Replacement of broken glass should be done by a licensed or qualified service person.

Each Archgard Gas Fireplace is checked and tested at the factory prior to being packaged and shipped to our dealers and finally installed in your home. Brigantia recommends that before leaving this unit with the customer, the installer must ensure that the appliance is firing correctly and that the electrical system is in working order. This will include:

1. Performing leak tests of supply line, gas control valve, supply line from gas control valve and pilot assembly.
2. Locking the appliance to ensure the correct firing rate (see **Section 11.1** of this manual).
3. If required, adjusting the primary air to burner to ensure that the flame does not carbon or soot.
4. Checking for proper operation including correct drafting.
5. Turning the fireplace ON (refer to the instructions for FIRST FIRE located in this manual).

Use the installation checklist in **Section 5.0** to ensure all installation steps have been completed.

Note: Any alteration to this product that causes carbon or soot deposits that results in any damage or requires cleaning is not the responsibility of the manufacturer.

Do not store or use gasoline or other flammable vapors and liquids in the vicinity of this or any other appliance.

WHAT TO DO IF YOU SMELL GAS:

- Do not try to light any appliance.
- Do not touch any electrical switch; do not use any phone in your building.
- Immediately call your gas supplier from a neighbor's phone. Follow the gas supplier's instructions.
- If you cannot reach your gas supplier, call the fire department.

Installation and service must be performed by a qualified installer, service agency or the gas supplier.

1. **BEFORE LIGHTING**, smell all around the appliance area for gas. Be sure to smell next to the floor, because some gasses are heavier than air and will settle on the floor.
2. **IF YOU SMELL GAS**, follow the instructions as listed directly above or as shown on the front cover of this manual.
3. Do not use this appliance if any part has been under water. Immediately call a qualified service technician to inspect the appliance and to replace any part of the control system and any gas control which has been under water.
4. This appliance is equipped with an ignition device which automatically lights the pilot and main burner when operating the remote control.

19.2 First Fire

When operated for the first few times, the appliance will emit some odor and fumes. This is due to the heat from the appliance evaporating the oils and solvents used in fabricating the appliance. Close off the room to the rest of the house and open all windows. Keep the room well ventilated, as smoke alarm may sound. Run the appliance for at least 6 hours at maximum setting with blower set to "OFF" to allow paint to cure (after the installer has checked to ensure the fan is operational). Smoke and fumes caused by the curing process may cause discomfort to some individuals. Clean the glass door after this curing process has completed (see **Section 20.1**). Be sure there are no fingerprints left on the glass panels as high temperatures can bake these prints on permanently.

19.3 Lighting Instructions

The following information may be found on the fireplace rating plate. See **Section 6.1** for the rating plate location.

FOR YOUR SAFETY READ BEFORE LIGHTING
POUR VOTRE SÉCURITÉ VEUILLEZ LIRE AVANT L'ALLUMAGE

WARNING: If you do not follow these instructions exactly, a fire of explosion may result causing property damage, personal injury or loss of life.

AVERTISSEMENT: Quiconque ne respecte pas à la lettre les instructions dans la présente notice risque de déclencher un incendie ou une explosion entraînant des dommages, des blessures ou la mort.

A. This appliance is equipped with an ignition device which automatically lights the pilot. Do not try to light the pilot by hand. When lighting the pilot follow these instructions exactly.

B. BEFORE OPERATING smell all around the appliance area for gas. Be sure to smell next to the floor because some gas is heavier than air and will settle on the floor.

WHAT TO DO IF YOU SMELL GAS

- Do not try to light any appliance.
- Do not touch any electrical switch; do not use any phone in your building.
- Immediately call your gas supplier from a neighbor's phone. Follow the gas supplier's instructions
- If you cannot reach your gas supplier, call the fire department.

C. Do not use this appliance if any part has been under water. Immediately call a qualified service technician to inspect the appliance and to replace any part of the control system and any gas control which has been under water.

A. Cet appareil est équipé d'un dispositif d'allumage qui allume automatiquement la veilleuse. N'essayez pas d'allumer la veilleuse à la main.. Respectez les instructions ci-dessous à la lettre.

B. AVANT D'ALLUMER la veilleuse, reniflez tout autour de l'appareil pour détecter une odeur de gaz. Reniflez près du plancher, car certains gaz sont plus lourds que l'air et peuvent s'accumuler au niveau du sol.

QUE FAIRE SI VOUS SENTEZ UNE ODEUR DE GAZ:

- Ne pas tenter d'allumer d'appareil
- Ne touchez à aucun interrupteur; ne pas vous servir des téléphones se trouvant dans le bâtiment
- Appelez immédiatement votre fournisseur de gaz depuis un voisin. Suivez les instructions du fournisseur.
- Si vous ne pouvez rejoindre le fournisseur, appelez le service des incendies.

C. N'utilisez pas cet appareil s'il a été plongé dans l'eau, même partiellement. Faites inspecter l'appareil par un technicien qualifié et remplacez toute partie du système de contrôle et toute commande qui ont été longés dans l'eau.

LIGHTING INSTRUCTIONS
INSTRUCTION D'ALLUMAGE

1. STOP! Read the safety information above on this label. This appliance is equipped with an ignition device which automatically lights the pilot. Do not try to light the pilot by hand.
2. Set the remote control switch to "OFF".
3. Open the lower louvers, or remove trim and barrier screen.
4. Turn off all electric power to the appliance.
5. Open the gas isolation valve.
6. Wait 5 minutes to clear out any gas. Then smell for gas, including near the floor. If you smell gas, STOP! and follow "B" in the safety information above (and to the left) on this label. If you do not smell gas, go to the next step.
7. Turn on all electric power to the appliance.
8. Set the remote control switch to "ON".
9. If the fireplace does not light, the system will cycle through two trials (one minute of audible clicking, thirty seconds of silence, and then another one minute of audible clicking). If the system locks out due to inadequate gas flow, refer to troubleshooting in instruction manual.
10. If the system will not function correctly, follow the instructions "To turn Off Gas To Appliance" below and call your service technician or gas supplier.
11. Replace louver or trim.

1. ARRÊTEZ! Lisez les instructions de sécurité sur la portion supérieure (à droite) de cette étiquette. Cet appareil est équipé d'un dispositif d'allumage qui allume automatiquement la veilleuse. N'essayez pas d'allumer la veilleuse à la main.
2. Réglez le commutateur à distance sur "OFF".
3. Ouvrez persiennes inférieurs ou garnir.
4. Coupez l'alimentation électrique de l'appareil.
5. Vanne d'isolement de gaz ouverte.
6. Attendez cinq (5) minutes pour laisser échapper tout le gaz. Reniflez tout autour de l'appareil, y compris près du plancher, pour détecter un odeur de gaz. Si vous sentez une odeur de gaz, ARRÊTEZ! Passez à l'étape B des instructions de sécurité sur la portion supérieure (à gauche) de cette étiquette. S'il n'y a pas d'odeur de gaz, passez à l'étape suivante.
7. Réglez le commutateur à distance sur "ON".
8. Allumez l'alimentation électrique de l'appareil.
9. Si le foyer ne se allume pas, le cycle de la volonté du système grâce à deux essais (une minute de clic audible, trente secondes de silence, et puis un autre une minute de clic audible). Si le système se bloque en raison de l'écoulement de gaz insuffisante, voir le dépannage dans le manuel d'instruction.
10. Si le système ne fonctionne pas correctement, suivez les instructions «Pour couper le gaz de l'appareil» ci-dessous et appelez votre technicien d'entretien ou fournisseur de gaz.
11. Persienne fermée ou garnir.

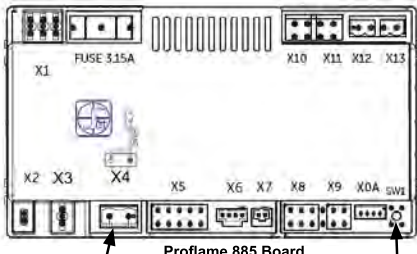

Proflame 885 Board

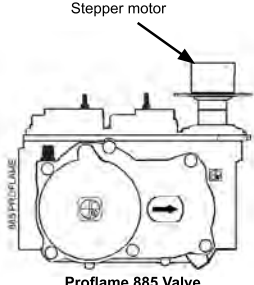

Proflame 885 Valve

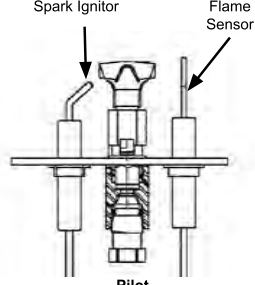

Pilot

TO TURN OFF GAS TO APPLIANCE
POUR COUPER LE GAZ À L'APPAREIL

1. Set the remote control switch to "OFF".
2. Turn off all electric power to the appliance if service is to be performed.
3. Open louver or access panel.
4. Turn incoming gas isolation valve to "OFF" position.
5. Close louver or trim.

1. Réglez le commutateur à distance sur "OFF".
2. Coupez l'alimentation électrique de l'appareil s'il faut procéder à l'entretien.
3. Ouvrez persiennes inférieurs ou porte d'accès.
4. vanne d'isolement de gaz à proximité
5. Persienne fermée ou garnir.

Figure 19.3.01:

44

Archgard
FIREPLACES

19.4 Dynamic Start Advantage

This fireplace comes standard with the Dynamic Start Advantage. This new electronic ignition system is the latest in fireplace technology. It helps to create a better draft, better flame appearance, less condensation on the glass, and years of carefree operation.

How the system works:

When starting a solid fuel wood burning fireplace you build a fire. You start with a little bit of tinder and kindling to create small fire, and then work your way up to larger logs once a draft has been established. Dynamic Start uses the same principle. When you press the "ON" button on the remote control the main burner will light and remain with a low flame for two minutes. This will first establish a draft in the vent and slowly warm up the fireplace. When two minutes have passed, the main burner will automatically ramp up to the high flame (or whichever setting you have established on the remote control).

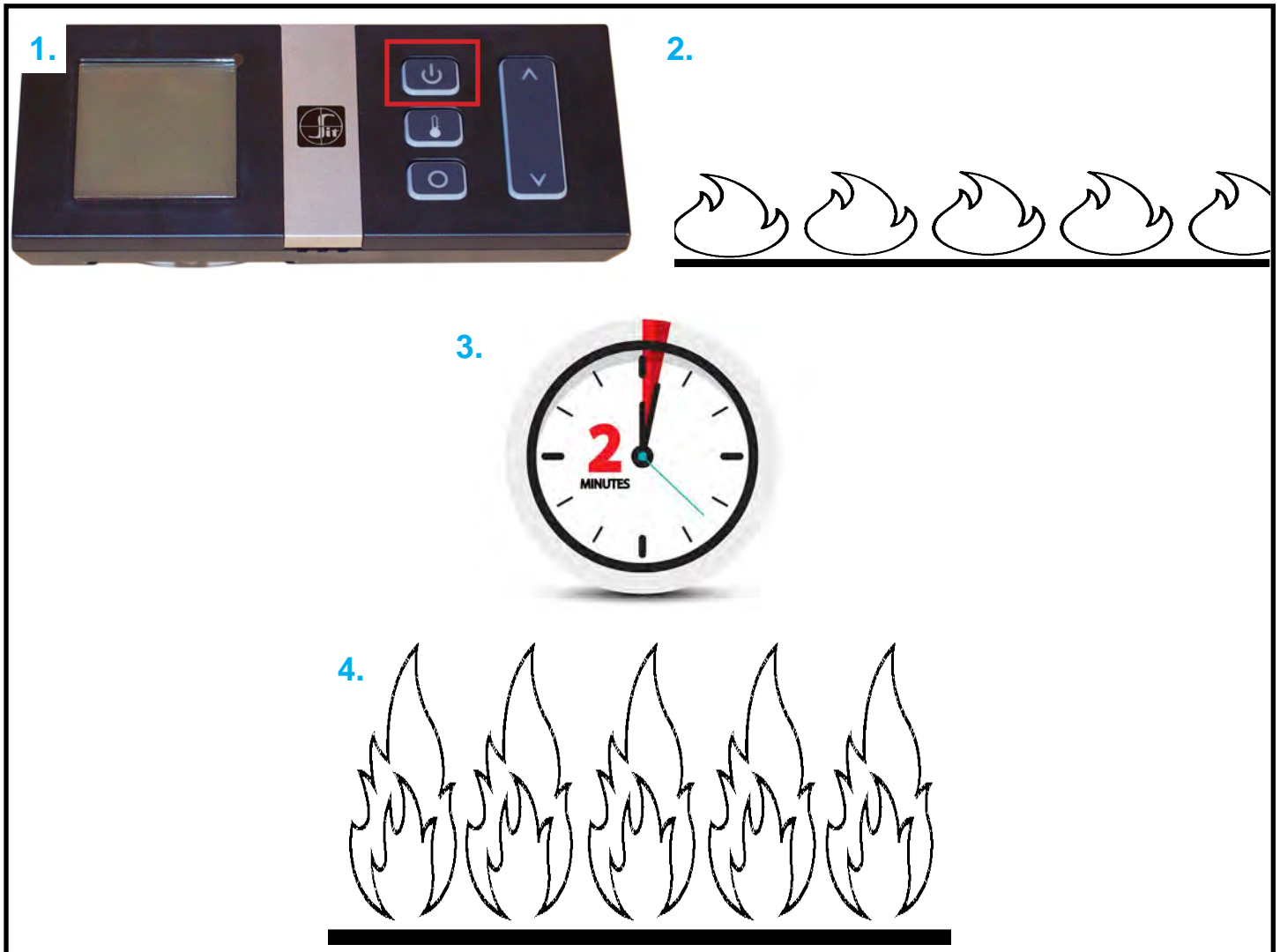

Figure 19.4.01

Operation

19.5 Remote Control Operation

IMPORTANT

The Proflame II Remote is an integrated part of the Proflame II System, which consists of a Proflame II Remote, to be used in conjunction with Integrated Fireplace Control (Proflame II Control Module).



Figure 19.5.01

The Proflame II Remote provides for controlling the following hearth appliance functions:

1. Main Burner ON/OFF
2. Main Burner flame modulation (6 levels)
3. Choice of Continuous Pilot on Demand or intermittent pilot (CPI/IPI)
4. Thermostat and SMART thermostat function
5. Comfort fan speed modulation (6 levels)

The Proflame Remote uses a streamline design with a simple button layout and informative LCD display. A Mode Key is provided to index between the features and a Thermostat Key is used for on/off or to index through the thermostat function. Additionally a Key Lock function is provided.

ATTENTION

- TURN OFF THE MAIN GAS SUPPLY DURING INSTALLATION OR MAINTENANCE OF THE RECEIVER DEVICE
- TURN OFF MAIN GAS SUPPLY TO THE APPLIANCE PRIOR TO REMOVING OR REINSERTING THE BATTERIES
- IN CASE OF REMOTE CONTROL MALFUNCTION TURN OFF THE FIREPLACE BY REMOVING POWER SUPPLY (INCLUDING BACKUP BATTERIES)
- FOR INSTALLATION/MAINTENANCE SWITCH OFF THE FIREPLACE BY REMOVING POWER SUPPLY (INCLUDING BACKUP BATTERIES)

Technical Data - Remote Control

Supply Voltage	4.5 V (three (3) 1.5V AAA batteries)
Ambient temperature ratings	0 - 50°C (32 - 122°F)
Radio Frequency	315 MHz

Operation

Handheld Remote Display

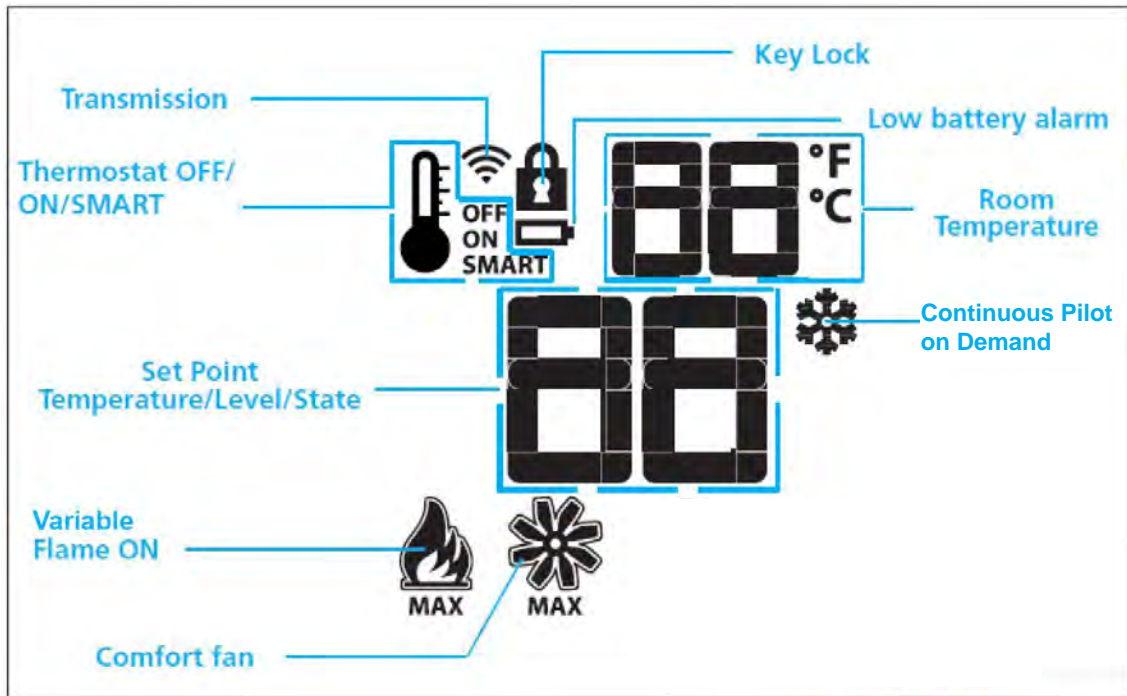

Figure 19.5.02

WARNING

THE REMOTE AND RECEIVER ARE RADIO FREQUENCY DEVICES. PLACING THE REMOTE IN OR NEAR METAL ENCLOSURES MAY REDUCE THE SIGNAL RANGE.

Handheld Remote (optional)



Figure 19.5.03

Operation

Initializing the System for Handheld / Wall Mount Remote Operation

1. Connect IFC Control Module to AC power supply. A single “beep” will indicate the presence of power. **NOTE: This will initiate Pilot Start-up in Manual Mode. The pilot will spark repeatedly and ignite if gas has been supplied to the unit. Sync the control board to the remote to turn main burner and pilot off using the steps below.**
2. The ON/OFF Override Jumper on the control board must be connected.
3. Press and hold the red SW1 button until the IFC module beeps three (3) times and/or the amber LED illuminates indicating the module is ready to synchronize with the remote.
4. Within ten (10) seconds push the ON/OFF key on the remote. The IFC module will “beep” four (4) times to indicate that it has successfully synced with the remote. Turn the fireplace OFF using the ON/OFF button on the remote to complete initialization. The remote will now control the fireplace.
5. Install the provided four (4) AA batteries into battery back up holder.

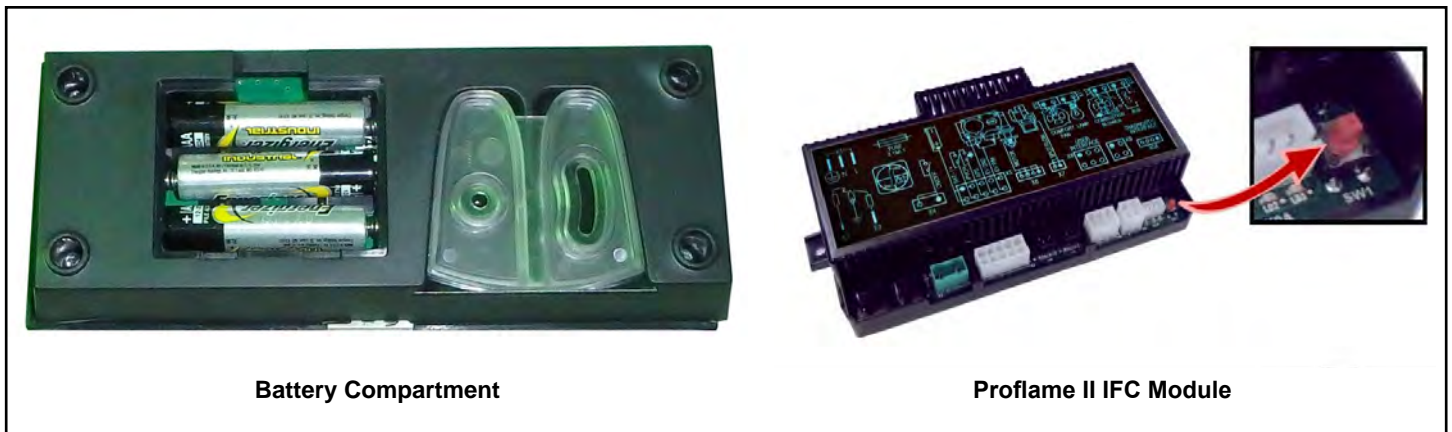

Figure 19.5.04:

Turn "ON" the Appliance

With the system OFF, press the ON/OFF Key on the Remote. The Remote display will show other active icons on the screen. At the same time the Receiver will activate the appliance. A single “beep” from the receiver will confirm reception of the command.

Turn "OFF" the Appliance

With the system ON, press the ON/OFF Key on the Remote. The Remote display will show the current room temperature. At the same time the Receiver will turn the appliance off. A single “beep” from the receiver will confirm reception of the command.

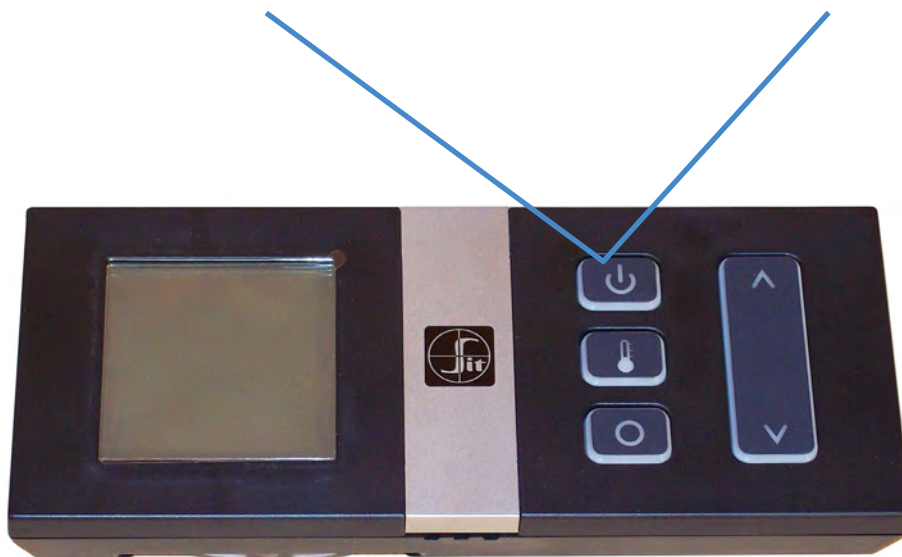

Figure 19.5.05:

Operation

Temperature Indication Display

With the system in the “OFF” position, press the Thermostat Key and the Mode Key at the same time to switch between Fahrenheit (F) or Celsius (C). Verify on the LCD screen the correct designation is visible.

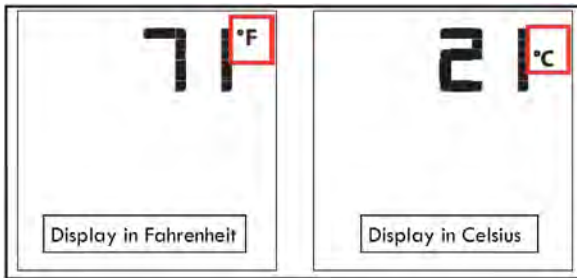

Figure 19.5.06:

Variable Flame Control

This function is disabled when in SMART Thermostat Mode and does not operate in the first two minutes of operation during the Dynamic Start Advantage.

The Proflame IFC has six (6) flame levels. With the system “ON” and the flame at maximum in the appliance, pressing the Down Arrow Key once will reduce the flame height by one step. Repeat to lower the flame till “OFF”. With flame OFF in this configuration, fan will still be operational.

The UP Arrow Key will increase the flame height each time it is pressed.

If the UP Arrow Key is pressed while the system is on but the flame is off, the flame will activate in the high setting.

A single “beep” will confirm reception of the command.

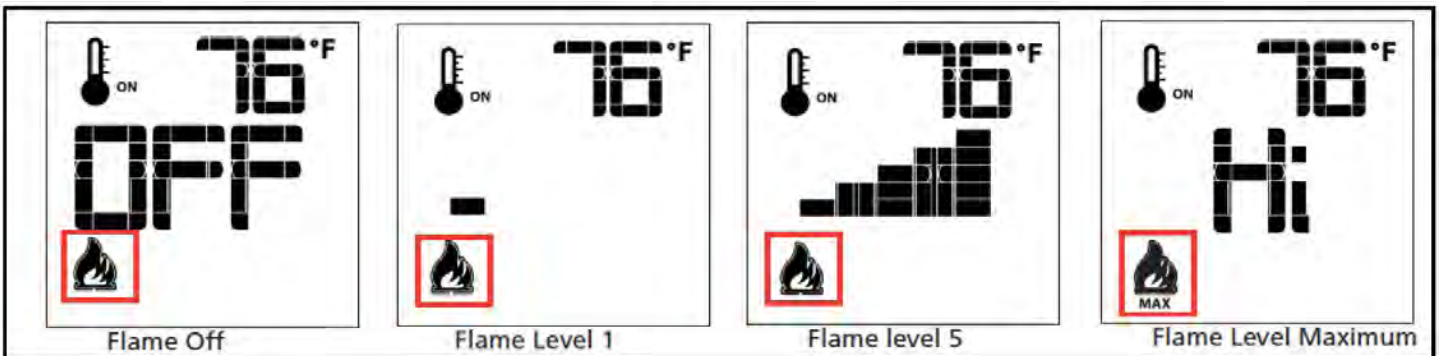

Figure 19.5.07:

Fan Speed Control

If the appliance is equipped with a hot air circulating fan, the speed of the fan can be controlled by the Proflame system. The fan speed can be adjusted through six (6) speeds. To activate this function use the Mode Key to index to the fan control icon. Use the Up/Down Arrow Keys to turn on, off or adjust the fan speed. A single “beep” will confirm reception of the command.

In manual mode the fan will activate immediately upon burner ignition. Adjust the fan speed to personal preference. Blower will shut off when the burner is extinguished.

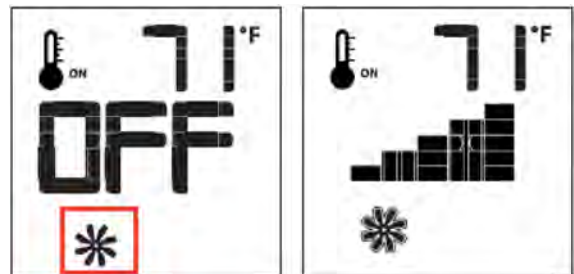

Figure 19.5.08:

Operation

Room Thermostat (Remote Operation)

The Remote Control can operate as a room thermostat. The thermostat can be set to a desired temperature to control the comfort level in a room.

To activate this function:

- Press the Thermostat Key. The LCD display on the remote will change to show that the room thermostat is “ON” and the set temperature is now active
- To adjust the temperature, press the Up/Down Arrow Keys until the desired temperature is displayed

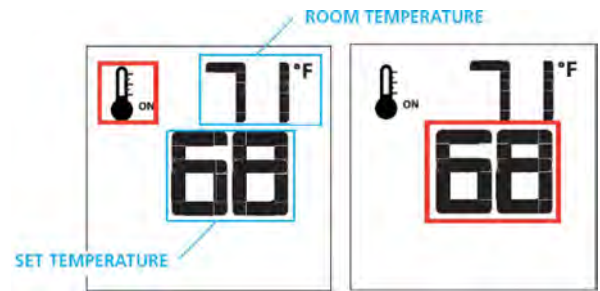

Figure 19.5.09:

SMART Thermostat (Remote Operation)

The Smart Thermostat function adjusts the flame height automatically in accordance to the difference between the set point and the actual room temperature. As the room temperature approaches the set point, the Smart Function will modulate the flame down.

To activate this function:

- Press the Thermostat Key until the word “SMART” appears to the right of the temperature bulb graphic
- To adjust the set temperature, press the Up/Down Arrow Keys until the desired set temperature is displayed

NOTE

When the fireplace is started in Smart Thermostat mode:

1. The fan will automatically activate 5min after ignition and shut down 12min after fire is turned off.
2. Manual Flame height adjustment is disabled.

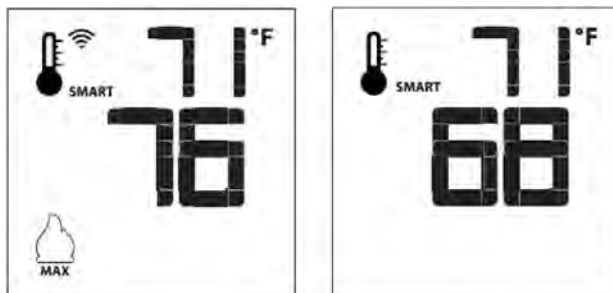

Figure 19.5.10:

Continuous Pilot on Demand / Intermittent Pilot (CPI/IPI) Selection

With the system in “OFF” position press the Mode Key to index to the CPI mode icon.

Pressing the UP Arrow Key will activate the Continuous Pilot on Demand Ignition mode (CPI). Pressing the Down Arrow Key will return to IPI. A single “beep” will confirm the reception of the command.



Figure 19.5.11:

Operation

CPI vs IPI:

Continuous Pilot on Demand Ignition (CPI): In this mode the pilot runs continuously even when the main burner is off. The Continuous Pilot on Demand Ignition operates on a seven day cycle. If the main burner is not turned on for seven continuous days, the pilot will turn itself off. When the main burner is lit again the cycle repeats. The pilot will remain lit for seven days, even after the main burner is turned off. If the main burner is lit during a seven day timing cycle, the seven day timer will reset.

Intermittent Pilot Ignition (IPI): A fuel saving mode in which the pilot is only used when the main burner is on.

This appliance is shipped in IPI mode. IPI mode is often the preferred method, however, there are some situations where it may be preferable to switch the fireplace into CPI mode. For example, in colder climates the glass door or the front of the fireplace could become very cold to the touch. Dynamic Start Advantage will solve most problems experienced by older IPI operated fireplaces.

Automatic Safety Shut-Off

This system will execute an automatic turn OFF command after a 24hr continuous main burner flame ignition. This allows the system to verify correct safety functions.

Diagnostic Indications Information

LOW BATTERY CONDITION (Less than 4V):

Remote Control:

- Battery Icon will appear on LCD remote control display. Replace batteries.

Battery Back-up:

- Red LED indicator will enter a (1) blink sequence. IFC Module will emit a double-beep when it receives an ON/OFF command from the hand held remote. Replace batteries.

Pilot Flame Error Condition:

- Red LED Indicator will commence a (2) blink sequence. Contact your dealer if this occurs.

System Lock Out Condition:

- Red LED Indicator will commence a (3) blink sequence. Make sure your gas is turned on.
- Make sure pilot sensor is not shorted out.
- If the system is in a locked state, reset the IFC module as follows: Turn off all power to the IFC module for at least 2 seconds (including the backup battery pack), then restore power to the IFC module.

Operation

Key Lock

This function will lock the keys to avoid unsupervised operation.

- To activate this function, press the MODE and UP Keys at the same time
- To deactivate this function, press the MODE and UP Keys at the same time

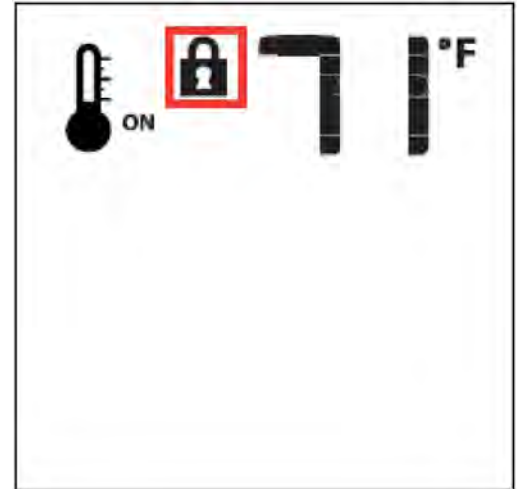

Figure 19.5.13:

Low Battery Power Detection (Less than 4V)

Remote

The life span of the remote control batteries depend on various factors:

- Quality of the batteries used
- The number of ignitions of the appliance
- The number of changes to the room temperature set point, etc

When the Remote batteries are low, a Battery Icon will appear on the LCD display of the Remote before all battery power is lost. When the batteries are replaced this icon will disappear.



Figure 19.5.14:

BACKUP BATTERY PACK (used when 120V home electrical power is interrupted):

- Red LED indicator on the IFC Module will enter a (1) blink sequence
- Backup batteries lifespan depends on various factors including battery quality, number of ignitions, changes to room thermostat set point, etc. When batteries are low, a double beep will be emitted from the IFC control module when it receives an ON/OFF command from the remote control
- This is an alert for a low battery condition of the backup batteries and after this double-beep warning, no commands will be accepted until batteries are replaced
- When batteries are replaced a beep will be emitted from IFC control module as soon as powered

20.0 Maintenance

CAUTION:

Do not conduct maintenance on the appliance while it is operating or while it is still hot. Always verify proper operation after servicing.

20.1 Cleaning the Appliance

The exterior painted surfaces, glass, and metal plated trims may be cleaned with a soft, non-abrasive cloth and water or a suitable, mild, non-abrasive cleaner. Be sure there are no fingerprints left on the glass panels as high temperatures can bake these prints on permanently.

Regularly:

- Frequent cleaning of the ceramic glass is recommended. We recommend using a good quality ammonia free gas fireplace glass cleaner that is available at any hearth retail location. Take care to avoid scratching glass while cleaning. **DO NOT CLEAN WHILE HOT.** Never use common household cleaners to clean the glass.
- Keep the appliance area free from combustible materials, such as paper, wood, clothing, gasoline and flammable solids, liquids and vapors
- Visually check the height and color of the burner and pilot flames
- Touch up the paint if necessary using a high temperature metallic black paint. Allow the paint to dry prior to lighting the fireplace.

Once a year, have a qualified service technician:

- Perform the regular services listed above
- Inspect and operate the pressure relief mechanism (door buckles) to verify they are free from obstruction and operate properly
- Carefully remove the logs and gently brush off any loose carbon deposits. This job is best done outside the house, wearing a dust mask. The logs are very fragile, take care not to break them. Do not wash logs with any liquid. While the logs are removed, check that all burner openings are not obstructed and it is recommended you use a vacuum cleaner to clean off any dust or lint
- Vacuum and clean any lint accumulations or debris in the firebox, on the burners, on the pilot, at the primary air opening, on the convection air blower and in any combustion and convection air passageways
- After cleaning, the logs and embers must be replaced according to the instructions in this manual
- Inspect the operation of the flame safety system pilot and gas valve
- Inspect and ensure the lighting of the main burner occurs within 4 seconds of the main gas valve opening. Flames should match those shown in **Figure 20.4.01** and **Figure 20.5.01**
- Completely inspect the appliance and the venting system, if the vent pipe or seal is found to be defective, replace and or reseal (follow the instructions found in the venting instructions, **Section 13.0**)
- Inspect the condition of the vent and vent terminal for sooting or obstruction and correct if present
- Test and measure the flame failure response time of the flame safety system. It must de-energize the safety shutoff in no more than 30 seconds
- Check all accessible gas-carrying tubes, connections, pipes and other components for leaks

WARNING: All parts removed or disturbed, including guards and grills, must be properly replaced after maintenance. Service and repair must be conducted by a qualified service person. If these instructions are not followed, a fire or explosion may result, causing property damage, personal injury or loss of life.

20.2 Servicing Under Warranty

All service work under warranty must be conducted by a qualified Archgard service technician. Before servicing, read the terms and conditions of the warranty at the back of this manual. Contact the authorized Archgard dealer where you purchased the appliance from and provide them with details of the problem, along with the initial installation information (from the front of this manual).

WARNING: Servicing of this appliance **must be conducted by a qualified Archgard service technician**. Improper servicing, adjustment or alteration of this appliance may cause property damage, personal injury or loss of life. All servicing should be conducted with the appliance cold. All replacement parts must be authorized by Archgard for suitability.

20.3 Checking Inlet and Outlet Pressure

1. Remove the surround.
2. The pressure test taps are located on the valve's front face. The inlet is marked 'IN' and the outlet is marked 'OUT'. See **Figure 20.3.01**.
3. Loosen the set screw inside the tap with a screwdriver.
4. Connect a 1/4" (6 mm) rubber tube to the tap post and a manometer.
5. Verify that the readings obtained are within specs (as shown on the appliance rating plate)
6. Be sure to tighten the set screw inside the tap after you have finished taking pressure readings.
7. Check for leaks.

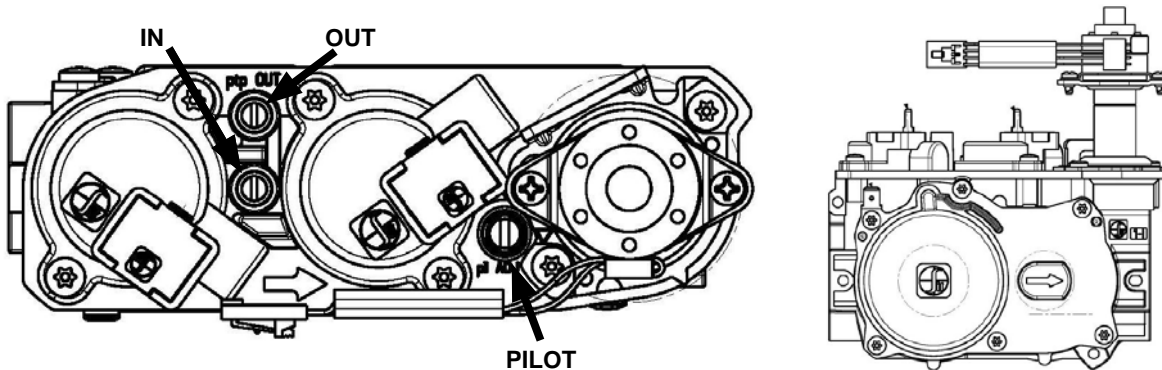

Figure 20.3.01

20.4 Checking and Adjusting Pilot

The pilot flames should have the characteristics shown in the illustration to the right.

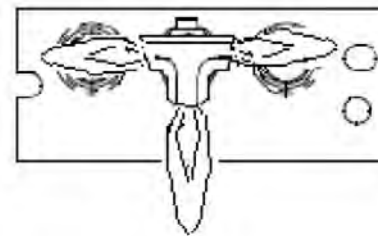

Figure 20.4.01

The flame should not have yellow tips but should engulf the flame sensor and spark electrode. It can be adjusted by turning the screw marked "pilot" on the control valve (See **Figure 20.3.01**).

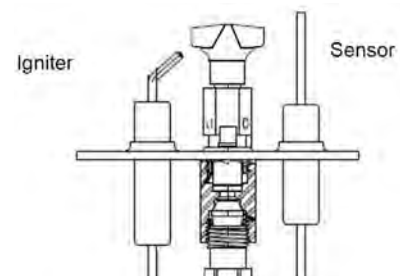

Figure 20.4.02

Maintenance

20.5 Adjusting the Primary Air

NOTE: Figure 20.5.01 shows examples of what a correct or incorrect flame pattern looks like. It is not a true representation of what the 27-DVIE22N-2 will look like in your home environment. The air shutter can be adjusted from the front of the unit while in operation. All adjustments should be made after 20 minutes of operation.

1. Locate the Robertson screw below the glass door and left of center.
2. Turn the screw clockwise to give more air (less yellow flame). Turn the screw counter clockwise to give less air (more yellow flame).

CAUTION: Do not adjust primary air below specified opening on the rating plate.

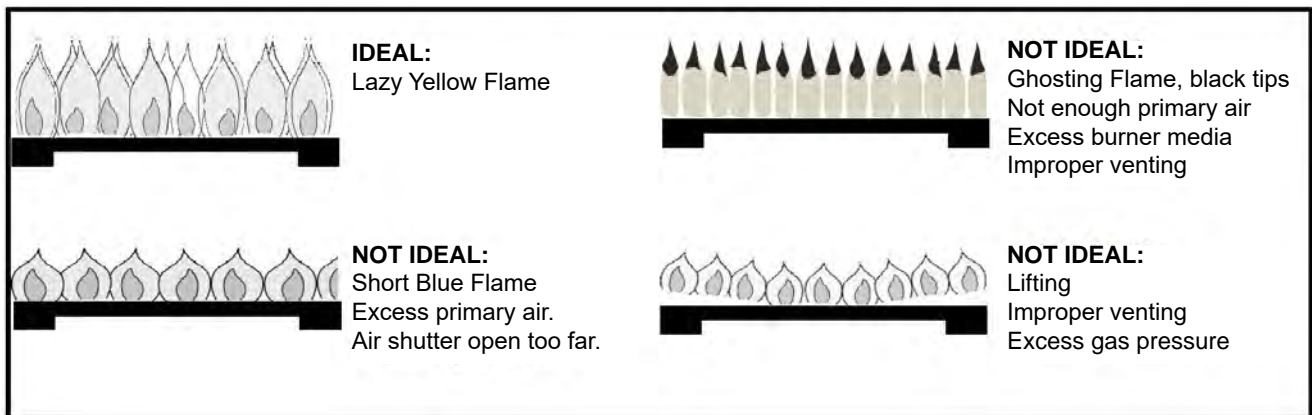

Figure 20.5.01:

20.6 Replacing Batteries

1. Disconnect power supply to the fireplace.
2. Ensure the fireplace is off and cool before servicing.
3. Remove the fireplace surround.
4. Remove the battery holder from the velcro strap on the control board.
5. Remove the expired batteries and replace.
6. Wrap the battery holder neatly in the velcro strap on the control board
7. Replace the surround and resupply power.
8. Light the fireplace to verify proper operation.

Battery Specifications: 4 x AA Batteries

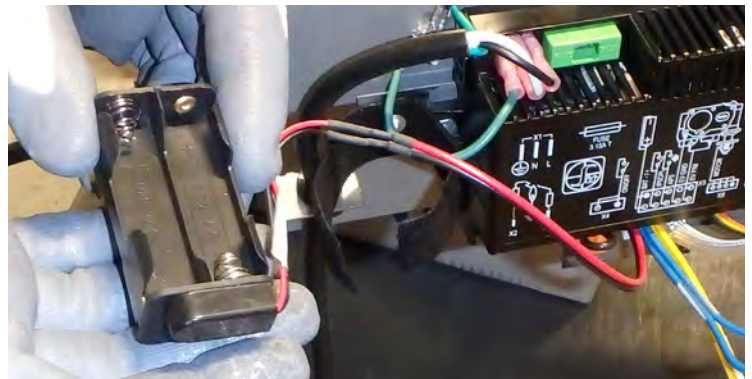

Figure 20.6.01:

20.7 Replacing Fuse

1. Disconnect power supply to the fireplace.
2. Ensure the fireplace is off and cool before servicing.
3. Remove the fireplace surround.
4. Remove fuse holder using needle nosed pliers (if necessary).
5. Replace the fuse with one which has the same specifications using the existing fuse holder.
6. Replace the fuse holder
7. Replace surround and resupply power.
8. Light the fireplace to verify proper operation.

Fuse type: T3.15AL250V

Archgard Part Number: RP-305-2080

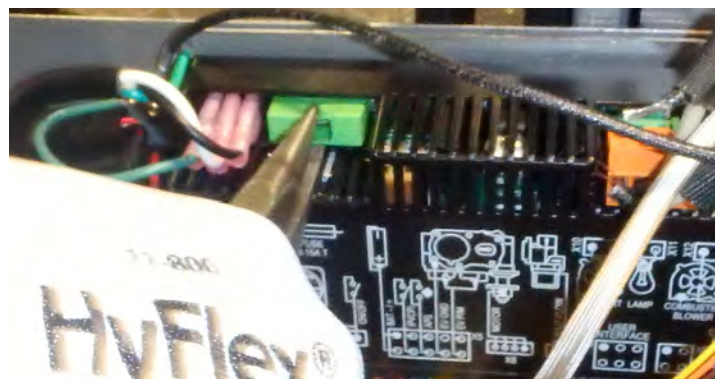

Figure 20.7.01:

20.8 Replacing the Control Board

CAUTION: Label all wires prior to disconnection when servicing controls. Wiring errors can cause improper and dangerous operation. Verify proper operation after servicing.
This appliance, when installed, must be electrically grounded in accordance with local codes or, in the absence of local codes, with the **National Electrical Code, ANSI/NFPA 70, or the Canadian Electrical code, CSA C22.1.**

1. Disconnect power supply to the fireplace.
2. Ensure the fireplace is off and cool before servicing.
3. Remove the fireplace surround.
4. Label all wires connected to the control board.
5. Disconnect all wires connected to the control board.
6. Remove nuts securing the control board at each end.

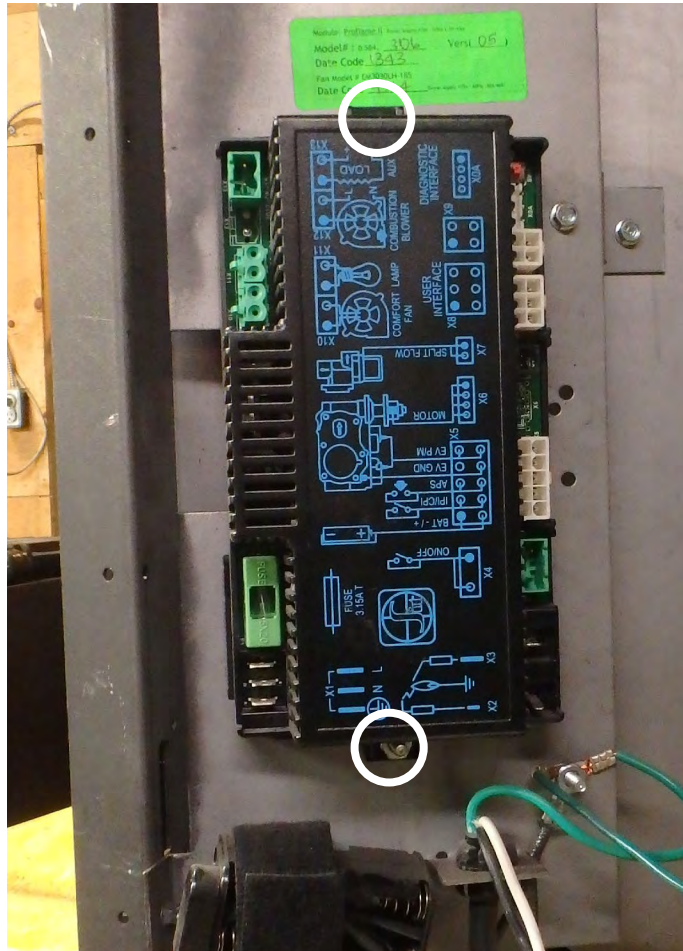

Figure 20.8.01:

7. Install new control board using nuts previously removed.
8. Reconnect wires. ensure all wiring is correct as labeled in step 4 above.
9. Replace surround and resupply power.
10. Light the fireplace to verify proper operation.

20.9 Replacing the Valve

Before you begin:

- Disconnect power and gas supply to the fireplace.
- Ensure the fireplace is off and cool before servicing.
- Remove the fireplace surround.

Installation is the reverse of removal.

1. Unplug the valve motor from the wiring harness and unplug any wires from the valve.

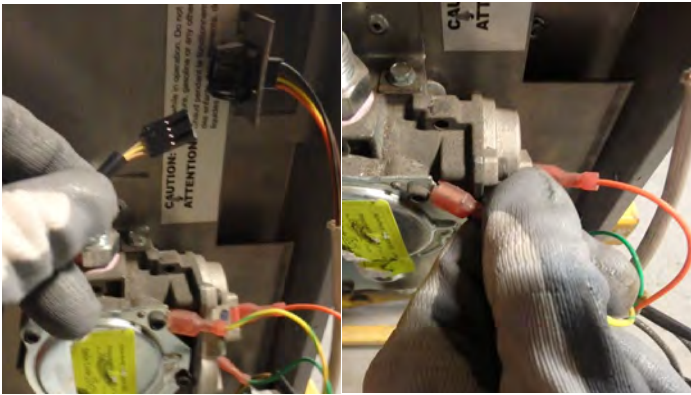

Figure 20.9.01:

3. Remove the pilot gas line.

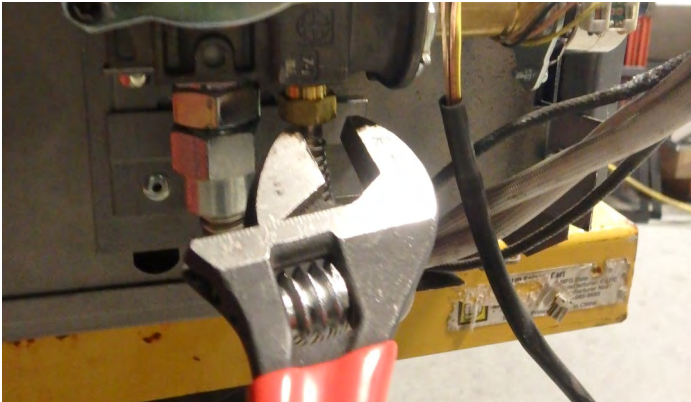

Figure 20.9.03:

5. Lift the valve from the retaining bracket.

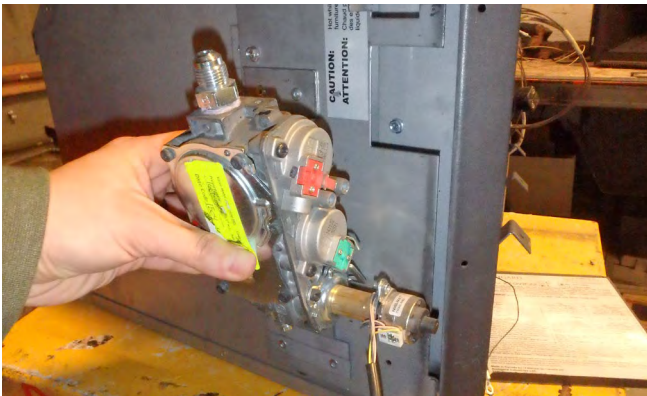

Figure 20.9.05:

CAUTION: Label all wires prior to disconnection when servicing controls. Wiring errors can cause improper and dangerous operation. Verify proper operation after servicing. This appliance, when installed, must be electrically grounded in accordance with local codes or, in the absence of local codes, with the **National Electrical Code, ANSI/NFPA 70, or the Canadian Electrical code, CSA C22.1.**

2. Remove the burner gas line.

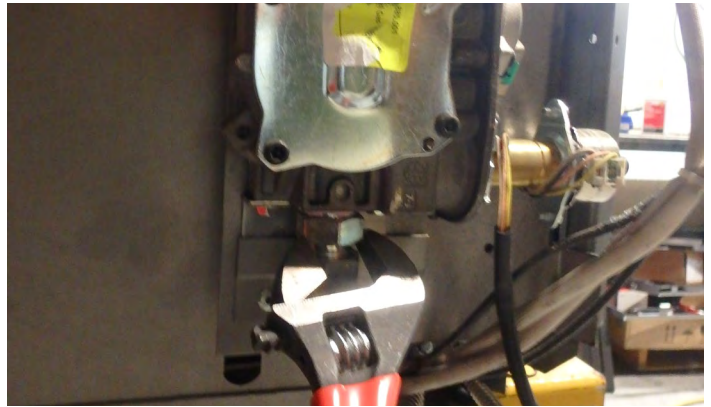

Figure 20.9.02:

4. Remove the (2) screws securing the valve on top.

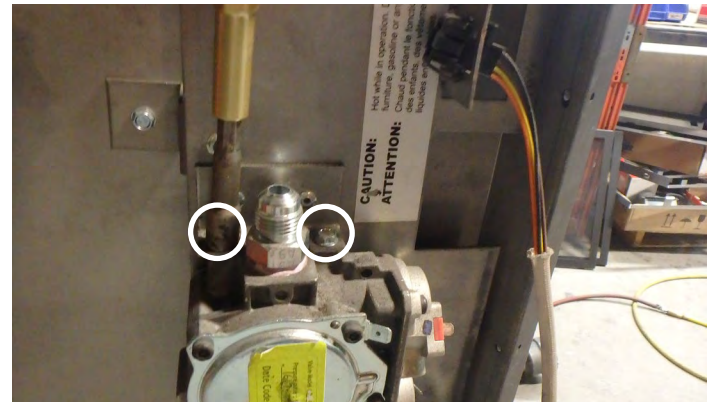

Figure 20.9.04:

6. Remove the lower valve bracket and add to the new valve using screws previously removed.

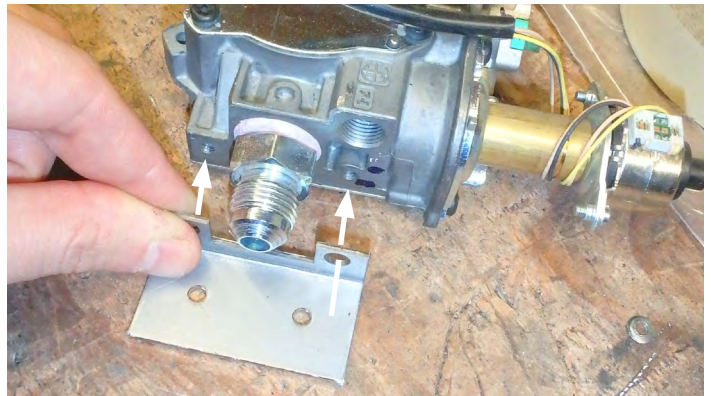

Figure 20.9.06:

20.10 Replacing the Burner

Before you begin:

- Disconnect power and gas supply to the fireplace.
- Ensure the fireplace is off and cool before servicing.
- Remove the barrier screen and door.
- Remove log set and embers.
- Remove brick panels.

1. Remove the pilot shield.



Figure 20.10.01:

2. Remove the burner retainer brackets on the left and right sides of the fireplace.



Figure 20.10.02:

3. Remove the shield at the front of the burner.



Figure 20.10.03:

4. Remove the screws securing the burner on the bottom of the lower baffle.



Figure 20.10.04:

5. Remove the burner by lifting the right side up at an angle and away from the fireplace.



Figure 20.10.05:

Installation is the reverse of removal.

20.11 Replacing the Pilot

CAUTION: Label all wires prior to disconnection when servicing controls. Wiring errors can cause improper and dangerous operation. Verify proper operation after servicing.
This appliance, when installed, must be electrically grounded in accordance with local codes or, in the absence of local codes, with the **National Electrical Code, ANSI/NFPA 70, or the Canadian Electrical code, CSA C22.1.**

Before you begin:

- Disconnect power and gas supply to the fireplace.
- Ensure the fireplace is off and cool before servicing.
- Remove the barrier screen and door.
- Remove log set and embers.
- Remove brick panels.

1. Disconnect the pilot wires from the control board. Note the orientation to ease reinstallation.

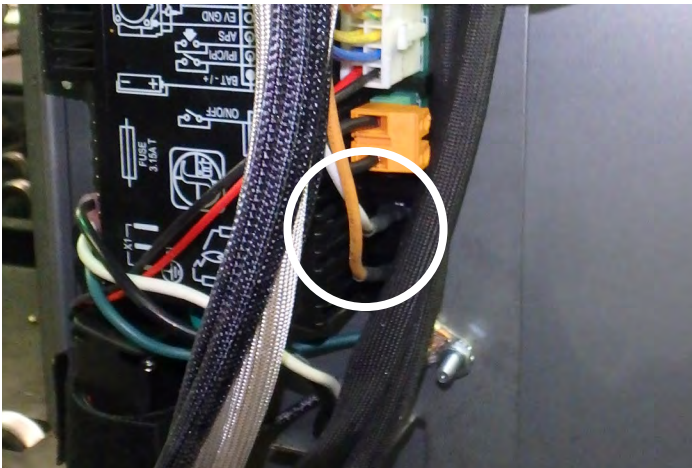

Figure 20.11.01:

3. Pull the pilot up. Remove the tek screw securing the ground wire to the pilot.



Figure 20.11.03:

Note: It is possible to remove the pilot after removing the burner. The burner must be removed in order to install the new pilot.

The following steps show removal of the pilot prior to removal of the burner.

2. Remove the two screws securing the pilot.



Figure 20.11.02:

4. Remove the pilot gas line using a 7/16" wrench.

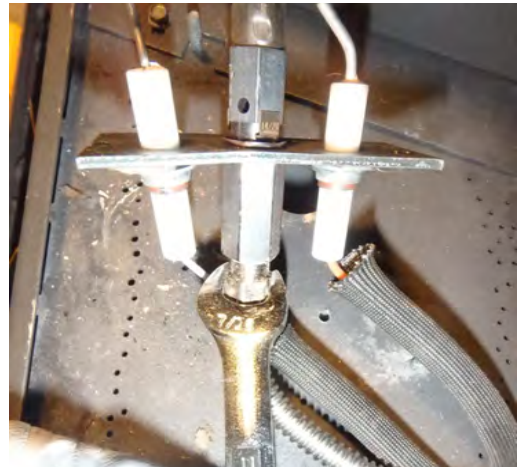

Figure 20.11.04:

Maintenance

5. Clip the zip ties securing the cables.



Figure 20.11.05:

6. Remove the pilot.



Figure 20.11.06:

7. Remove the burner (see **Section 20.10**).



Figure 20.11.07:

8. Remove the (3) screws securing the top of the lower baffle.



Figure 20.11.08:

9. Remove the (2) screws securing the bottom of the lower baffle.



Figure 20.11.09:

10. Remove the lower baffle.



Figure 20.11.10:

Maintenance

11. Remove the (10) 1/4 " hex head screw securing the access cover.

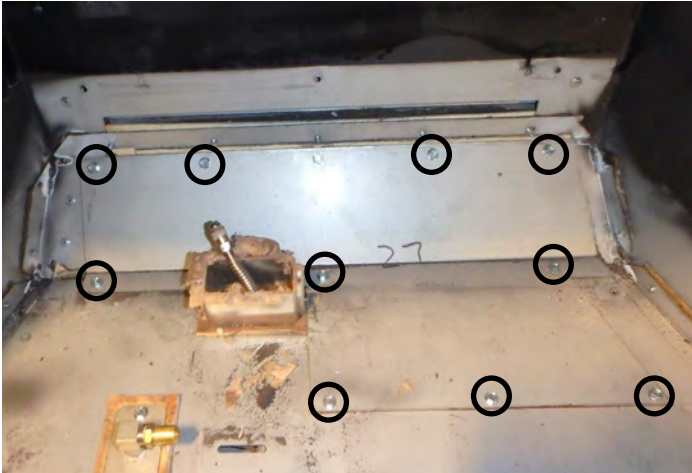

Figure 20.11.11:

12. Remove the access cover.

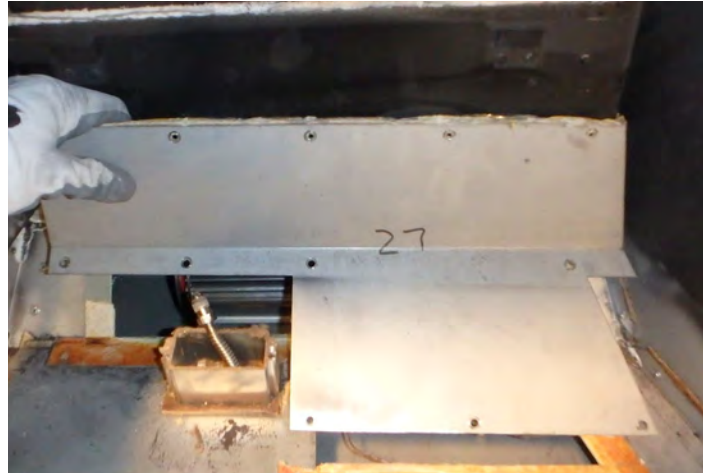

Figure 20.11.12:

13. Thread the wires on the new pilot through the pilot extrusion.



Figure 20.11.13:

14. Thread the wires through the opening on the bottom right side of the fireplace.

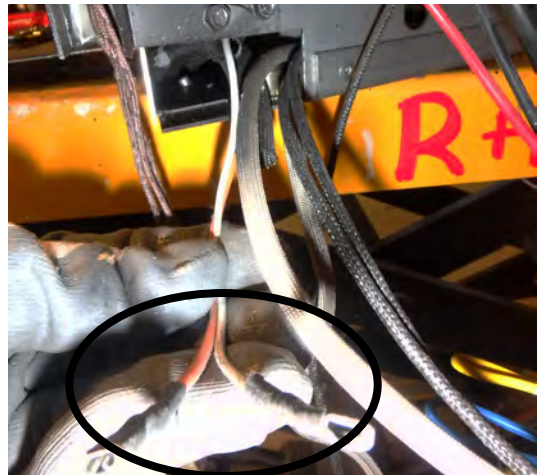

Figure 20.11.14:

15. Replace any gaskets on the pilot and access cover when installing the new pilot.
16. Check for any leaks at all gas connections after installing the new pilot.

Installation is the reverse of removal.

20.12 Replacing the Fan

CAUTION

Label all wires prior to disconnection when servicing controls. Wiring errors can cause improper and dangerous operation. Verify proper operation after servicing.

This appliance, when installed, must be electrically grounded in accordance with local codes or, in the absence of local codes, with the **National Electrical Code, ANSI/NFPA 70**, or the **Canadian Electrical code, CSA C22.1**.

NOTE

- **Make sure the gas to the appliance has been shut off**
- **Ensure that the main power and breaker system is turned off before removing the fan**
- **Make sure the fireplace has been turned off and is cool to the touch**
- **Mark all wires to be removed for proper reassembly**

The convection fan can be accessed either through the front or through the back of the insert.

To Access From the Front

1. Remove the glass door. Follow GLASS DOOR REMOVAL instructions within this manual.
2. Carefully remove the Logs and Burner media.
3. Remove the pan burner. Follow instructions in **Section 20.10**.
4. Remove the access cover (section set at 45 degree angle) of the firebox by removing the (10) 1/4 " hex head screws.
5. Disconnect the wires.

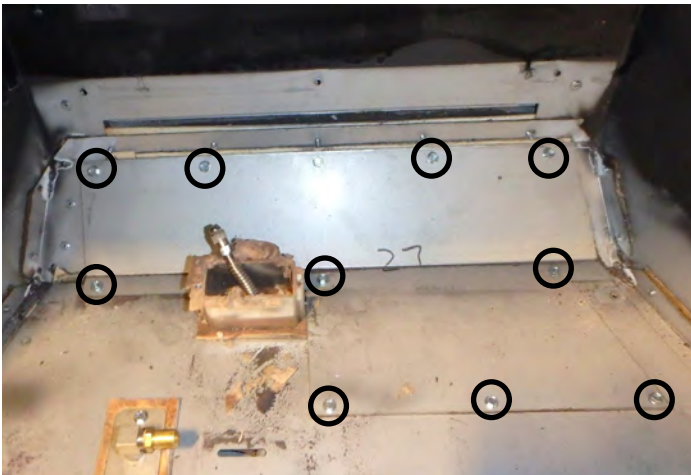

Figure 20.12.01:

6. Remove the four nuts holding the fan in place.

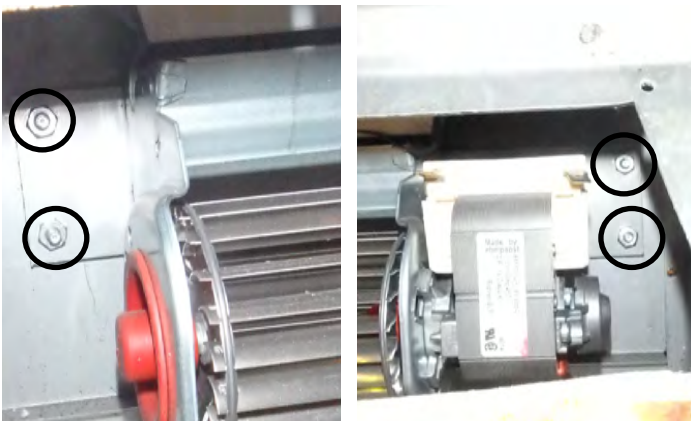

Figure 20.12.03:



Figure 20.12.02:

7. Replace any gaskets on the access cover when installing the new fan.
8. Verify proper operation of the new fan after installation is complete.

Installation is the reverse of removal.

Maintenance

CAUTION

Label all wires prior to disconnection when servicing controls. Wiring errors can cause improper and dangerous operation. Verify proper operation after servicing.
This appliance, when installed, must be electrically grounded in accordance with local codes or, in the absence of local codes, with the **National Electrical Code, ANSI/NFPA 70**, or the **Canadian Electrical code, CSA C22.1**.

NOTE

- **Make sure the gas to the appliance has been shut off**
- **Ensure that the main power and breaker system is turned off before removing the fan**
- **Make sure the fireplace has been turned off and is cool to the touch**
- **Mark all wires to be removed for proper reassembly**

To Access From the Back

1. Remove the surround by lifting up and forward.
2. Disconnect the gas line.
3. Disconnect the intake and exhaust liners
4. Remove the insert from the fireplace.
5. Remove (5) 1/4" hex head screws and the cover plate at the back of the insert.
6. Disconnect the wires.

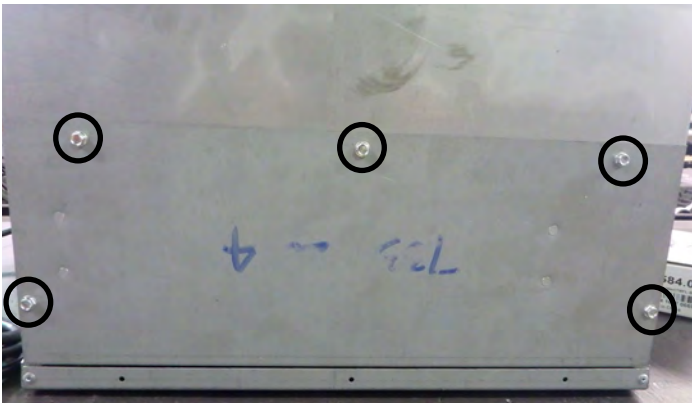

Figure 20.12.04:

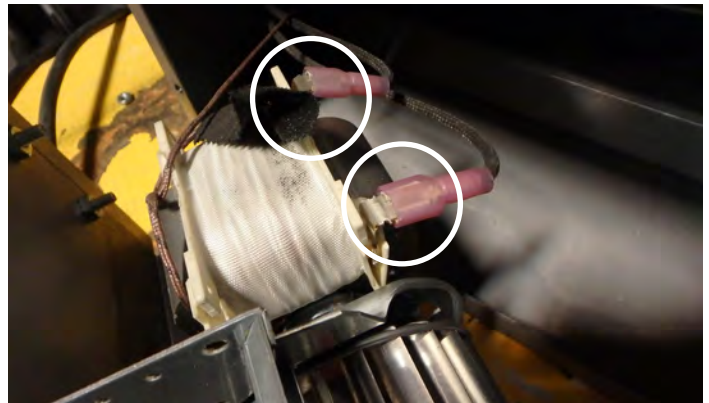

Figure 20.12.05:

7. Remove the (4) 1/4" hex head screws holding the fan bracket.

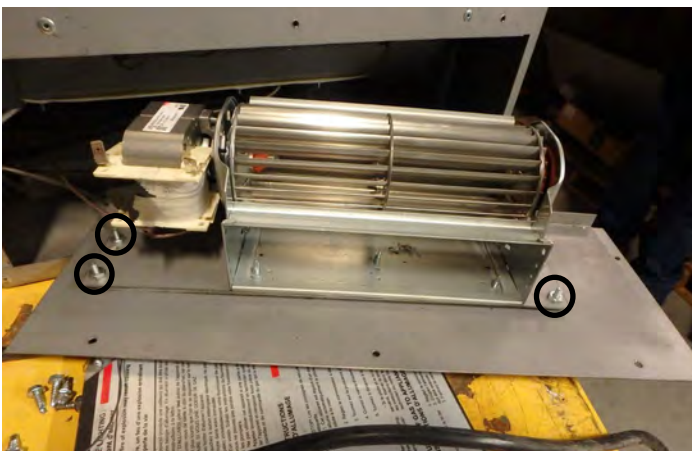

Figure 20.12.06:

8. Check for any leaks at all gas connections after installing the new fan.
9. Verify proper operation of the new fan.

Installation is the reverse of removal.

20.13 Wiring Schematic

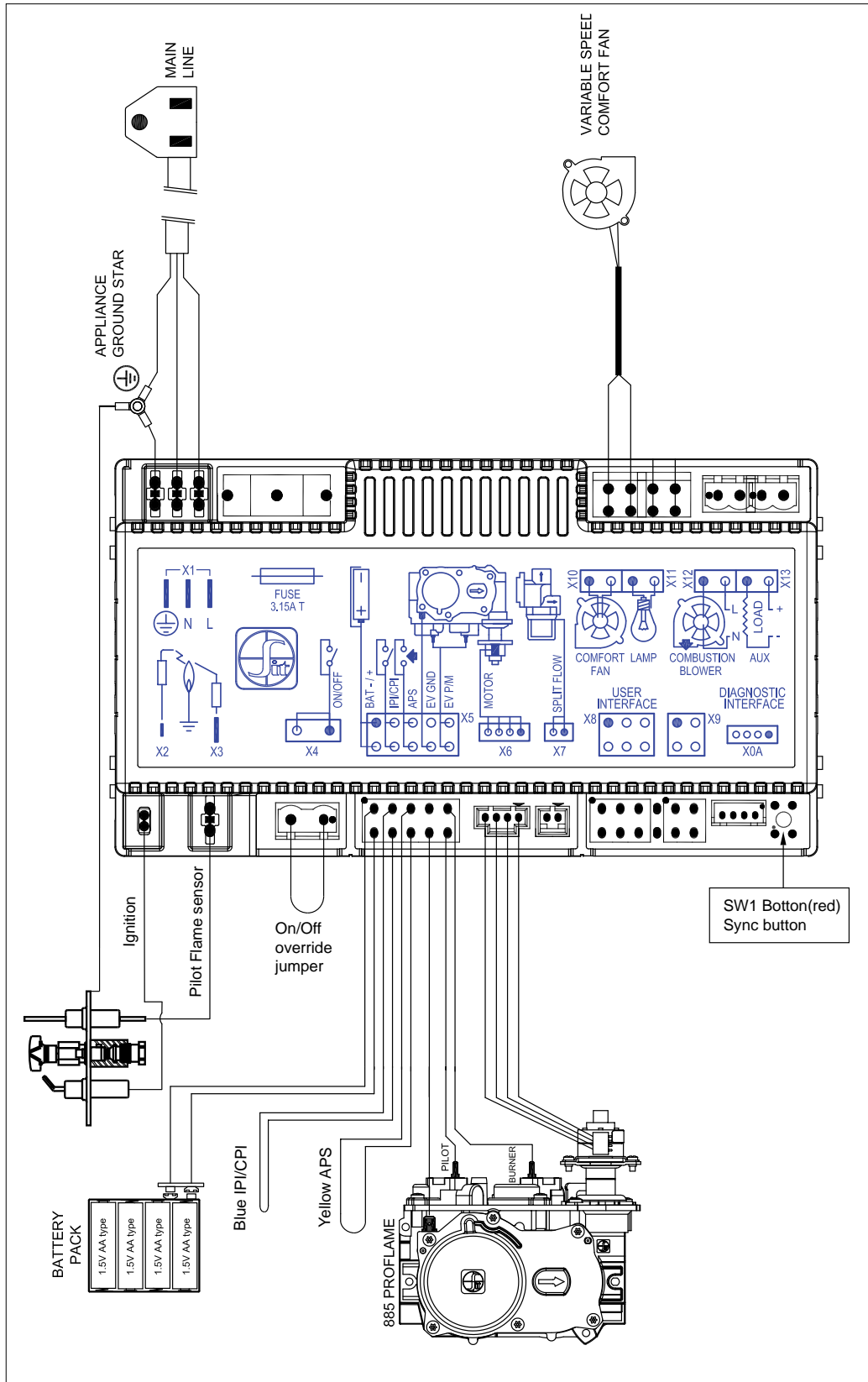

Figure 20.13.01

Maintenance

20.14 Troubleshooting

Issue	Solution
The pilot igniter won't spark.	<ol style="list-style-type: none"> 1. Ensure the ON/OFF override jumper is installed correctly. 2. Ensure main power is ON and new batteries are installed in the remote control (3 x AAA) and backup battery pack on the control board (4 x AA). 3. Make sure remote is synced with control board. 4. Check the 3.15A fuse in the control board. Replace the fuse if necessary. 5. Make sure remote is not in smart or thermostat mode. 6. Ensure igniter wire is connected to the control board and is not damaged.
The pilot igniter sparking, but the pilot will not light.	<ol style="list-style-type: none"> 1. Verify the inlet gas pressure is within acceptable limits. 2. Check all connections to the gas valve. 3. Ensure fuel supply valves and emergency shut-off valve are open. 4. Check wiring connections from control board to valve. 5. Check that the pilot is set to the correct fuel. 6. Ensure pilot head is clear of debris.
The pilot lights, but the main burner will not light.	<ol style="list-style-type: none"> 1. Check and verify all wiring connections match the wiring diagram. 2. Verify the inlet and manifold pressure are within acceptable limits.
The pilot lights, but the main burner will not light and igniter continues to spark.	<ol style="list-style-type: none"> 1. Check the pilot flame sensor rod and clean with steel wool or similar if dirty. 2. Check the pilot hood and clean with steel wool if dirty. 3. Ensure the flame sensor wire is plugged into the control board and is not damaged. 4. Adjust pilot flame using the pilot adjustment screw if the pilot flame is too long or too short (the flame should fully engulf the sensor rod and must be stable). 5. Check supply pressure. 6. Ensure the ground wire from the pilot is connected to the fireplace ground location.
The pilot was lit but will randomly go out.	<ol style="list-style-type: none"> 1. Turn the fireplace on again. If the fireplace is in continuous pilot on demand ignition mode, the system will turn off the pilot if the fireplace has not been used for seven days. You may also switch the fireplace to IPI mode (See Section 19.5). 2. Have a service technician check for low inlet pressure.
The flames on the main burner are low even though the remote is on high.	<ol style="list-style-type: none"> 1. Wait two minutes. Dynamic Start Advantage is designed to build a draft by starting on low and automatically increasing the flame size to the setting on the remote after two minutes. This system helps to create a better flame appearance, reduce condensation on the glass, and provide years of carefree operation. 2. Have a service technician check for low inlet pressure. 3. Replace the valve motor.
Fans do not work.	<ol style="list-style-type: none"> 1. Ensure main power is ON and the fireplace is plugged in (the fireplace may be operating on back up batteries). 2. Check the 3.15A fuse in the control board and replace if necessary. 3. Ensure the fans are connected to the control board.
Control module beeps twice when On/Off button on remote is pressed and Red LED is On.	<ol style="list-style-type: none"> 1. Replace batteries in remote battery pack.

All service and repairs should be performed by a qualified and licensed service technician.

21.0 Frequently Asked Questions

Listed below are some frequently asked questions regarding Archgard Gas Fireplaces. If you have questions that are not listed below, or are not answered in this manual, please contact your Authorized Archgard Dealer.

Q. My glass has a condensation “fog” when the appliance is first lit.

A. Condensation is normal and will disappear in a few minutes after the glass is heated. This can be reduced if the appliance is left in CPI mode.

Q. I have a white “film” on my glass. What is the best way to clean the inside of the glass.

A. Frequent cleaning of your glass is recommended. We recommend using a good quality “gas fireplace” glass cleaner that is available at all authorized dealers. Do not use abrasive materials, and do not clean the glass or the appliance when the unit is hot.

Q. How do I care for my surround.

A. We recommend a cleaning with a damp cloth. DO NOT use chemical cleaners as they may harm the finish, and void your warranty.

NOTE: If the top of the surround starts to discolor, check the door gasket seal and contact your local Archgard dealer to replace if necessary.

Q. My fan/blower makes a “whirring” or “humming” noise.

A. Your Archgard gas appliance uses a powerful fan to push heated air into your room. It is not unusual to hear a “humming” noise when your fan is running. Note: the sound will change depending on the setting that your fan speed control is set at.

Q. I hear a “ticking”, “cracking” or “pinging” sound when my fireplace is running, and after it is turned off.

A. The different gauges of steel used to manufacture your fireplace will expand and contract at different rates when your fireplace is on, and will continue as your fireplace completes its heating function. You will likely hear these same sounds more on start up and shut down. This is normal for steel fireplaces.

Q. I hear a “click” when my main burner turns ON or OFF.

A. Your Gas Control Valve will make a clicking sound when it opens to allow gas to flow to the main burner. This is a normal part of the operating system.

Q. Can I burn wood and other materials in my gas fireplace.

A. No! Burning anything other than the fuel (natural gas or propane) the fireplace is setup for will create a potential fire hazard and present a danger to your home and its occupants and possibly void your manufacturer's warranty. Only burn the gas fuel for which the unit was originally designed.

Q. Can I shut my pilot off in the summer?

A. You will save energy by turning off the pilot light if you are not using your appliance for the hot summer months. When in continuous pilot ignition on demand (CPI) mode the pilot will remain lit for seven days after the fireplace is used. When seven days have passed the system will turn the pilot off. When in IPI mode, the pilot will only remain on when the main burner is on.

Q. Why does my fireplace start with a low flame? Shouldn't the flame size match the remote setting?

A. Dynamic Start Advantage was designed to create a draft by starting the fireplace on low and automatically increasing the flame to match the remote setting after two minutes. This system helps to create a better flame appearance, reduce condensation on the glass, and provide years of carefree operation.

Q. Can I position my gas logs in a different fashion or use a different log set?

A. No. Your gas fireplace is an engineered system that includes the firebox, burner, logs, venting and options which are tested and listed with a certification agency. Changing any specifications or placement of the logs could cause injury or damage, void your manufacturer's warranty, and possibly even your homeowner's warranty.

22.0 Replacement Parts List

Item #	Item Description	Unit
200-1127-17	Owner's Manual	EA
200-1127F-16	Owner's Manual (French)	
308-6060	SIT Proflame II Dynamic Start Advantage with Continuous Pilot on Demand	EA
308-6024	SIT Pro Flame II Wall Mountable Remote	EA
308-6017	SIT 885 Gas Valve c/w Step Motor	EA
305-6002	Module Main Wiring Harness (5 wire)	EA
305-6003	Valve Wiring Harness (4 wire)	EA
305-0060	Battery Holder (4-AA)	EA
RP-305-2080	Fuse, 3.15A, 250V (Pack of 5)	EA
301-0068-43	Orifice (Main Burner Orifice) Drill to # 43 DMS for Natural Gas	EA
301-0068-54	Orifice (Main Burner Orifice) Drill to # 54 DMS for LP Gas	EA
308-0124	Pilot Assembly	EA
308-0125	PSE Spark Igniter	EA
308-0126	PSE Flame Sensor	EA
827-1050	Burner Assembly	EA
733-0027	Pilot Shield	EA
27-CKELP	Conversion Kit NG to LP	EA
27-CKENG	Conversion Kit LP to NG	EA
RF-305-0024	Replacement Cross-flow Fan (120VAC, 115V, 24 watt)	EA
310-6270	Log Set	
827-0000	Complete Replacement Door Black. Includes glass, gasket and door frame	EA
27-BS	Barrier Screen	EA

Archgard Limited Warranty

This Limited Warranty is made by ARCHGARD INDUSTRIES LTD., hereinafter referred to as "Archgard". Archgard warrants to the original purchaser of an Archgard gas burning fireplace(s) that the product will be free from defects in materials and workmanship under normal use and service, for a "lifetime". All warranty repairs are to be performed by an authorized Archgard Dealer during the warranty period. Other repair / service company charges for any work done during the warranty period, will be the responsibility of the home owner.

INCLUSIONS: "LIFETIME LIMITED WARRANTY"

- All heat exchangers and combustion chamber
- Ceramic Fiber Logs and Ceramic Brick Panels, against splitting and cracking due to heat exposure

NOTE: Discoloration and some minor movement including warping of certain parts are normal and are not a defect; therefore, not covered under warranty.

INCLUSIONS: "SEVEN YEAR LIMITED WARRANTY"

- Burner tubes and pans

INCLUSIONS: "TWO YEAR LIMITED WARRANTY"

- Ceramic Glass against thermal breakage
- Trims and accessories from splitting or separating
- Electronic Control Module, Remote Transmitter

Items included with ten-year and two-year limited warranty will be covered under "Parts & Subsidized Labour" to the original purchaser for one (1) year and "Parts Only" thereafter from original date of purchase.

INCLUSIONS: "ONE YEAR LIMITED WARRANTY"

- Blowers, fans and fan motors, wiring, rheostats and thermodiscs
- Rocker switches, spill switches and wiring to them
- Gas control valves, pilot assemblies including thermopiles, thermocouples, electrodes and igniters
- Paint peeling or cracking

Items included in the one-year limited warranty will be covered under "Parts & Subsidized Labour" to the original purchaser for one (1) year from date of purchase.

WHAT TO DO IN THE EVENT OF A PROBLEM:

- Thoroughly read your "Owner's Installation, Operation & Maintenance Manual"
- If you cannot solve the problem, contact your Archgard dealer or representative
- When calling for assistance, please have the following information:

Model of your fireplace Serial Number Place of Purchase
Date of Purchase Problem Description

NOTE: Warranty will be void if work is carried out by an unqualified person(s). Only original Archgard parts may be used. Please consult your Archgard dealer or representative if in doubt about a replacement part(s).

- All warranty repairs are to be performed by an authorized Archgard Dealer during the warranty period. Other repair / service company charges for any work done during the warranty period, will be the responsibility of the home owner.

OBTAINING WARRANTY SERVICE:

The original purchaser shall return the defective part(s) to the original authorized Archgard dealer – transaction prepaid, along with the serial number of the appliance and original proof of purchase. Any defective part, in our judgment, will be repaired or replaced at Archgard's discretion. The dealer must obtain approval from Archgard before any repairs are made.

WARRANTY LIMITATION:

THIS LIMITED WARRANTY IS MADE IN LIEU OF ALL OTHER WARRANTIES, EXPRESSED OR IMPLIED AS TO QUALITY, MERCHANTABILITY OR FITNESS FOR PARTICULAR PURPOSE.

The appliance is only warranted for the use as intended by the installation and operating instructions and local building codes. The warranty will not cover damage due to accident, misuse, abuse, alteration, improper installation or "Acts of God". This limited warranty is void unless the appliance is installed by a qualified Archgard installer, in accordance with the instructions furnished with the appliance. Some Provinces or States do not allow limitations on how long an implied warranty lasts, so the above limitations may not apply to the original purchaser. Any damage resulting from defects in this product is limited to the replacement of the defective part(s) and does not include incidental and consequential exposures sustained in connection with the product. This includes facing(s), mantle(s), cabinet(s), tile(s) or any other finishes resulting from removal of any gas appliance. This warranty is limited to residential use only and gives the consumer specific rights. These rights may vary from State to State or Province to Province.

WARRANTY CONDITIONS & REQUIREMENTS:

1. You are the original purchaser – this warranty is not transferable.
2. Installation of the fireplace must be performed by a qualified Archgard installer.
3. Installation and operation must comply with the installation and operation instructions.
4. All optional accessories are covered for one (1) year from the date of purchase.
5. This warranty does not offer coverage for light bulbs or batteries (whether factory, dealer, or installer supplied). This includes any damage stemming from non-use.
6. Damage during shipping or handling of components, defects resulting from improper installation or service, or misuse of the fireplace or fireplace components are not covered under this warranty.
7. This warranty does not cover any part of the fireplace or any component which has been exposed to or submerged under water.
8. Archgard must be notified by the dealer the fireplace was purchased from or a qualified Archgard technician of the defect.
9. Annual service of the fireplace as required in the installation manual must be performed by a qualified Archgard technician (service records may be required to claim a warranty).
10. All previous warranty service must have been performed by a qualified Archgard technician (service records may be required to claim a warranty).
11. Travel time or mileage to the original purchaser's residences is not covered under this warranty. We suggest that you pre-arrange travel expenses with your Authorized Archgard Dealer.
12. Freight on warranty shall be covered for the first two years of the warranty period.

POSTAGE

WARRANTY REGISTRATION

ARCHGARD INDUSTRIES LTD.
PO BOX 318
RAYMOND, AB
T0K 2S0

CUT ALONG LINE

FOLD DOWN AT LINE

CUT ALONG LINE

FOLD DOWN AT LINE & TAPE CLOSED

Model # : _____ Serial #: _____ Date Installed: _____ / _____ / _____

Name: _____ Address: _____

City: _____ State/Prov: _____ ZIP: _____ Phone: (_____) _____

Dealer's Name & Address: _____

City: _____ State/Prov: _____ ZIP: _____ Phone: (_____) _____

Installer's Name & Address: _____

City: _____ State/Prov: _____ ZIP: _____ Phone: (_____) _____

Why did you choose this product? _____

CUT ALONG LINE

Thank you for purchasing our product and filling out this warranty card. Save time by completing this form at www.archgard.com/warranty-registration

ARCHGARD INDUSTRIES LTD.

300 RAILWAY AVENUE
RAYMOND, AB T0K 2S0
CANADA

WWW.ARCHGARD.COM